

ROGUE® PRO-S

Assembly Guide
Guide d'assemblage
Guía de ensamblaje



↑
Upgrade your
experience.
Améliorez votre
expérience.
Mejora tu
experiencia.



Models | Modèles | Modelos

RPS425RSIB-2 | RPS425-PHM | RPS525RSIB-2

RPS625RSIB-2



Assembly Guidelines | Guide de montage | Guía de instalación

Safety requirements
Exigences de sécurité
Requerimientos de seguridad



Tools requirements for installation (not included)
Outils nécessaires à l'installation (non inclus)
Herramientas necesarias para la instalación (no incluidas)



3/8
(10 mm)

3/8
(10 mm)

Legend | Légende | Leyenda



Warning!
Avertissement !
¡Advertencia!



Caution!
Attention !
¡Precaución!



Lock
Sécurisé
Asegure



Positioning
Positionnement
Posicionamiento



Strike with a rubber mallet
Frapper avec un marteau en caoutchouc
Golpear con un mazo de goma



Propane Only
Propane uniquement
Sólo propano



Natural Gas Only
Gaz naturel uniquement
Sólo gas natural



Remove protective film.
Retirer le film protecteur.
Retire la película protectora.



Rotate the Unit
Rotation de l'appareil
Rotar la unidad



Magnetic material
Matériau magnétique
Material imantado



Caution! Head Injury
Attention! Blessure à la tête
Precaución! Lesión en la cabeza

WELCOME TO NAPOLEON!

Congratulations on upgrading your grilling game and welcome to the **NAPOLEON** family!



Ready to assemble your new grill?



There may be visual differences between illustrations and model purchased. Remove all parts from packaging before assembling the barbecue. Set up this assembly on a solid, level and horizontal surface.



Register your grill today.

We're here to accompany you through unforgettable moments.

BIENVENUE À NAPOLEON!

Félicitations pour votre achat et bienvenue dans la famille **NAPOLEON!**



Prêt à assembler votre nouveau grill?



Veillez noter qu'il peut y avoir des différences entre les illustrations de ce guide et le modèle acheté. Retirez toutes les pièces de leur emballage avant de commencer. Veillez à assembler votre grill sur une surface plane et solide.



Inscrivez votre grill dès aujourd'hui.

Nous sommes là pour vous accompagner dans des moments inoubliables.

¡BIENVENIDO A NAPOLEON!

¡Felicidades por mejorar tu juego de parrilla y bienvenido a la familia **NAPOLEON!**



¿Listo para ensamblar tu nueva parrilla?



Tenga en consideración que puede haber diferencias entre las ilustraciones en esta guía y el modelo adquirido. Remueva todas las piezas de sus empaques antes de comenzar. Asegúrese de ensamblar la parrilla en una superficie plana y sólida.



Registra hoy mismo tu parrilla.

Estamos aquí para acompañarte en momentos inolvidables.

Models | Modèles | Modelos

RPS425RSIB-2

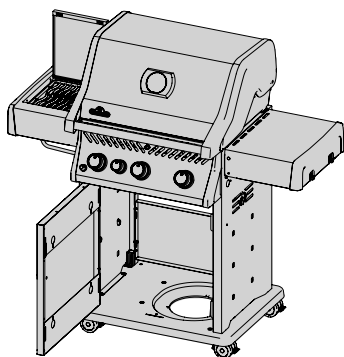

RPS425-PHM

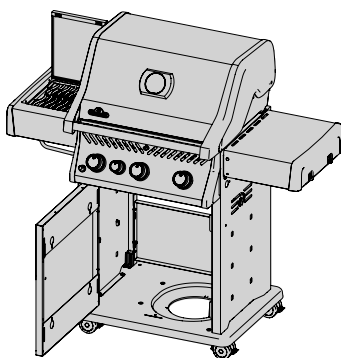

RPS525RSIB-2

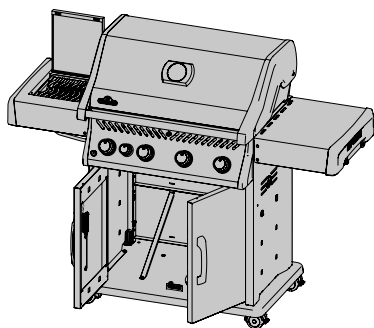

RPS625RSIB-2

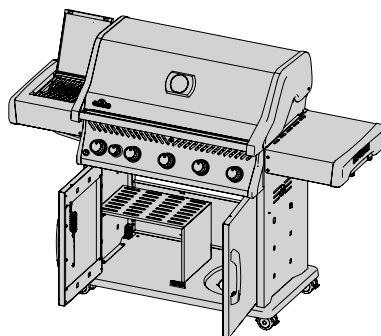

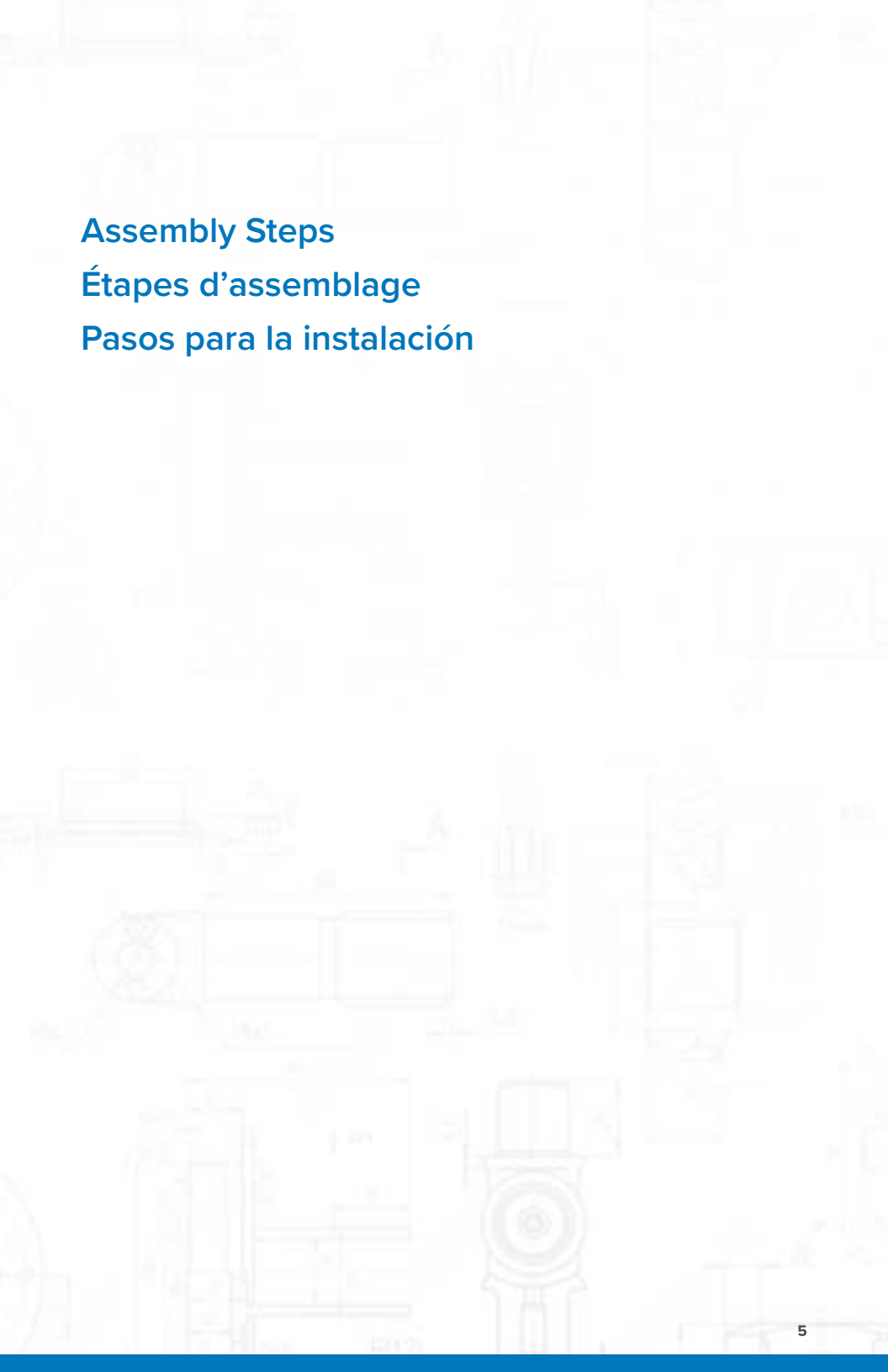

Assembly Steps
Étapes d'assemblage
Pasos para la instalación

1

 x4

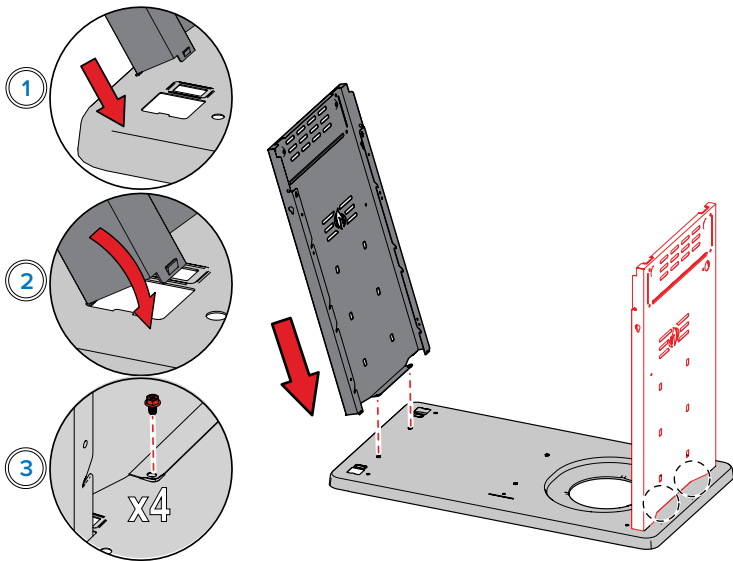

2

 x8  x2

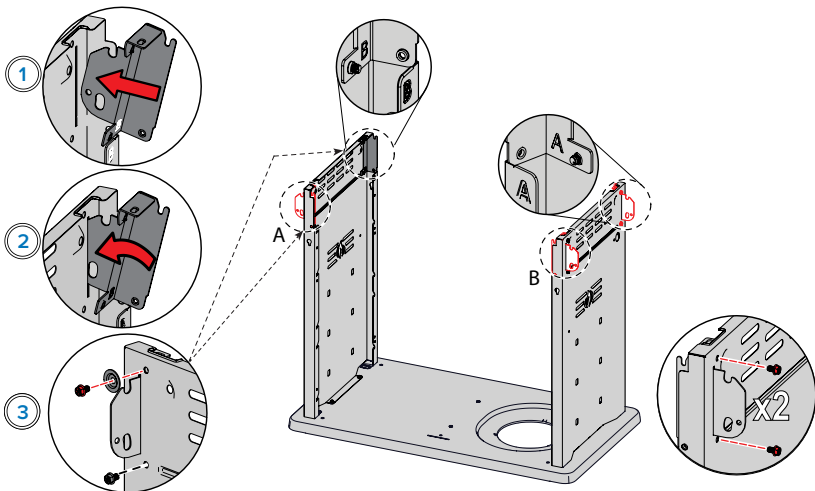

3

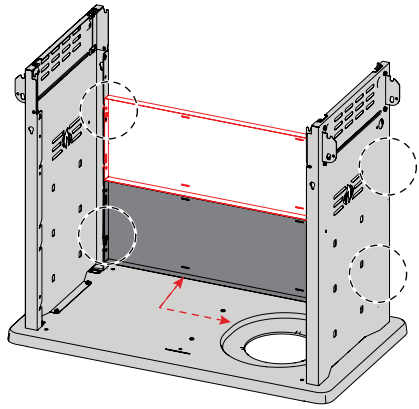
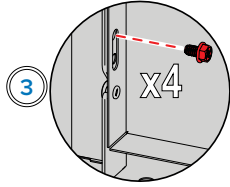
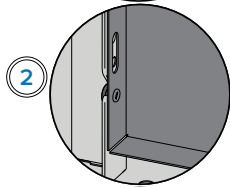
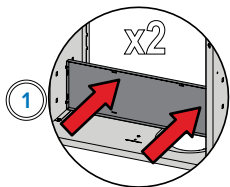

4

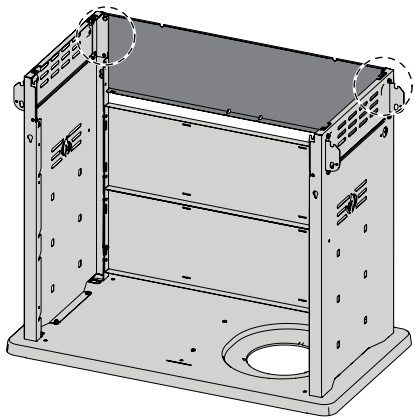
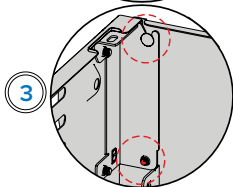
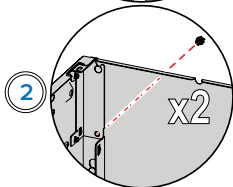
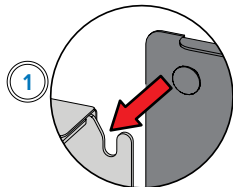

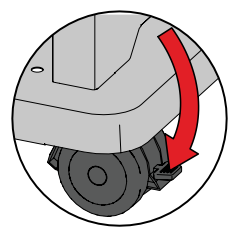
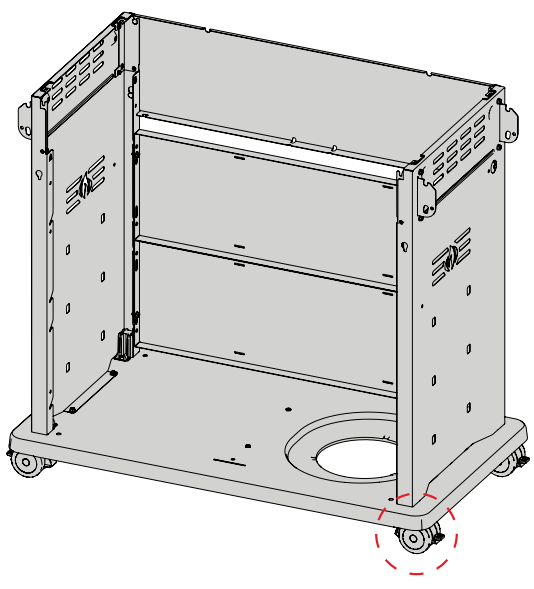
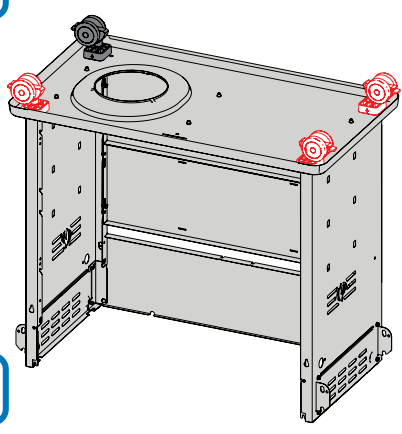
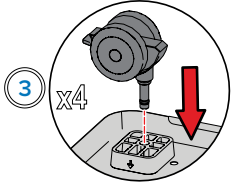
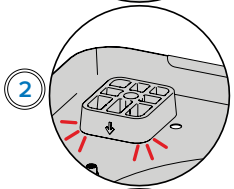
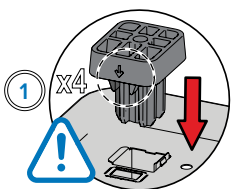

6

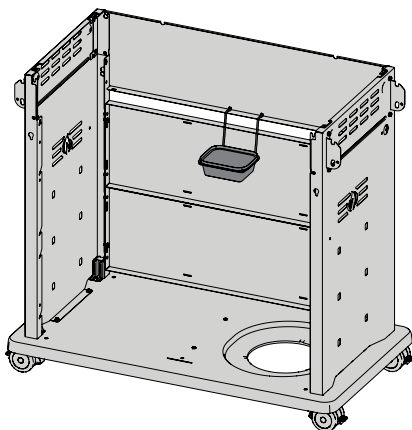
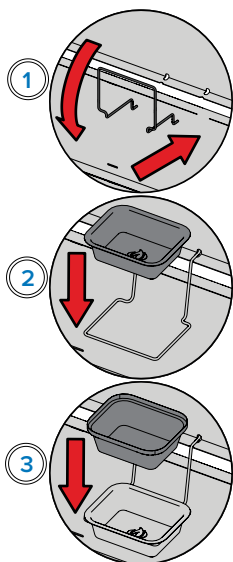

7

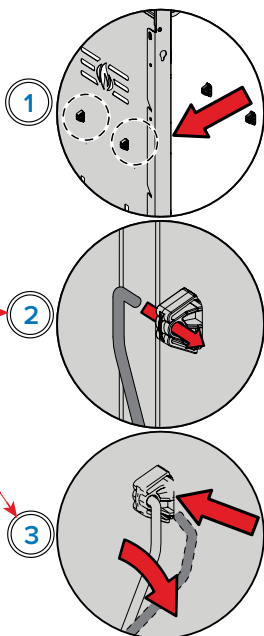
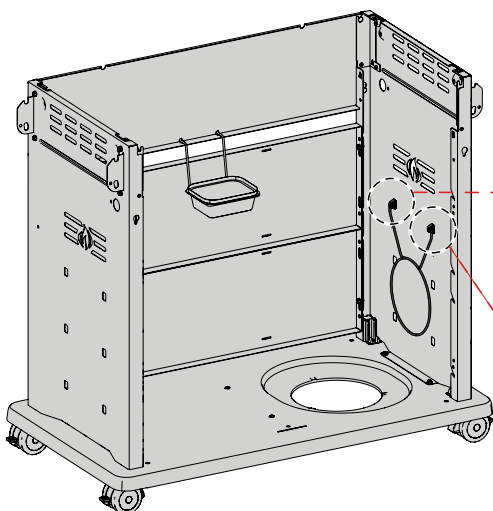

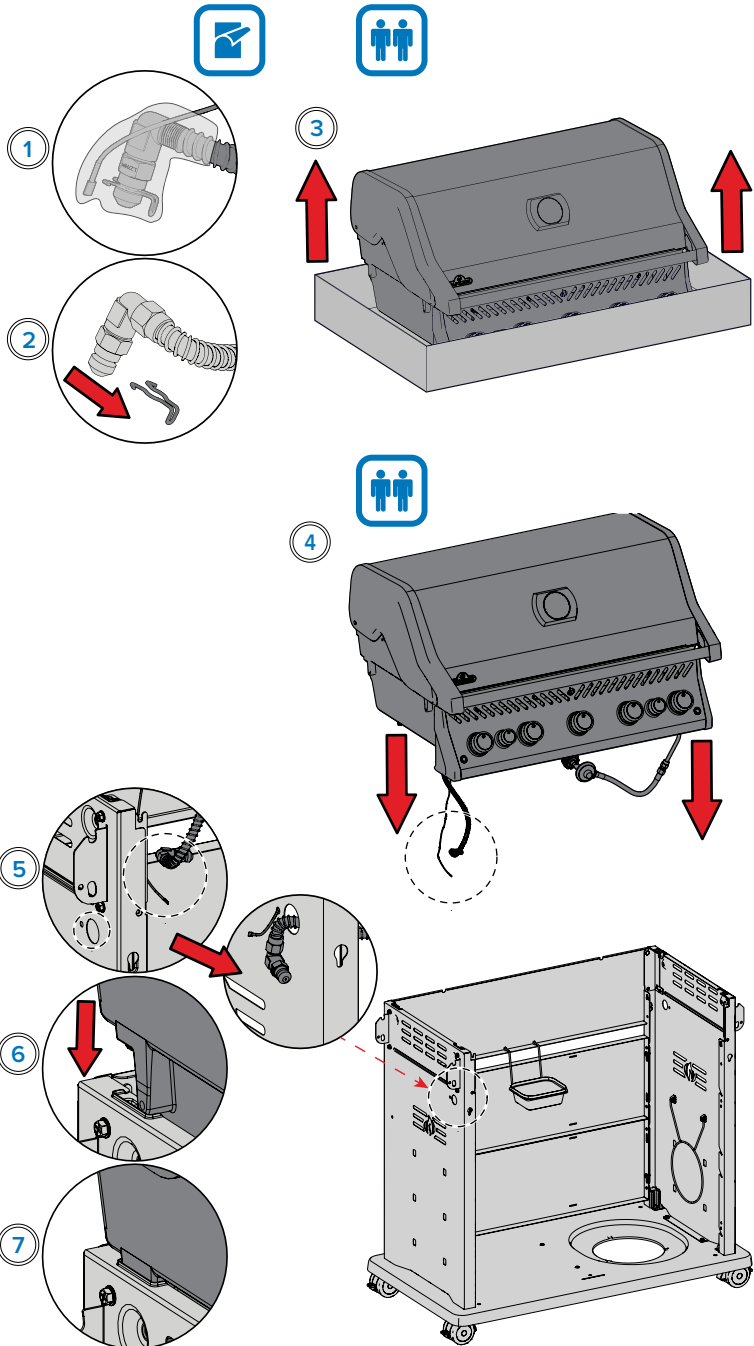

9

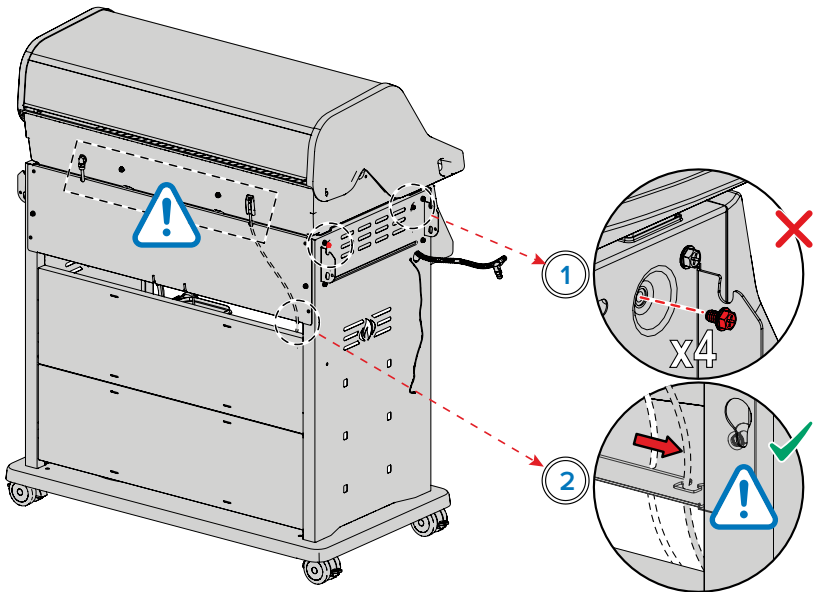

10

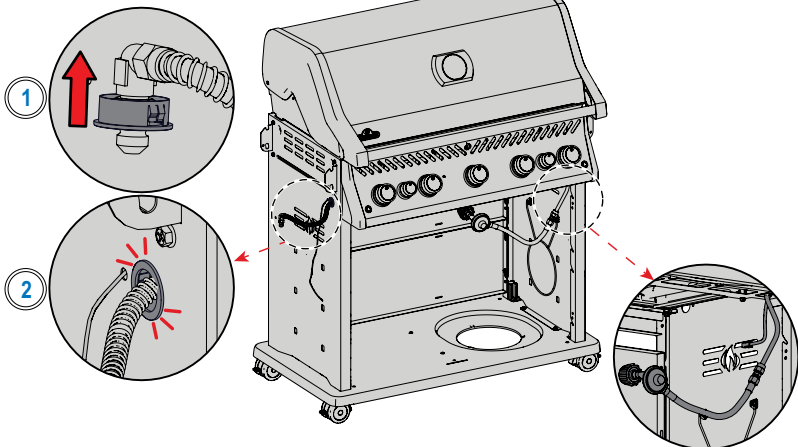

11

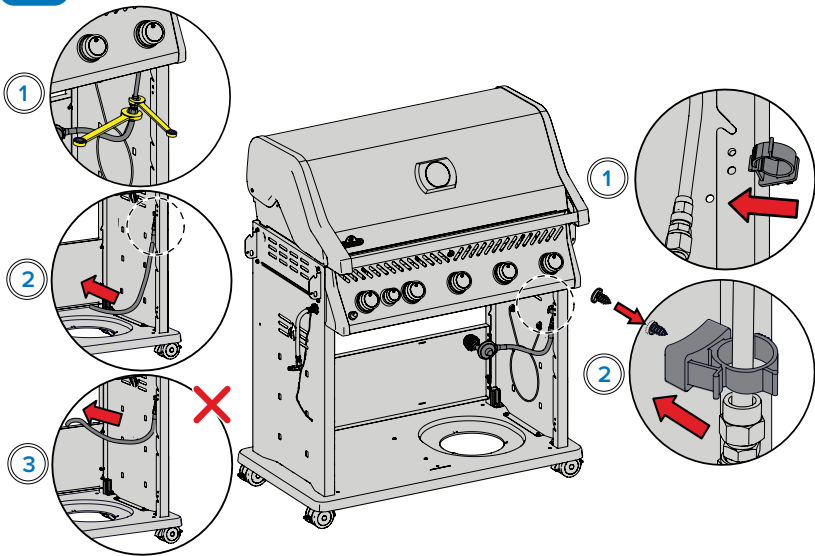

12

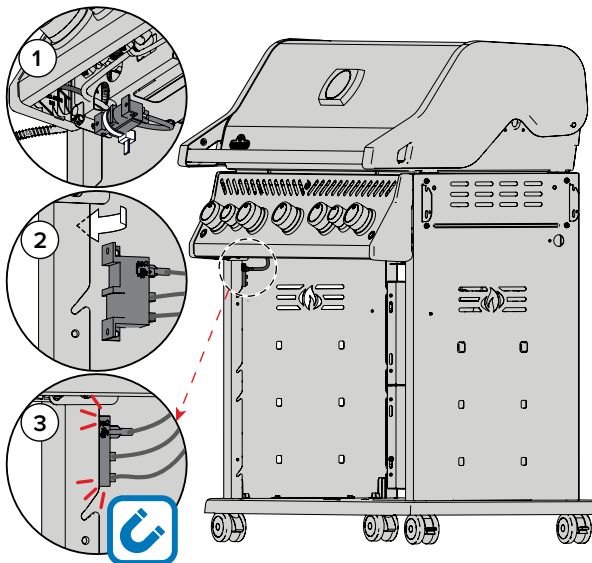

 x2 (625)

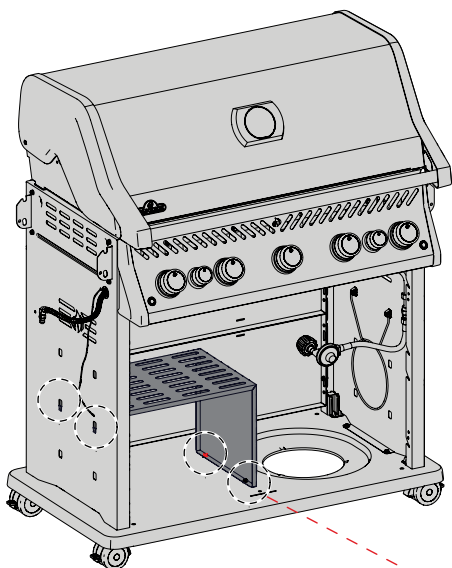

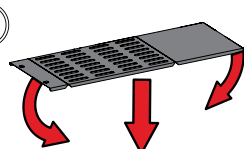
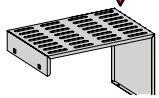
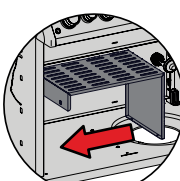
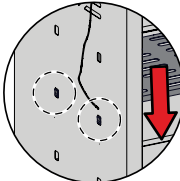
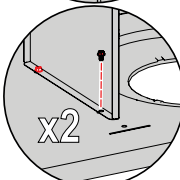
- 1 
- 2 
- 3 
- 4 
- 5  x2

 x1 (525)

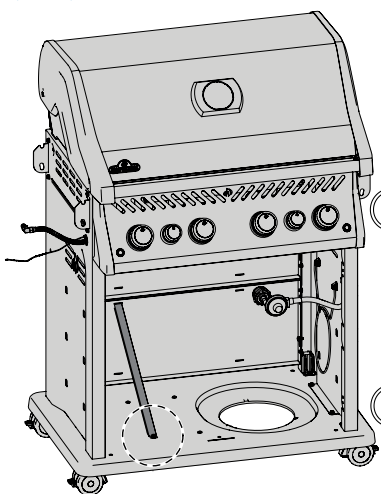

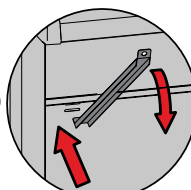
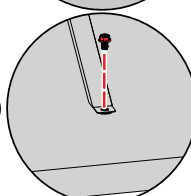
- 1 
- 2 



x1 (625 / 525)

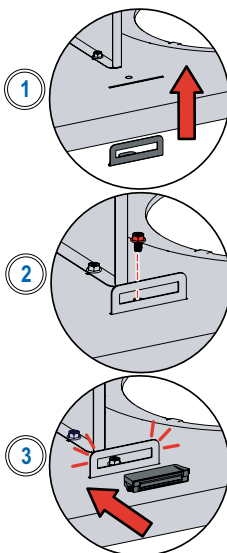
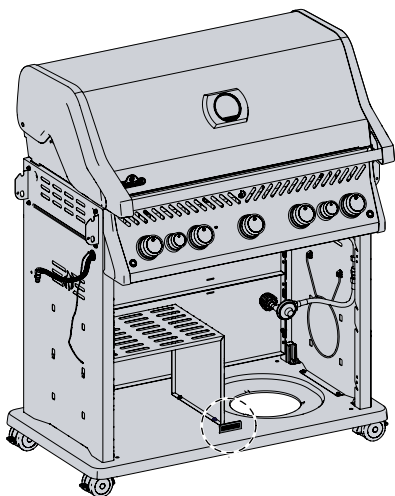

x2 (425)

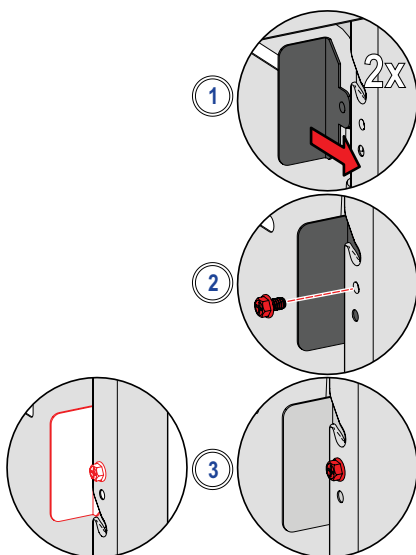
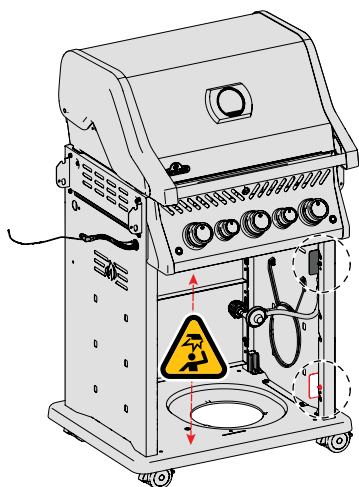

15



x2 (625 / 525)



x1 (425)

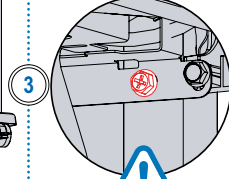
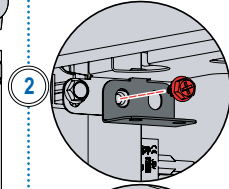
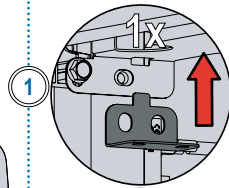
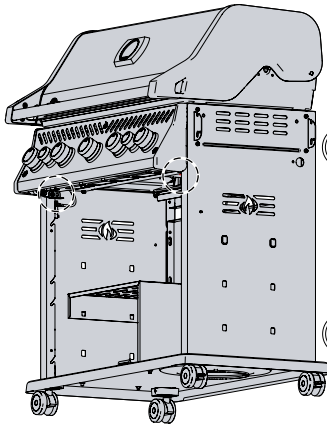
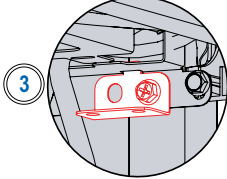
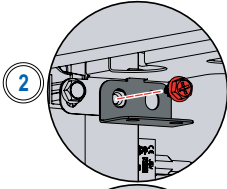
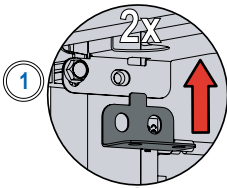

16



525/625



425

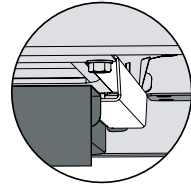
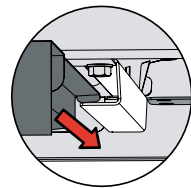
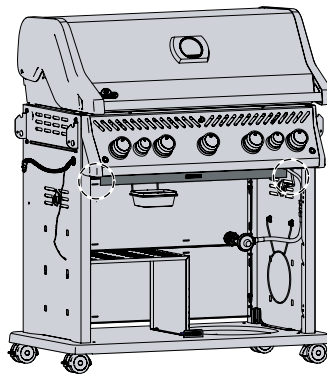
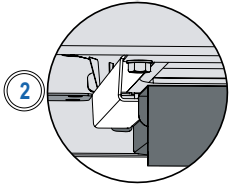
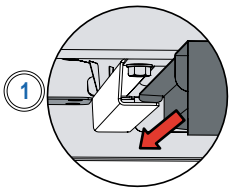
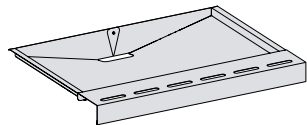
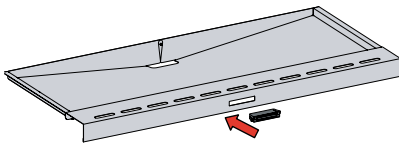

17

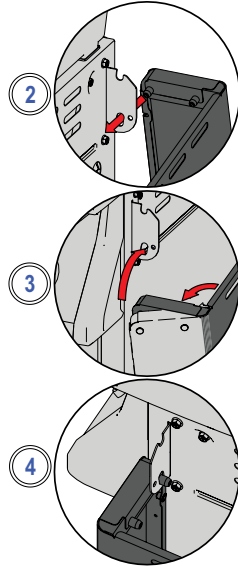
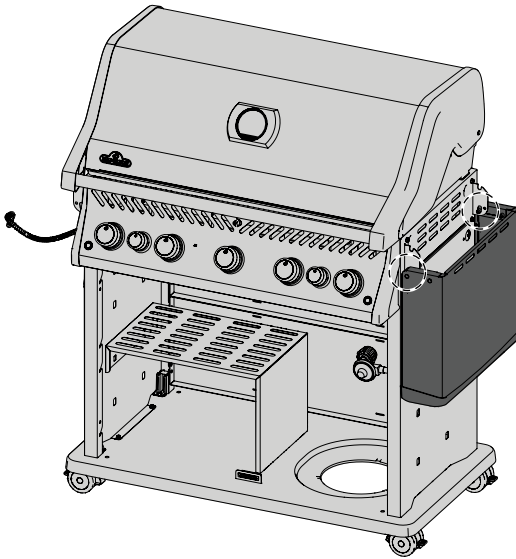

18

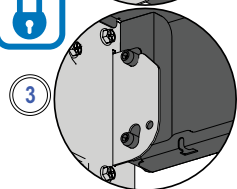
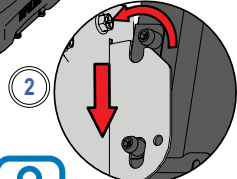
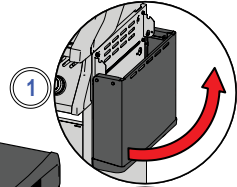
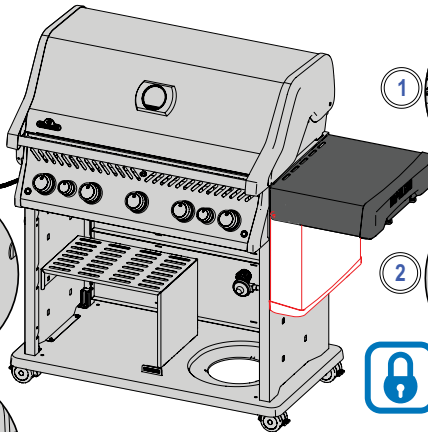
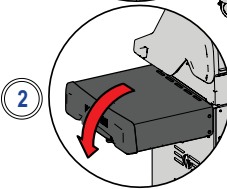
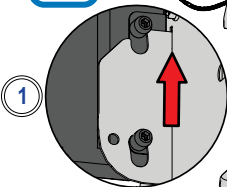

19

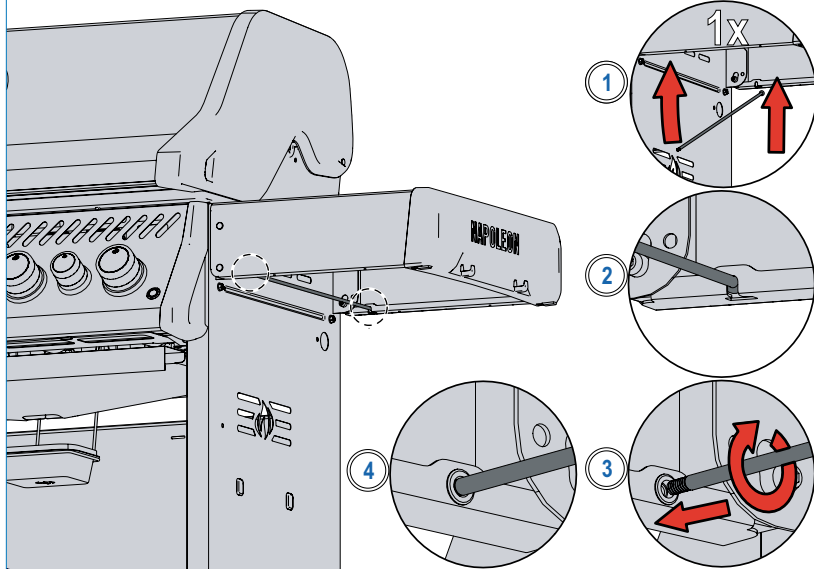

20

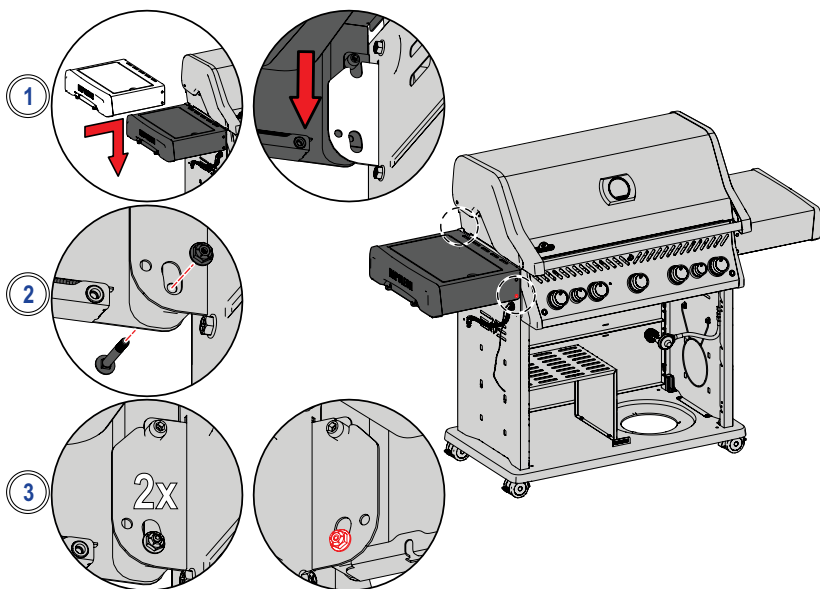

21

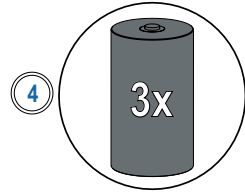
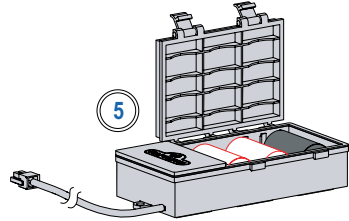
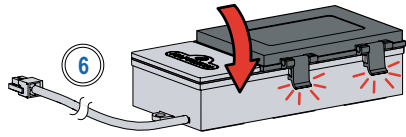
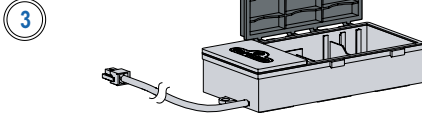
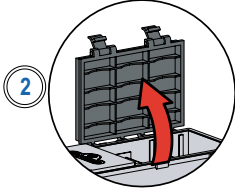
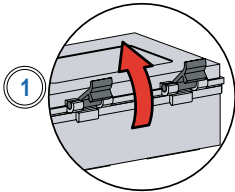

22

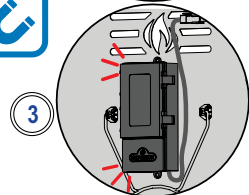
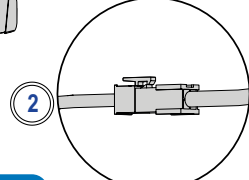
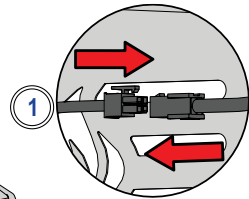
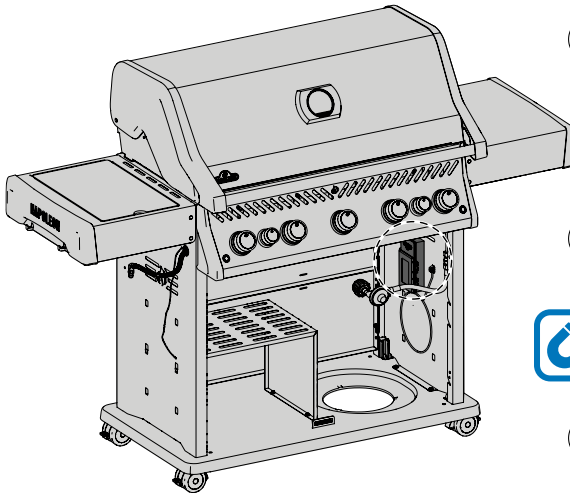

23



x4 (625 / 525)



x2 (425)

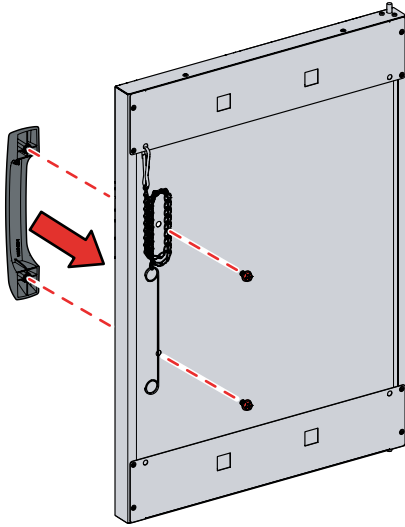

24



x2 (625 / 525)



x1 (425)

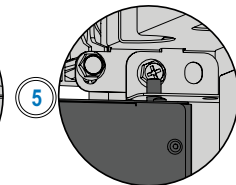
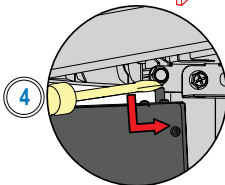
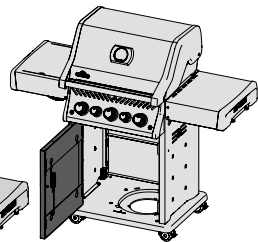
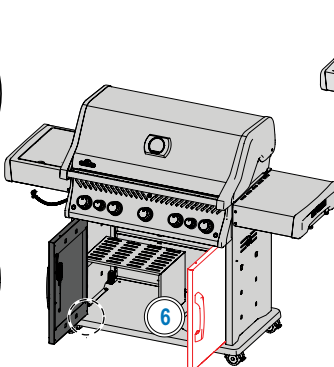
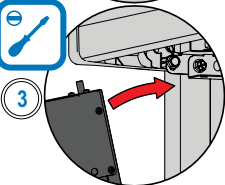
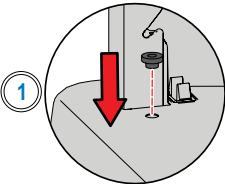

25

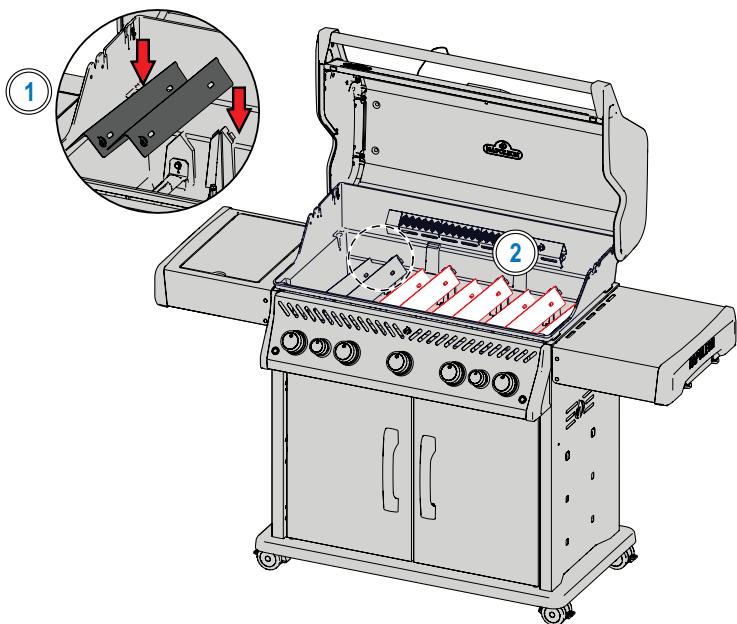

26

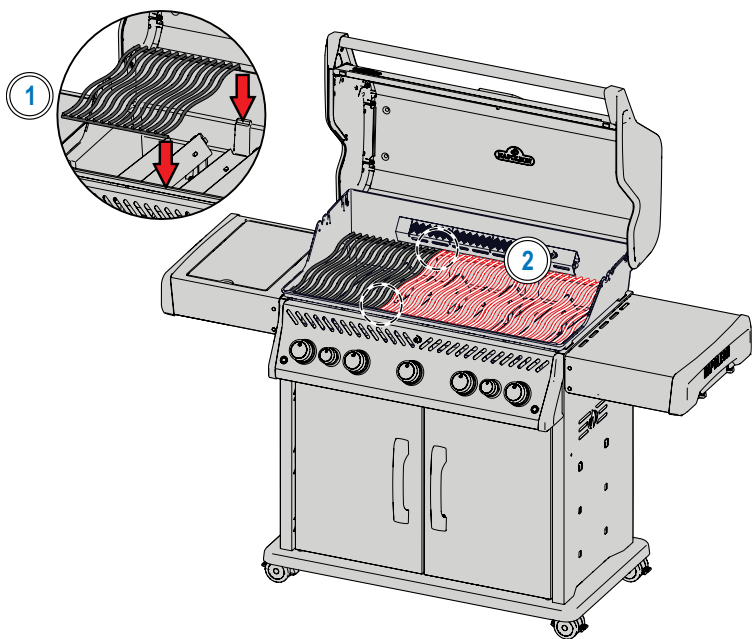

27

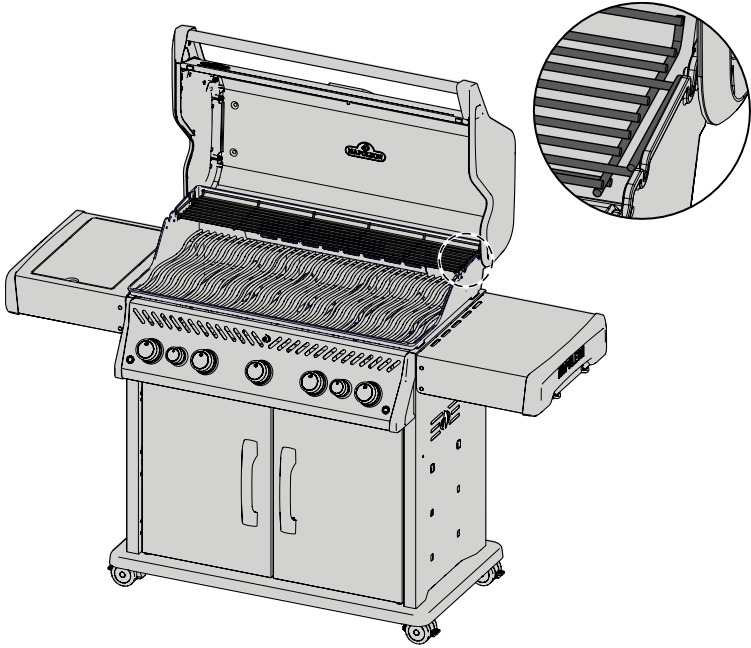

28

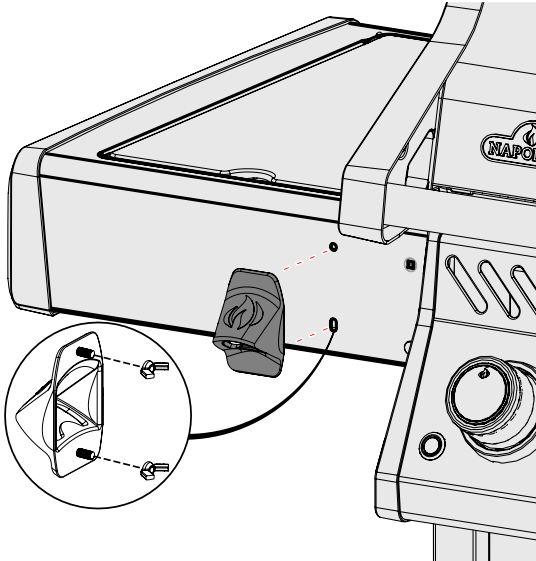

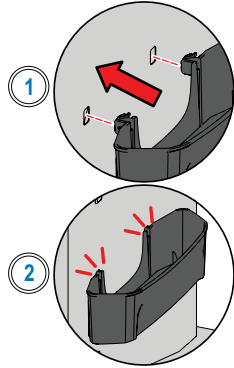
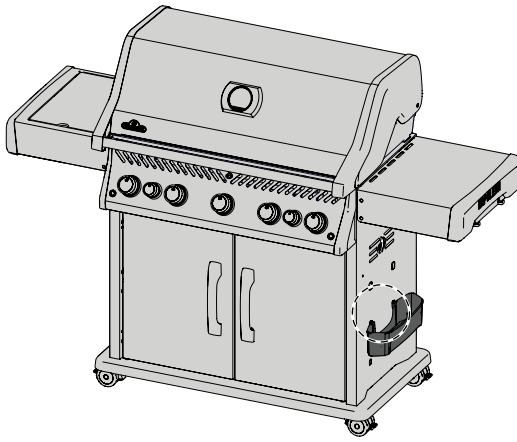

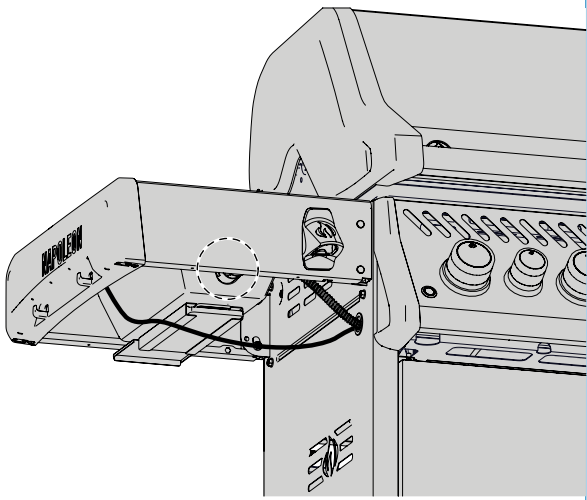
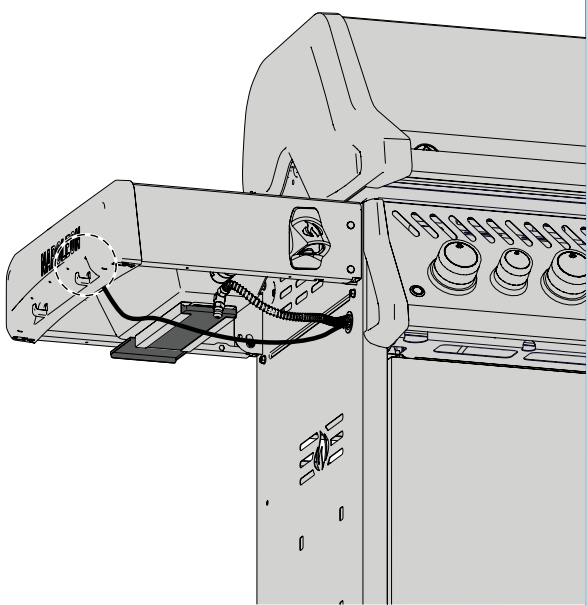
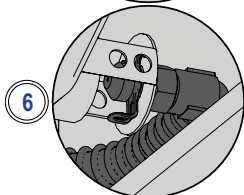
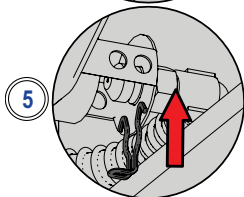
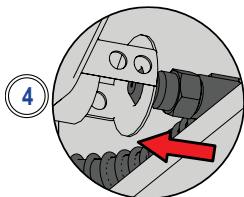
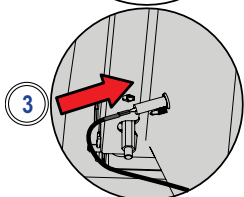
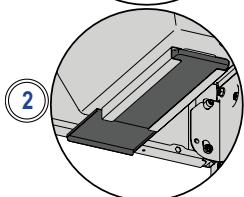
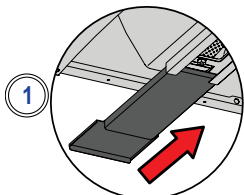

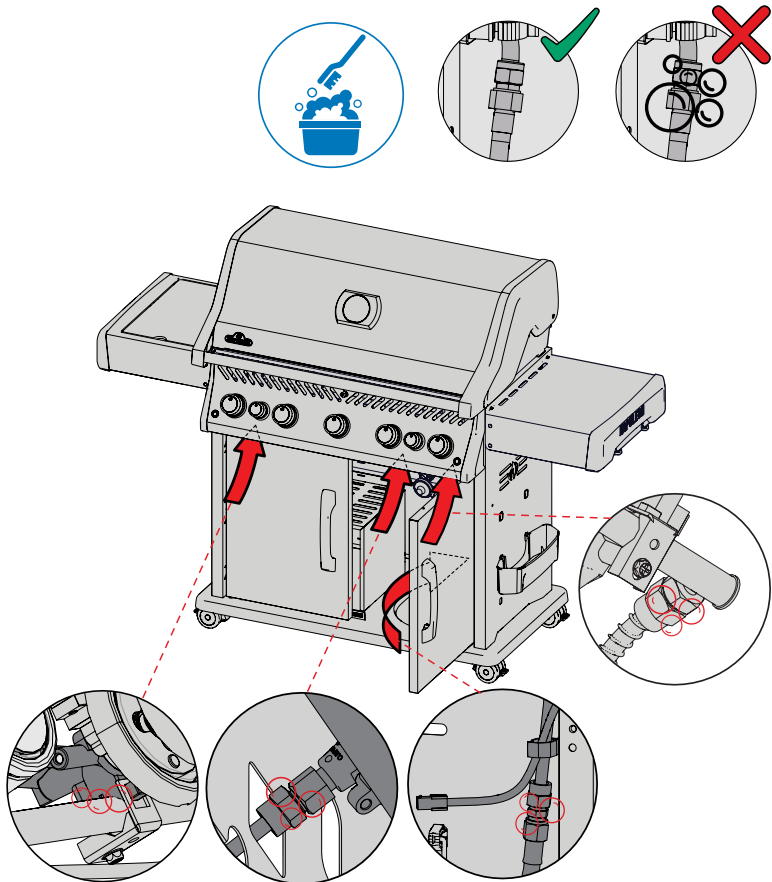

Parts List

Liste des pieces

Lista de piezas

Parts Lists | Liste des pieces | Lista de piezas

Legend

x - standard part
p - propane
n - natural
ac - accessory

Légende

x - standard
p - propane
n - gas naturel
ac - accessoire

Leyenda

x - estándar
p - propano
n - gas natural
ac - accesorio

	Part # Partie # Parte #	RPS425R SIB-2	RPS425 PHM	RPS525R SIB-2	RPS625 RSIB-2	Description Description Descripción
1	N010-1754-SS	x				Lid Assembly Assemblage du couvercle Set de ensamblado de la tapa
	N010-1754-MK		x			
	N010-1755-SS			x		
	N010-1756-SS				x	
2	S91015	x	x	x	x	Temperature Gauge Jauge de température Indicador de temperatura
3	N385-0513-SER	x	x	x	x	Napoleon Logo Logo Napoléon Logo Napoleón
4	N510-0013	x	x	x	x	Rectangular Bumper Pare-chocs rectangulaire Parachoques rectangular
5	S87014	x	x	x	x	Pivot Lid Couvercle pivotant Tapa pivotante
6	N010-1149-SER	x	x			Base Casting Assembly Assemblage de la base de coulée Conjunto de fundición base
	N010-1150-SER			x		
	N010-1235-SER				x	
7	N240-0040	x	x	x	x	Electrode Électrode Electrodo
8	N570-0104	x	x	x	x	Screw Vis Tornillo
9	N350-0087	x	x	x	x	Rear Burner Housing Boîtier du brûleur arrière Carcasa del quemador trasero
10	N100-0058	x	x	x	x	Rear Burner Brûleur arrière Quemador trasero
11	N720-0082	x	x	x	x	Flex Connector Connecteur flexible Conector flexible
12	N455-0099	p	p	p	p	Rear Orifice Orifice arrière Orificio trasero
	N455-0100	n	n	n	n	
13	N100-0060	x	x	x	x	Main Tube Burner Brûleur du tube principal Quemador de tubo principal
14	N305-0108	x	x	x	x	Sear Plate Plaque de saisie Plato para saltear

	Part # Partie # Parte #	RPS425R SIB-2	RPS425 PHM	RPS525R SIB-2	RPS625 RSIB-2	Description Description Descripción
15	S87010	x	x			Cross Light Bracket Support d'éclairage transversal Soporte de luz transversal
	S87013			x		
	S87017				x	
16	S87001	x	x	x	x	Sear Burner Kit Kit brûleur de cuisson Kit quemador para dorar
17	N520-0055	x	x			Warming Rack Support de réchauffage Rejilla de calentamiento
	N520-10001898			x		
	N520-10001899				x	
18	S83013	x	x			Stainless Steel Grids Grilles en acier inoxydable Rejillas de acero inoxidable
	S83023			x		
	S83022				x	
	S83008	ac	ac			Cast Iron Grids Grilles en fonte Rejillas de hierro fundido
	S83024			ac		
	S83021				ac	
19	N200-0118-GY1SG	x				Base Back Cover Couvercle arrière de la base Tapa trasera de la base
	N200-0118-BK1TX		x			
	N200-0127-GY1SG			x		
	N200-0135-GY1SG				x	
20	N160-0033-GY1SG	x	x	x	x	Grease Tray Clip Clip pour bac à graisse Clip para bandeja de grasa
21	N710-0062	x	x	x	x	Grease Tray Bac à graisse Bandeja de grasa
	62007	ac	ac	ac	ac	
22	N475-0363-GY1SG (x2)	x				Rear Cart Panel Panneau arrière du chariot Panel trasero del carro
	N475-0363-BK1TX (x2)		x			
	N475-0449-GY1SG (x2)			x		
	N475-0499-GY1SG (x2)				x	
23	N590-0261	x	x	x	x	Condiment Tray Plateau à condiments Bandeja de condimentos
24	N080-0364	x	x	x	x	Folding Shelf Bracket Support d'étagère pliante Soporte de estante plegable
25	N350-0077LY	x	x	x	x	Battery Housing Boîtier de batterie Alojamiento de la batería

	Part # Partie # Parte #	RPS425R SIB-2	RPS425 PHM	RPS525R SIB-2	RPS625 RSIB-2	Description Description Descripción
26	N710-0094	x	x			Drip Pan Bac d'égouttage Bandeja de goteo
	N710-0108			x		
	N710-0120				x	
27	N080-0378-GY1SG	x	x	x	x	Pivot Door Bracket Support de porte pivotante Soporte de puerta pivotante
28	N430-0002			x	x	Magnetic Catch Loquet magnétique Cierre magnético
29	N080-0365	x	x	x	x	Folding Shelf Bracket Support d'étagère pliante Soporte de repisa plegable
30	N750-0016	x	x	x	x	Wire Fil Cable
31	N357-0021LY	x	x	x	x	Igniter Allumeur Encendedor
32	N455-0109	p	p	p	p	Orifice Orifical Orificio
	N455-0110	n	n	n	n	
33	N160-0023	x	x	x	x	Orifice Retainer Clip Clip de retenue d'orifice Clip de retención del orificio
34	N080-0380-GY1SG	x	x			Magnet Bracket Support magnétique Soporte Imán
35	N010-1357	x	x	x	x	Flex Hose Assembly Ensemble de tuyau flexible Conjunto de manguera flexible
36	W105-0010	x	x	x	x	Bushing Bague Amortiguador
37	N080-0387-GY1SG			x	x	Magnet Bracket Support magnétique Soporte Imán
38	N570-0118			x	x	Screw Vis Tornillo
39	S82001	x	x	x	x	Caster Roue dentée Rueda
40	N510-0015	x	x	x	x	Caster Socket Socle de roulette Zócalo de ruedas
41	N590-0256-GY1SG	x				Cart Bottom Shelf Tablette inférieure du chariot Estante inferior del carro
	N590-0256-BK1TX		x			
	N590-0281-GY1SG			x		
	N590-0323-GY1SG				x	
42	N475-0607-GY1SG	x		x	x	Panel Panneau Panel
	N475-0607-BK1TX		x			
43	S85001	p	p	p		Hose Regulator Régulateur de tuyau Regulador de manguera
	N530-0057				p	
	S85002	n	n	n	n	

	Part # Partie # Parte #	RPS425R SIB-2	RPS425 PHM	RPS525R SIB-2	RPS625 RSIB-2	Description Description Descripción
44	N255-0027	x	x	x	x	Union Fitting Raccord union Accesorio de unión
45	N160-0035	p	p	p	p	Retainer Tank Clip Clip de maintien du réservoir Clip de retención del depósito
46	N160-0034-GY1SG	p	p	p	p	Top Retainer Tank Clip Clip de maintien supérieur du réservoir Clip de retención superior del depósito
47	N010-0869-SS-SER	x				Single Door Assembly Assemblage de porte simple Conjunto de puerta simple
	N010-0869-BX-SER		x			
	N010-0984-SS-SER			x		
	N010-1221-SS-SER				x	
48	N010-1782-SS	x	N010- 1782-MK	x	x	Rogue Shelf Assembly Assemblage d'étagères Rogue Kit de estante Rogue
49	N385-10001898	x		x	x	Rogue Logo Logo Rogue Logotipo Rogue
	N385-10001898-BK		x			
50	N370-0928-SER	x	x	x	x	Shelf Kit Kit d'étagères Kit de estantes
51	N555-0097	x	x	x	x	Lighting Match Rod Tige d'allumage Varilla de fósforo
52	N325-0094-SER	x		x	x	Door Handle Poignée de porte Manija de la puerta
	N325-0094-BK0TX-SER		x			
53	N105-0011	x	x	x	x	Door Pivot Bushing Douille de pivot de porte Casquillo pivote de puerta
54	N010-1781-SS	x	N010- 1781-MK	x	x	Rogue Shelf Assembly Assemblage du plateau Rogue Ensamblaje de la estantería Rogue
55	N335-0098-M06	x	N335- 0098- BK1HR	x	x	Lid Couvercle Tapa
56	N305-10001280	x	x	x	x	Wavy Grid Grille ondulée Parrilla onculada
57	S81005	x	x	x	x	Side Burner Brûleur latéral Quemador lateral
58	N500-0039K	x	x	x	x	Plate Assiètte Placa
59	N240-0026	x	x	x	x	Electrode Électrode Electrodo
60	N510-0013	x	x	x	x	Rectangular Bumper Pare-chocs rectangulaire Tope rectangular

	Part # Partie # Parte #	RPS425R SIB-2	RPS425 PHM	RPS525R SIB-2	RPS625 RSIB-2	Description Description Descripción
61	N080-0358	x	x	x	x	Drip Pan Bac d'égouttage Bandeja de goteo
62	N710-0063	x	x	x	x	Drip Pan Bac d'égouttage Bandeja de goteo
63	N510-0002	x	x	x	x	Bumper Pare-chocs Tope
64	N570-0128	x	x	x	x	Screw Vis Tornillo
65	N450-0053	x	x	x	x	Nut Écrou Tuerca
66	N450-0049	x	x	x	x	Nut Post Postes d'écrous Poste de tuerca
67	N555-0091	x	x	x	x	Pivot Rod Tige pivotante Varilla pivotante
68	N485-0021	x	x	x	x	Pin Épingle Clavija
69	N080-0422-SER	x	x	x	x	Bottle Opener Ouvre-bouteille Abrebotellas
70	N010-1775-LP-SS	p				Control Panel Assembly Assemblage du panneau de contrôle Emsablaje del panel de control
	N010-1775-NG-SS	n				
	N010-1775-LP-MK		p			
	N010-1775-NG-MK		n			
	N010-1776-LP-SS			p		
	N010-1776-NG-SS			n		
	N010-1777-LP-SS				p	
	N010-1777-NG-SS				n	
71	N010-10001935	x	x			Wire Harness Assemblage du faisceau de câbles Mazo de cables
	N010-1052LY			x		
	N010-1104LY				x	
72	N720-0044	x	x	x	x	Connector Connecteur Conector
73	N160-0053	x	x	x	x	Flex Line Clip Clip pour ligne flexible Clip de línea flexible
74	N660-0008LY	x	x	x	x	Switch Interrupteur Interruptor
75	N380-0040	x	x	x	x	Knob Bouton Perilla
76	N010-1054LY	x	x	x	x	LED Light Bezel Assembly Assemblage de la lunette d'éclairage LED Conjunto de bisel de luz LED
77	N380-0039	x	x	x	x	Control Knob Bouton de commande Mando de control

	Part # Partie # Parte #	RPS425R SIB-2	RPS425 PHM	RPS525R SIB-2	RPS625 RSIB-2	Description Description Descripción
78	N010-1053LY	x	x	x	x	LED Light Bezel Assembly Assemblage de la lunette d'éclairage LED Conjunto de bisel de luz LED
79	N080-0254G			p		Tank Inhibitor Bracket Support d'inhibiteur de réservoir Estante Inhibidor de depósito
80	N590-0327-GY1SG				x	Storage Shelf Étagère de rangement Estante de almacenamiento

Accessories Parts List
 Liste des pièces accessoires
 Lista de piezas de accesorios

Part # Partie # Parte #	RPS425	RPS525	RPS625	Description Description Descripción
62050	ac	ac	ac	Kit, Maintenance Jetfire Brush/Burner Kit Kit de maintenance Jetfire (brosse/burner kit) Kit, Mantenimiento Jetfire Cepillo/Quemador
69911	ac	ac	ac	Rotisserie kit Kit de rôtisserie Kit de asador
61427	ac			Cover Couverture Tapa
61527		ac		Cover, Grill Couverture, gril Tapa, Parrilla
61627			ac	Cover, Grill Couverture, gril Tapa, Parrilla
56365		ac		Griddle, Cast Iron Gril en fonte Plancha, Hierro Fundido
56425	ac		ac	Griddle, Cast Iron Gril en fonte Plancha, Hierro Fundido
67732	ac	ac	ac	Charcoal/smoker tray Bac à charbon/fumoir Bandeja Carbón Ahumador
62007	ac	ac	ac	Grease Trays Bacs à graisse Bandejas para Grasa
62020	ac			Drip pan liners
62021		ac		Drip pan liners
62022			ac	Drip pan liners
62045	ac	ac	ac	Grill Maintenance Kit Kit d'entretien du gril Kit de mantenimiento de la parrilla

Exploded View
Vue éclatée
Vista detallada



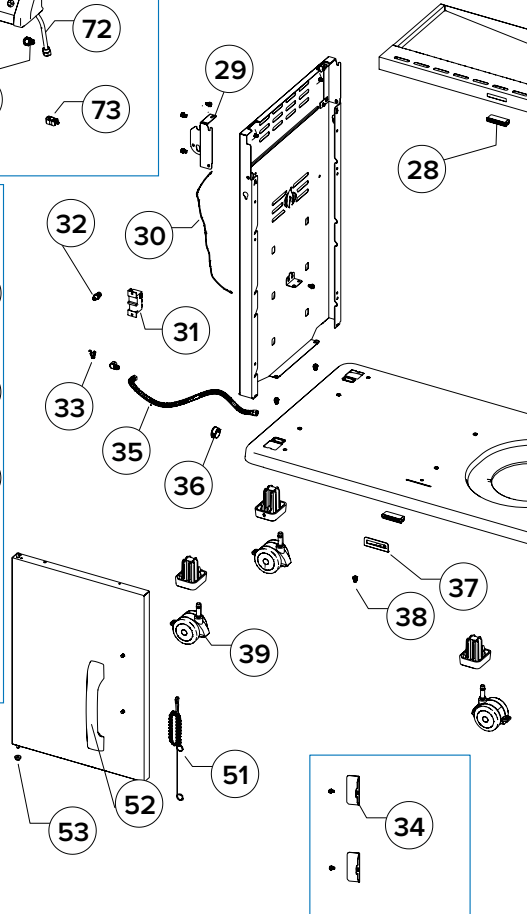
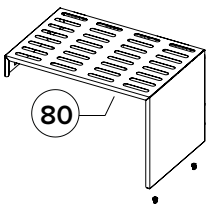
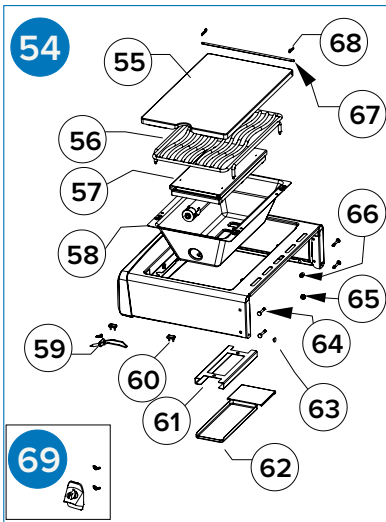
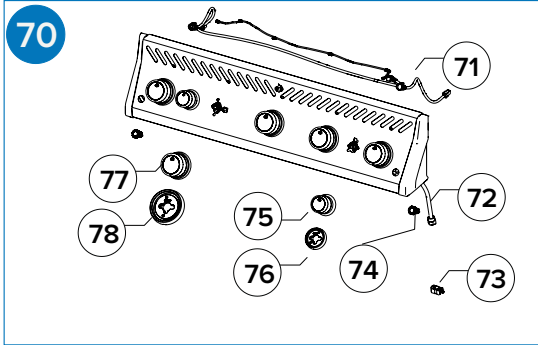
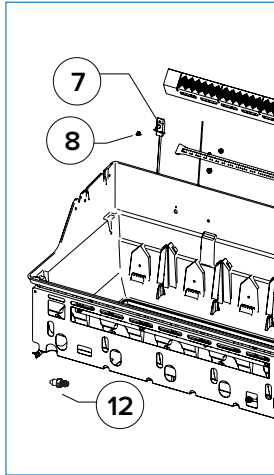
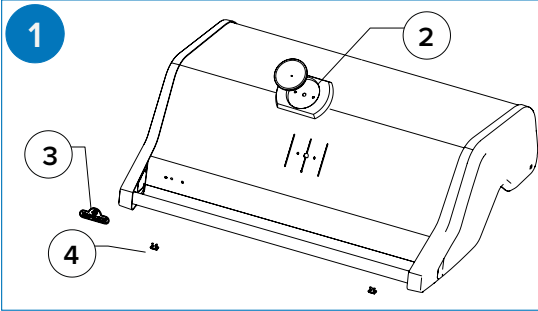

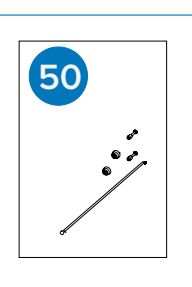
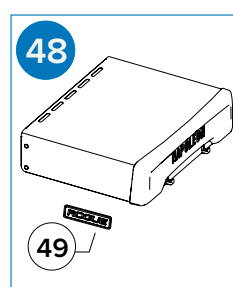
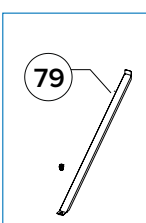
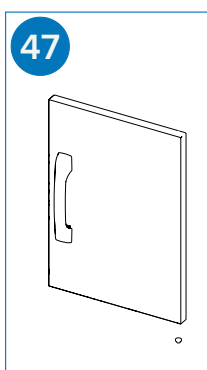
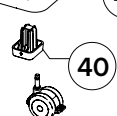
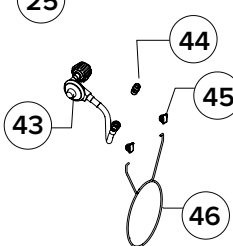
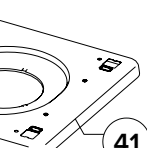
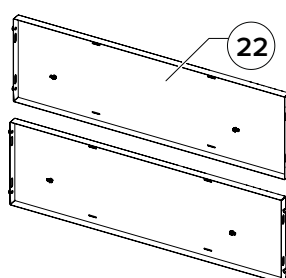
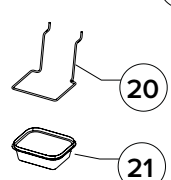
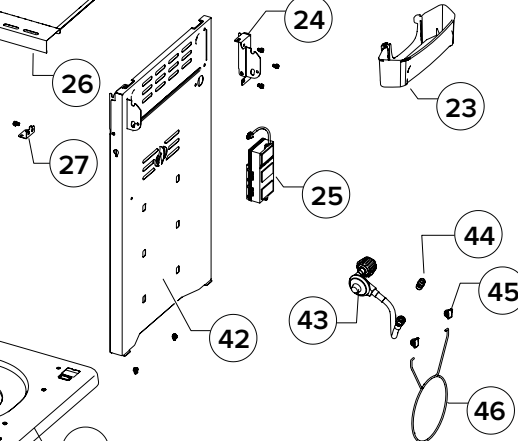
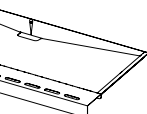
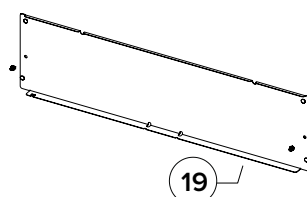
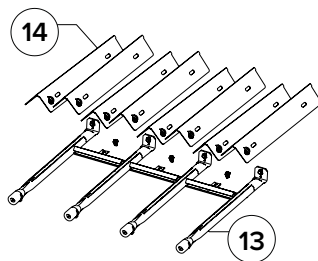
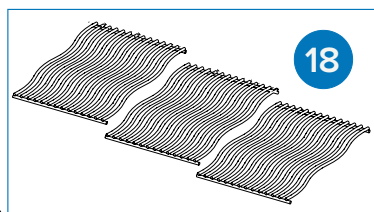
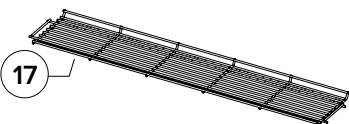
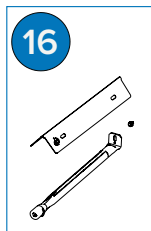
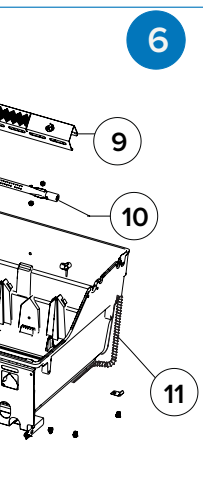

NAPOLEON®

Celebrating over 40 years
delivering home comfort products

Célébrant plus de 40 ans
de produits de confort pour la maison

Celebrando más de 40 años
suministrando productos de confort para el hogar



↑
*Upgrade your
experience.*

*Améliorez votre
expérience.*

*Mejora tu
experiencia.*



NAPOLEON® products are protected by one or more U.S. and Canadian and/or foreign patents or patents pending.

Les produits de NAPOLEON® sont protégés par un ou plusieurs brevets américains, canadiens et/ou étrangers au par des brevets en instance.

Los productos NAPOLEON® están protegidos por una o más patentes o patentes pendientes en E.U., Canadá y/u otros países.



Address | Adresse | Dirección

Wolf Steel Ltd.

24 Napoleon Road,
Barrie, Ontario, L4M 0G8
103 Miller Drive, Crittenden,
Kentucky, USA 41030
7200 Trans Canada Highway,
Montreal, Quebec H4T 1A3



Phone | Téléphone | Teléfono

Canada

1-866-820-8686

Online | En ligne | En línea

 grills@napoleon.com

 www.napoleon.com