

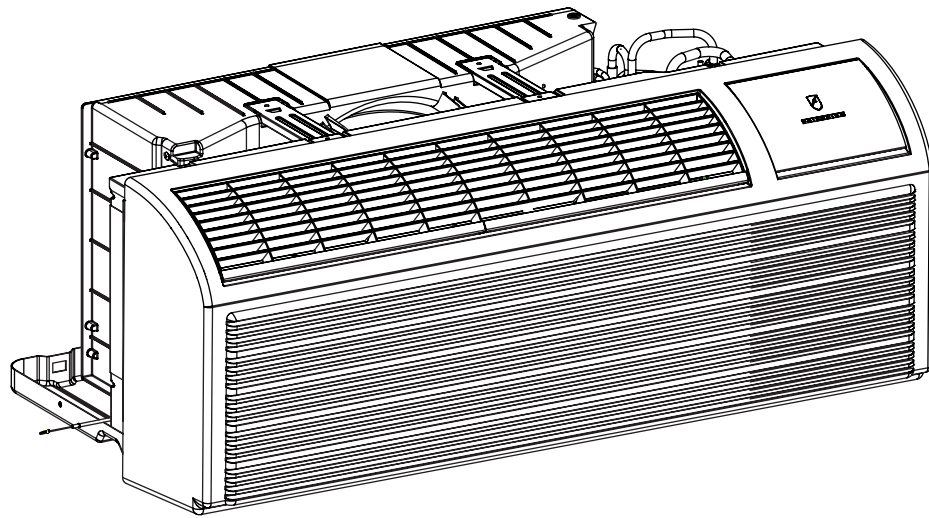

FRIEDRICH

Zoneaire® Select R-32 Series PTAC Packaged Terminal Air Conditioners & Heat Pumps



Standard Chassis Models (R-32 Refrigerant)

Electric Heat

PZE07K3SC, PZE09K3SC, PZE12K3SC, PZE15K5SC
PZE09R3SC, PZE12R3SC

Heat Pump + Electric Heat

PZH07K2SC, PZH07K3SC, PZH09K3SC, PZH12K3SC,
PZH12K5SC, PZH15K3SC, PZH15K5SC
PZH09R3SC, PZH12R3SC

THE EXPERTS IN ROOM AIR CONDITIONING

TABLE OF CONTENTS

Table of Contents

INTRODUCTION	3
Important Safety Information	3
Model Number Reference Guide	7
Serial Number Reference Guide	7
Operation of Equipment in During Construction	8
Typical Unit Components and Dimensions	8
Product Features	9
SPECIFICATIONS	11
Cool w/ Electric Heat (208/230V)	11
Cool w/ Electric Heat (265V)	13
Cool w/ Heat Pump + Electric Heat (208/230V) (7k and 9k BTU)	15
Cool w/ Heat Pump + Electric Heat (208/230V) (12k and 15k BTU)	17
Cool w/ Heat Pump + Electric Heat (208/230V) (12k and 15k BTU)	18
Cool w/ Heat Pump + Electric Heat (265)	19
Electrical Data	22
OPERATION	23
Function and Control	23
System Configuration Fresh Air Vent Control	25
Digital Control Operation	27
Thermostat Installation	28
Auxiliary Controls	29
General Knowledge Sequence Of Refrigeration	30
Refrigerant System Diagram	31
Routine Maintenance	32
Error code and solutions	33
Unit Lost Power	34
Control Panel Does Not Work	35
Malfunction of Temperature Sensor	36
E2/E3/E4/E5	36
E4 Function Error	37
E8 Function Error	38
E9 Function Error	39
Electric Heater Not Running	40
Check Indoor Fan Motor	41
Check Outdoor Fan Motor	42
Check Fan Motor Capacitors	43
Main PCB Board Connector Identification	44
Reversing Valve	45
Checking the Reversing Valve	45
Checking The Reversing Valve Solenoid	45
Compressor Checks	46
UNIT DISASSEMBLY AND COMPONENT REPLACEMENT	48
Remove Chassis	48
Remove Operation panel	49
Open Electrical Control Box	50
Remove Main PCB (logic) Board	51
Remove Power Cord	52
Remove Blower Wheel Housing, Blower wheel, Motor and Electric Heater	53
Remove Outdoor Fan	56
R-32 SEALED SYSTEM REPAIR	57
General Information	57
Required Equipment	59
Refrigerant Removal, Recovery, and Evacuation	60
Component Replacement/Brazing	61
Refrigerant Charging	62
Compressor Replacement	64
Compressor Replacement -Special Procedure in Case of Compressor Burnout	65
WIRING DIAGRAMS	66
PZE	66
PZH	67
APPENDIX	66
Interactive Parts Viewer	68
Limited Warranty	68
Resistance Table of Thermistors (5K)	70
Resistance Table of Thermistors (50K)(Compressor Discharge Sensor	72
Friedrich Authorized Parts Depots	74

INTRODUCTION

Important Safety Information

The information in this manual is intended for use by a qualified technician who is familiar with the safety procedures required for installation and repair, and who is equipped with the proper tools and test instruments required to service this product.

Installation or repairs made by unqualified persons can result in subjecting the unqualified person making such repairs as well as the persons being served by the equipment to hazards resulting in injury or electrical shock which can be serious or even fatal.

Maintenance is the responsibility of the owner. Failure to properly maintain or repair equipment may result in personal injury and/or various types of property damage (fire, flood, etc.).

Safety warnings have been placed throughout this manual to alert you to potential hazards that may be encountered. If you install or perform service on equipment, it is your responsibility to read and obey these warnings to guard against any bodily injury or property damage which may result to you or others.

Due to continuing research in new energy-saving technology, all information in this manual is subject to change without notice.

This service manual is designed to be used in conjunction with the installation and operation manuals provided with each air conditioning system.

This service manual was written to assist the professional service technician to quickly and accurately diagnose and repair malfunctions.

Installation procedures are not given in this manual. They are given in the Installation/Operation manual which can be acquired on the Friedrich [website](#). Click the Link or scan the QR code to be directed to the Professional page where you can locate our technical literature.



SAFETY IS IMPORTANT

We have provided many important safety messages in this manual and on your appliance. Always read and obey all safety messages.



This is a safety Alert symbol. This symbol alerts you to potential hazards that can kill or hurt you and others.

All safety messages will tell you what the potential hazard is, tell you how to reduce the chance of injury, and tell you what will happen if the instructions are not followed.

All safety messages will follow the safety alert symbol with the word "WARNING" or "CAUTION". These words mean:



Indicates a hazard which, if not avoided, can result in severe personal injury or death and damage to product or other property.



Indicates a hazard which, if not avoided, can result in personal injury and damage to product or other property.

NOTICE

Indicates property damage can occur if instructions are not followed.



This symbol indicates that this appliance uses a flammable refrigerant. If the refrigerant is leaked and is exposed to an external ignition source, there is a risk of fire.



This symbol indicates that the Operation Manual should be read carefully.



This symbol indicates that service personnel should be handling this equipment with reference to the installation manual.



This symbol indicates that information is available such as the Installation and Operation manual, or the Service Manual.

INTRODUCTION

⚠️ WARNING: The manufacturer's warranty does not cover any damage or defect to the air conditioner caused by the attachment or use of any components, accessories or devices (other than those authorized by the manufacturer) into, onto or in conjunction with the air conditioner. You should be aware that the use of unauthorized components, accessories or devices may adversely affect the operation of the air conditioner and may also endanger life and property. The manufacturer disclaims any responsibility for such loss or injury resulting from the use of such unauthorized components, accessories or devices.

⚠️ WARNING: This appliance is not intended for use by persons (Including children) with reduced physical, sensory or mental capabilities, or lack of experience and knowledge, unless they have been given supervision or instruction concerning use of the appliance by a person responsible for their safety.

Children should be supervised to ensure that they do not play with the appliance.

⚠️ WARNING: The maximum altitude for this appliance is 2,000 meters(6,562 feet).

Do not use above 2,000 meters(6,562 feet).

⚠️ WARNING: Electrical Shock Hazard

Disconnect all power to the unit before starting maintenance. All electrical connections and wiring **MUST** be installed by a qualified electrician and conform to the National Code and all local codes which have jurisdiction. Failure to do so can result in property damage, severe electrical shock or death.



⚠️ WARNING: Read Installation Manual

Read this manual thoroughly prior to equipment installation or operation. It is the installer's responsibility to properly apply and install the equipment. Installation must be in conformance with the NFPA 70-2023 national electric code or current edition, International Mechanic code 2021 or current edition, and any other local or national codes.



⚠️ WARNING: Safety First

Do not remove, disable, or bypass this unit's safety devices. Doing so may cause fire, injuries, or death.

⚠️ WARNING: This Product uses R-454B Refrigerant

Do not use means to accelerate the defrosting process or to clean, other than those recommended by the manufacturer.

The appliance shall be stored in a room without continuously operating ignition sources (for example: open flames, an operating gas appliance or an operating electric heater).

Do not pierce or burn.

Be aware that refrigerants may not contain an odor.



⚠️ WARNING: Refrigeration System under High pressure

Do not puncture, heat, expose to flame or incinerate. Only certified refrigeration technicians should service this equipment. R454B systems operate at higher pressures than R22 equipment. Appropriate safe service and handling practices must be used.

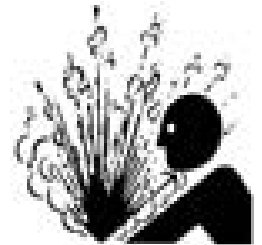

⚠️ CAUTION: Do Not Operate Equipment During Active Stages Of Construction



To ensure proper operation, Friedrich requires that all equipment is not operated during active construction phases. This includes active stages of completing framing, drywalling, spackling, sanding, painting, flooring, and moulding in the equipment's designated conditioning space. The use of this equipment during construction could result in premature failure of the components and/or system and is in violation of our standard warranty guidelines. The operation of newly installed equipment during construction will accelerate the commencement and/or termination of the warranty period.

⚠️ WARNING: Keep all air circulation and ventilation openings free from obstruction.

⚠️ WARNING: The unit should not be in contact with any equipment that will transmit vibration to the unit. Any excessive vibration or pulsation to the unit could result in damage to the refrigerant tubing.

INTRODUCTION

Personal Injury Or Death Hazards

	 WARNING	 AVERTISSEMENT	 ADVERTENCIA
SAFETY FIRST	Do not remove, disable or bypass this unit's safety devices. Doing so may cause fire, injuries, or death.	Ne pas supprimer, désactiver ou contourner cette l'unité des dispositifs de sécurité, faire vous risqueriez de provoquer le feu, les blessures ou la mort.	No eliminar, desactivar o pasar por alto los dispositivos de seguridad de la unidad. Si lo hace podría producirse fuego, lesiones o muerte.

 WARNING
ALWAYS USE INDUSTRY STANDARD PERSONAL PROTECTIVE EQUIPMENT (PPE)

ELECTRICAL HAZARDS:

- Unplug and/or disconnect all electrical power to the unit before performing inspections, maintenance, or service.
- Make sure to follow proper lockout/tag out procedures.
- Always work in the company of a qualified assistant if possible.
- Capacitors, even when disconnected from the electrical power source, retain an electrical charge potential capable of causing electric shock or electrocution.
- Handle, discharge, and test capacitors according to safe, established, standards, and approved procedures.
- Extreme care, proper judgment, and safety procedures must be exercised if it becomes necessary to test or troubleshoot equipment with the power on to the unit.
- Do not spray water on the air conditioning unit while the power is on.
- Electrical component malfunction caused by water could result in electric shock or other electrically unsafe conditions when the power is restored and the unit is turned on, even after the exterior is dry.
- Use air conditioner on a single dedicated circuit within the specified amperage rating.
- Use on a properly grounded outlet only.
- Do not cut or modify the power supply cord or remove the ground prong of the plug.
- Never operate the unit on an extension cord.
- Follow all safety precautions and use proper and adequate protective safety aids such as: gloves, goggles, clothing, properly insulated tools, and testing equipment etc.
- Failure to follow proper safety procedures and/or these warnings can result in serious injury or death.

INTRODUCTION

Personal Injury Or Death Hazards

- **REFRIGERATION SYSTEM REPAIR HAZARDS:**

- Use approved standard refrigerant recovering procedures and equipment to relieve high pressure before opening system for repair.
- Do not allow liquid refrigerant to contact skin. Direct contact with liquid refrigerant can result in minor to moderate injury.
- Be extremely careful when using an oxy-acetylene torch. Direct contact with the torch's flame or hot surfaces can cause serious burns.
- Make certain to protect personal and surrounding property with fire proof materials and have a fire extinguisher at hand while using a torch.
- Provide adequate ventilation to vent off toxic fumes, and work with a qualified assistant whenever possible.
- Always use a pressure regulator when using dry nitrogen to test the sealed refrigeration system for leaks, flushing etc.

- **MECHANICAL HAZARDS:**

- Extreme care, proper judgment and all safety procedures must be followed when testing, troubleshooting, handling, or working around unit with moving and/or rotating parts.
- Be careful when, handling and working around exposed edges and corners of the sleeve, chassis, and other unit components especially the sharp fins of the indoor and outdoor coils.
- Use proper and adequate protective aids such as: gloves, clothing, safety glasses etc.
- Failure to follow proper safety procedures and/or these warnings can result in serious injury or death.

- **PROPERTY DAMAGE HAZARDS**

- **FIRE DAMAGE HAZARDS:**

- Read the Installation/Operation Manual for the air conditioning unit prior to operating.
- Use air conditioner on a single dedicated circuit within the specified amperage rating.
- Connect to a properly grounded outlet only.
- Do not remove ground prong of plug.
- Do not cut or modify the power supply cord.
- Do not use extension cords with the unit.
- Be extremely careful when using acetylene torch and protect surrounding property.
- Failure to follow these instructions can result in fire and minor to serious property damage.

- **WATER DAMAGE HAZARDS:**

- Improper installation, maintenance or servicing of the air conditioner unit can result in water damage to personal items or property.
- Insure that the unit has a sufficient pitch to the outside to allow water to drain from the unit.
- Do not drill holes in the bottom of the drain pan or the underside of the unit.
- Failure to follow these instructions can result in damage to the unit and/or minor to serious property damage.

INTRODUCTION

Model Number Reference Guide

PTAC/PTHP Model Identification Guide										
MODEL NUMBER		P	V	H	09	K	3	F	C	
Series PV = Friedrich Digital PTAC		System H = Heat Pump with Auxiliary Heat		Nominal Capacity 09 = 9,000 Btuh 12 = 12,000 Btuh		Voltage K = 230/208V - 1 Ph. - 60 Hz. R = 265V - 1 Ph. - 60 Hz.		Engineering Digit		
								Design Series		
								Chassis F = FreshAir		
								Nominal Heater Size (230V or 265V) 3 = 3kW		

Serial Number Reference Guide

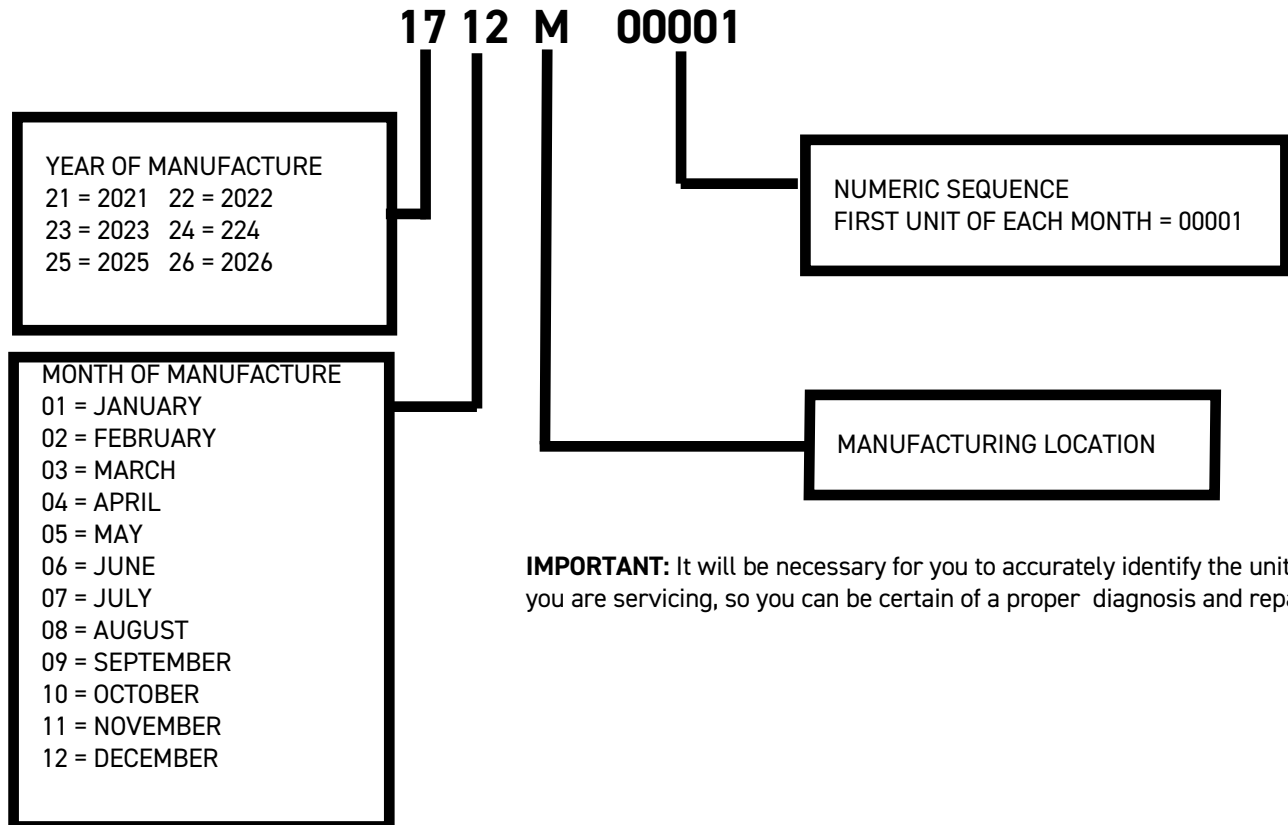

INTRODUCTION

Operation of Equipment in During Construction

- **OPERATION OF EQUIPMENT MUST BE AVOIDED DURING CONSTRUCTION PHASES WHICH WILL PRODUCE AIRBORNE DUST OR CONTAMINATES NEAR OR AROUND AIR INTAKE OPENINGS:**
- Wood or metal framing;
- Drywalling or sheathing,
- Spackling or applying joint compound.
- Sanding or grinding.
- Moulding or trimwork.

NOTICE

Operating the equipment during any phase of active construction noted above can void the equipment's warranty, also leading to poor performance and premature failure

Typical Unit Components and Dimensions

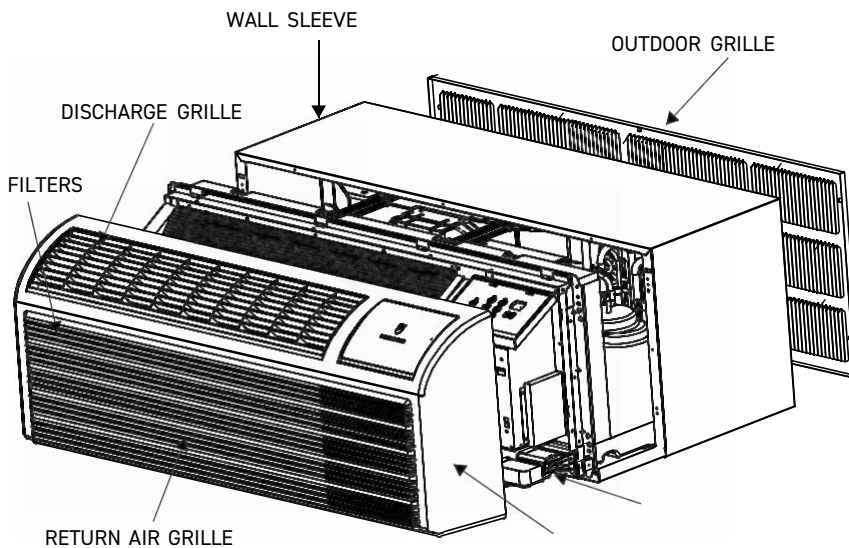

PDXWS Wall Sleeve
Dimensions: 16" H x 42" W x
13- $\frac{3}{4}$ " D
Front Cover Dimensions:
16" H x 42" W x 7- $\frac{3}{4}$ " D

Cut-Out Dimensions:
16- $\frac{1}{4}$ " x 42- $\frac{1}{4}$ "

INTRODUCTION

Product Features

Product Features

The new Friedrich digital PTAC has state of the art features to improve guest comfort, indoor air quality and conserve energy. Through the use of specifically designed control software for the PTAC industry Friedrich has accomplished what other Manufacturer's have only attempted – a quiet, dependable, affordable and easy to use PTAC.

Below is a list of standard features on every Friedrich PTAC and their benefit to the owner.

DIGITAL TEMPERATURE READOUT	By digitally monitoring the desired room temperature, the room is controlled more precisely than conventional systems. The large, easy-to-read LED display can show either the set point or actual room temperature as selected by owner.
INDIVIDUAL MODE & FAN CONTROL BUTTONS	By having separate control buttons and indicators for both fan and mode settings, the Friedrich digital control eliminates the confusion of previous digital PTACs. The accurate temperature setting provides greater guest comfort than other systems.
QUIET START/STOP FAN DELAY	The fan start and stop delays prevent abrupt changes in room acoustics due to the compressor energizing or stopping immediately. Upon call for cooling or heating, the unit fan will run for five seconds prior to energizing the compressor. Also, the fan-off delay allows for "free cooling" by utilizing the already cool indoor coil to its maximum capacity by running for 30 seconds after the compressor.
REMOTE THERMOSTAT OPERATION	Some applications require the use of a wall-mounted thermostat. All new Friedrich PTACs may be switched from unit control to remote thermostat control easily without the need to order a special model or accessory kit.
INTERNAL DIAGNOSTIC PROGRAM	The Friedrich digital PTAC features a self-diagnostic program that can alert maintenance to component failures or operating problems. The internal diagnostic program saves properties valuable time when diagnosing running problems.
FACTORY RUN-TEST	Factory run-tested units reduce problems in the field.
ELECTRONIC TEMPERATURE LIMITING	By limiting the operating range, the property can save energy by eliminating "max cool" or "max heat" situations common with older uncontrolled systems. The new electronic control allows owners to set operating ranges for both heating and cooling independently of one another.
ROOM FREEZE PROTECTION	When the PTAC senses that the indoor room temperature has fallen to 50°F, the unit will cycle on the fan (high) and the electric strip heat to raise the room temperature to 55°F, and then cycle off again. This feature works regardless of the mode selected and can be turned off.
RANDOM COMPRESSOR RESTART	Multiple compressors starting at once can often cause electrical overloads and premature unit failure. The random restart delay eliminates multiple units from starting at once following a power outage or initial power up. The compressor delay will range from 120 to 240 seconds.
CONDENSATE REMOVAL SYSTEM	Condenser fan utilizes slinger ring technology to pick up condensate from the base pan and disperse it on to the condenser coil where it evaporates. This helps to cool the coil and increase the energy efficiency of the unit.

INTRODUCTION

Product Features

DIGITAL DEFROST THERMOSTAT	The PZ-Series uses a digital thermostat to accurately monitor the outdoor coil conditions to allow the heat pump to run whenever conditions are correct. Running the PTAC in heat pump mode saves energy and reduces operating costs. The digital thermostat allows maximization of heat pump run time.
INSTANT HEAT HEAT PUMP MODE	Heat pump models will automatically run the electric heater to quickly bring the room up to temperature when initially energized, then return to heat pump mode. This ensures that the room is brought up to temperature quickly without the usual delay associated with heat pump units.
SEPARATE HEAT/COOL FAN CYCLE CONTROL	The owner may choose between fan cycling or fan continuous mode based on property preference. Fan continuous mode is used to keep constant airflow circulation in the room during all times the unit is 'ON'. Fan cycle will conserve energy by only operating the fan while the compressor or electric heater is operating. The ability to set the fan cycling condition independently between heating and cooling mode will increase user comfort by allowing the choice of only constantly circulating air in the summer or winter time (unlike other PTAC brands that only allow one selection).
EMERGENCY HEAT OVERRIDE	In the event of a compressor failure in heat pump mode, the compressor may be locked out to provide heat through the resistance heater. This feature ensures that even in the unlikely event of a compressor failure, the room temperature can be maintained until the compressor can be serviced.
CENTRAL DESK CONTROL READY	All Friedrich digital PTACs have low voltage terminals ready to connect a central desk control energy management system. Controlling the unit from a remote location like the front desk can reduce energy usage and requires no additional accessories on the PTAC unit.
INDOOR COIL FROST SENSOR	The frost sensor protects the compressor from damage in the event that airflow is reduced or low outdoor temperatures cause the indoor coil to freeze. When the indoor coil reaches 33°F, the compressor is disabled and the fan continues to operate based on demand. Once the coil temperature returns to 59°F, the compressor returns to operation.
ULTRAQUIET AIR SYSTEM	The PZ-Series units feature an indoor fan system design that reduces sound levels without lowering airflow or preventing proper air circulation.
HIGH EFFICIENCY	The Friedrich PTAC has been engineered so that all functional systems are optimized so that they work together to deliver the highest possible performance.
DUAL MOTOR	The dual-motor design means that the indoor motor can run at slower speeds which reduces sound levels indoors.
ROTARY COMPRESSOR	High efficiency rotary compressors are used on all Friedrich PTACs to maximize durability and efficiency.
ALUMINUM ENDPLATES	Outdoor coil endplates made from Aluminum reduce corrosion on the outdoor coil common with other coil designs.
TOP-MOUNTED AIR FILTERS	All Friedrich PTAC return air filters feature an element that has proven to prevent mold and bacterial growth in laboratory testing. PXFTB replacement filter kits feature the same agent. All filters are washable, reusable and easily accessed from the top of the unit without the removal of the front cover.
FILTERED FRESH AIR INTAKE	Friedrich PTAC units are capable of introducing up to 30 CFM of outside air into the conditioned space. The outdoor air passes through a washable mesh screen to prevent debris from entering the airstream.
R-32 REFRIGERANT	Friedrich PTAC units use environmentally-friendly refrigerant.
GOLDFIN TECHNOLOGY	Goldfin Technology protects the outdoor coil from harsh environments.
BREAK-PROOF CONTROL DOOR	Break-proof control door design maintains the integrity of the unit.
GALVANIZED ZINC WALL SLEEVE AND BASE PAN	Galvanized zinc coated steel wall sleeve and steel base pan undergo an 11-step preparation process, are powder coated with a polyester finish and cured in an oven for exceptional durability.

SPECIFICATIONS

Figure 201

Cool w/ Electric Heat (208/230V)

Model			PZE07K3SC	PZE09K3SC	PZE12K3SC	PZE15K5SC
Power supply		V-Ph-Hz	230/208V /60Hz	230/208V/60Hz	230/208V /60Hz	230/208V/60Hz
Power supply type			Single-phase power supply	Single-phase power supply	Single-phase power supply	Single-phase power supply
Cooling	Capacity	Btu/h	7000/6800	9300/9100	12000/11800	14500/14300
	Input	W	585/565	800/785	1110/1090	1450/1430
	EER	Btu/h.W	12/12	11.6/11.6	10.8/10.8	10.0/10.0
	Amps	A	2.6/2.8	3.5/3.8	4.9/5.3	6.4/7.0
Electric heating	Capacity (230/208V)	Btu/h	12000/10000	12000/10000	12000/10000	17000/13900
	Power input (230/208V)	W	3650/2990	3650/2990	3650/2990	5050/4135
	Rated current (230/208V)	A	15.9/14.3	15.9/14.3	15.9/14.3	21.9/19.8
Sensible Heat Ratio			89%	86.7%	76.5%	68.1%
Moisture Removal		pints/hr	0.69	1.37/1.69	2.32/2.56	4.29/4.44
MCA		A	20	20	20	30
MOP		A	20	20	20	30
Power factor			0.93/0.95	0.97/0.98	0.99/0.98	0.99/0.98
Max. input consumption		W	850	1050	1450	2050
Max. current		A	3.9	5.3	8.0	11
Compressor	Compressor		39X142GA\$54LY	39X192GD&5JLA	44X2623KTFJMZ	44X362KK&FJMD
	Type		Rotary	Rotary	Rotary	Rotary
	Brand		RECHI	RECHI	RECHI	RECHI
	Capacity	Btu/h	6050 ± 5 %	8470± 5 %	11565±5%	16150±5%
	Input	W	470 ± 5 %	650 ± 5 %	855 ±5%	1225 ±5%
	Rated current(RLA)	A	2.4	3.4	4.5	6.4
	Locked rotor Amp(LRA)	A	13.4±10%	17.5±10%	23.9±10%	34.7±10%
	Thermal protector	°F	275±13(Built-in)	275±13(Built-in)	311±9(Built-in)	293±9(Built-in)
	Capacitor	uF	15	25	30	30
	Refrigerant oil	ml	FW68DA 160ml	FW68DA 180ml	FW68DA 240ml	FW68DA 320ml
Indoor fan motor	Model		YDK-25-4-1	YDK-25-4-1	YDK-25-4-1	YDK-25-4-1
	Brand		Li Feng	Li Feng	Li Feng	Li Feng
	Insulation class		B	B	B	B
	Input	W	60	60	70	70
	Output	W	25	25	25	25
	Rated current	A	0.3	0.3	0.4	0.4
	Capacitor	uF	2	2	2	2
	Speed(hi/mi/lo)	r/min	900/850	1000/850	1150/900	1150/900
Indoor air flow (Hi/Lo)		cfm	350/330	390/330	450/340	450/340
Indoor Fan Noise Level(230V)		dBA	49/44	49/44	52/45	53/46
Indoor Fan Noise Level(208V)		dBA	49/44	49/44	52/45	52/46
Indoor Fan Noise Level((230V) cooling mode		dBA	53/51	52/50	54/52	54/50

SPECIFICATIONS

Figure 201

Cool w/ Electric Heat (208/230V)

Model			PZE07K3SC	PZE09K3SC	PZE12K3SC	PZE15K5SC
Indoor Fan Noise Level(208V) cooling mode		dBA	52/50	52/50	54/51	53/50
Indoor sound level (sound pressure level) (Fan mode)		dB(A)±2	49/44	49/40	52/45	52/45
Outdoor fan motor	Model		YDK-55-4P2-4	YDK-55-4P2-4	YDK-AI-55-4P2	YDK-55-4P2-4
	Brand		chigo/KB	chigo/KB	chigo/KB	chigo/KB
	Insulation class		A	A	A	A
	Safe class		IPX4	IPX4	IPX4	IPX4
	Input	W	104	104	104	104
	Output	W	55	55	55	55
	Rated current	A	0.5	0.5	0.5	0.5
	Capacitor	uF	3	3	3	3
	Speed	r/min	1600	1600	1600	1600
Outdoor fan	material		ABS+G15	ABS+G15	ABS+G15	ABS+G15
	Type		Axial flow	Axial flow	Axial flow	Axial flow
	Diameter	in.	13 3/4	13 3/4	13 3/4	13 3/4
	Height	in.	4 1/8	4 1/8	4 1/8	4 1/8
Outdoor air flow		cfm	706	706	706	706
Outdoor sound level(sound pressure level)(Heating mode)		dB(A)±2	67	67	66	66
Unit	Dimension(W*H*D)	in.	42*21*16	42*21*16	42*21*16	42*21*16
	Packing (W*H*D)	in.	45*25*19	45*25*19	45*25*19	45*25*19
	Net/Gross weight	lbs	90/103	94/105	106/117	107/118
Charged refrigerant type		oz	17.6	18.7	21.5	27.5
Throttle type			Capillary	Capillary	Capillary	Capillary
Design pressure		PSI	493/232	493/232	493/232	493/232
Power Cord plug			LCDI-20A	LCDI-20A	LCDI-20A	LCDI-30A
Controller			Control panel; (Optional: Remote control /24V wired control)	Control panel; (Optional: Remote control /24V wired control)	Control panel; (Optional: Remote control /24V wired control)	Control panel; (Optional: Remote control /24V wired control)
Operation temp		°F	60-90	60-90	60-90	60-90
Ambient temp	cooling	°F	53-114	53-114	53-114	53-114
Ambient temp	hating	°F	35-75	35-75	35-75	35-75

SPECIFICATIONS

Figure 202

Cool w/ Electric Heat (265V)

Model			PZE09R3SC	PZE12R3SC
Power supply		V-Ph-Hz	265V/60Hz	265V/60Hz
Power supply type			Single-phase power 1Ph	Single-phase power 1Ph
Cooling	Capacity	Btu/h	9000	12300
	Input	W	780	1150
	EER	Btu/h.W	11.5	10.7
	Amps	A	3.1	5.1
Electric heating	Capacity (230/208V)	Btu/h	12000	12000
	Power input (230/208V)	W	3650	3650
	Rated current (230/208V)	A	13.8	13.8
Sensible Heat Ratio			84.8%	75.7%
Moisture Removal		pints/hr	1.1	2.8
MCA		A	20	20
MOP		A	15	15
Power factor			1.0	1.0
Max. input consumption		W	1040	1400
Max. current		A	4.4	5.9
Compressor	Compressor		KSN71U11VDZ	KSM103U11UFZ
	Type		rotary	rotary
	Brand		GMCC	GMCC
	Capacity	Btu/h	8751± 5 %	10370±5%
	Input	W	645± 5 %	1125 ±5%
	Rated current(RLA)	A	2.5	4.3
	Locked rotor Amp(LRA)	A	16± 10%	21+ 10 %
	Thermal protector	°F	293±9(Built-in)	293±9(Built-in)
	Capacitor	uF	15	25
	Refrigerant oil	ml	190± 10	300± 15
Indoor fan motor	Model		YDK-25-4-1	YDK-25-4-1
	Brand		Li Feng	Li Feng
	Insulation class		B	B
	Input	W	60	70
	Output	W	25	25
	Rated current	A	0.3	0.4
	Capacitor	uF	2	2
	Speed(hi/mi/lo)	r/min	1000/850	1150/900
Indoor air flow (Hi/Lo)		cfm	390/330	450/340
Indoor Fan Noise Level(265V)		dBA	49/45(265v)	52/46(265v)
Indoor Fan Noise Level((265V))cooling mode		dBA	52/50(265v)	55/52(265v)
Indoor sound level (sound pressure level) (Fan mode)		dB(A)±2	49/45	52/46

SPECIFICATIONS

Figure 202

Cool w/ Electric Heat (265V)

Model			PZE09R3SC	PZE12R3SC
Outdoor fan motor	Model		YDK-45-4P2	YDK-45-4P2
	Brand		KB	KB
	Insulation class		A	A
	Safe class		IPX4	IPX4
	Input	W	90	90
	Output	W	45	45
	Rated current	A	0.3	0.3
	Capacitor	uF	2	2
	Speed	r/min	1600	1680
Outdoor fan	material		ABS+G15	ABS+G15
	Type		axial flow	axial flow
	Diameter	in.	13 3/4	13 3/4
	Height	in.	4 1/8	4 1/8
Outdoor air flow		cfm	706	706
Outdoor sound level(sound pressure level)(Heating mode)		dB(A)±2	66	66
Unit	Dimension(W*H*D)	in.	42*21*16	42*21*16
	Packing (W*H*D)	in.	45*25*19	45*25*19
	Net/Gross weight	lbs	94/105	94/105
Charged refrigerant type		oz	19	22.2
Throttle type			Capillary	Capillary
Design pressure		PSI	493/232	493/232
Power Cord plug			(20A)	(20A)
Controller			push-button control	push-button control
Operation temp		°F	60-90	60-90
Ambient temp	cooling	°F	53-114	53-114
Ambient temp	heating	°F	35-75	35-75

SPECIFICATIONS

Figure 203

Cool w/ Heat Pump + Electric Heat (208/230V) (7k and 9k BTU)

Model			PZH07K2SC	PZH07K3SC	PZH09K3SC
Power supply		V-Ph-Hz	230/208V /60Hz	230/208V /60Hz	230/208V/60Hz
Power supply type			Single-phase power supply	Single-phase power supply	Single-phase power supply
Cooling	Capacity	Btu/h	7000/6800	7000/6800	9200/9000
	Input	W	590/570	590/570	805/790
	EER	Btu/h.W	11.9/11.9	11.9/11.9	11.4/11.4
	Amps	A	2.6/2.8	2.6/2.8	3.6/3.9
Heating	Capacity	Btu/h	6000/5800	6000/5800	8000/7800
	Input	W	500/485	500/485	690/670
	COP	W/W	3.5/3.5	3.5/3.5	3.4/3.4
	Amps	A	2.3/2.4	2.3/2.4	3.1/3.3
Electric heating	Capacity (230/208V)	Btu/h	8500/6900	12000/10000	12000/10000
	Power input (230/208V)	W	2550/2090	3650/2990	3650/2990
	Rated current (230/208V)	A	11.1/10	15.9/14.3	15.9/14.3
Sensible Heat Ratio			89%	89%	85.9%
Moisture Removal		pints/hr	0.69	0.69	1.37/1.69
MCA		A	15	20	20
MOP		A	15	20	20
Power factor			0.93/0.95	0.93/0.95	0.97/0.98
Max. input consumption		W	850	850	1050
Max. current		A	3.9	3.9	5.3
Compressor	Compressor		39X142GA\$54LY	39X142GA\$54LY	39X192GD&5JLA
	Type		Rotary	Rotary	Rotary
	Brand		RECHI	RECHI	RECHI
	Capacity	Btu/h	6050 ± 5 %	6050 ± 5 %	8470± 5 %
	Input	W	470 ± 5 %	470 ± 5 %	650 ± 5 %
	Rated current(RLA)	A	2.4	2.4	3.4
	Locked rotor Amp(LRA)	A	13.4±10%	13.4±10%	17.5±10%
	Thermal protector	°F	275±13(Built-in)	275±13(Built-in)	275±13(Built-in)
	Capacitor	uF	15	15	25
	Refrigerant oil	ml	FW68DA 160ml	FW68DA 160ml	FW68DA 180ml
Indoor fan motor	Model		YDK-25-4-1	YDK-25-4-1	YDK-25-4-1
	Brand		Li Feng	Li Feng	Li Feng
	Insulation class		B	B	B
	Input	W	60	60	60
	Output	W	25	25	25
	Rated current	A	0.3	0.3	0.3
	Capacitor	uF	2	2	2
	Speed(hi/mi/lo)	r/min	900/850	900/850	1000/850
Indoor air flow (Hi/Lo)		cfm	350/330	350/330	390/330
Indoor Fan Noise Level(230V)		dBA	49/44	49/44	49/44
Indoor Fan Noise Level(208V)		dBA	49/44	49/44	49/44
Indoor Fan Noise Level((230V))cooling mode		dBA	53/51	53/51	52/50
Indoor Fan Noise Level(208V)cooling mode		dBA	52/50	52/50	52/50

SPECIFICATIONS

Figure 203

Cool w/ Heat Pump + Electric Heat (208/230V) (7k and 9k BTU)

Model			PZH07K2SC	PZH07K3SC	PZH09K3SC
Indoor Fan Noise Level(230V)heating mode		dB(A)	53/51	53/51	52/50
Indoor Fan Noise Level(208V)heating mode		dB(A)	52/51	52/51	51/50
Indoor sound level (sound pressure level) (Fan mode)		dB(A)±2	49/44	49/44	49/44
Outdoor fan motor	Model		YDK-55-4P2-4	YDK-55-4P2-4	YDK-55-4P2-4
	Brand		chigo/KB	chigo/KB	chigo/KB
	Insulation class		A	A	A
	Safe class		IPX4	IPX4	IPX4
	Input	W	104	104	104
	Output	W	55	55	55
	Rated current	A	0.5	0.5	0.5
	Capacitor	uF	3	3	3
	Speed	r/min	1600	1600	1600
Outdoor fan	material		ABS+G15	ABS+G15	ABS+G15
	Type		Axial flow	Axial flow	Axial flow
	Diameter	in.	13 3/4	13 3/4	13 3/4
	Height	in.	4 1/8	4 1/8	4 1/8
Outdoor air flow		cfm	706	706	706
Outdoor sound level(sound pressure level) (Heating mode)		dB(A)±2	67	67	67
Unit	Dimension(W*H*D)	in	42*21*16	42*21*16	42*21*16
	Packing (W*H*D)	in	45*25*19	45*25*19	45*25*19
	Net/Gross weight	lbs	92.6/104	92.6/104	95/106
Charged refrigerant type		oz	17.6	17.6	18.7
Throttle type			capillary	capillary	capillary
Design pressure		PSI	493/232	493/232	493/232
Power Cord plug			LCDI-15A	LCDI-20A	LCDI-20A
Controller			Control panel; (Optional: Remote control /24V wired control)	Control panel; (Optional: Remote control /24V wired control)	Control panel; (Optional: Remote control /24V wired control)
Operation temp		°F	60-90	60-90	60-90
Ambient temp	cooling	°F	53-114	53-114	53-114
Ambient temp	hating	°F	35-75	35-75	35-75

SPECIFICATIONS

Figure 204

Cool w/ Heat Pump + Electric Heat (208/230V) (12k and 15k BTU)

Friedrich Model			PZH12K3SC	PZH12K5SC	PZH15K5SC	PZH15K3SC
Power supply		V-Ph-Hz	230/208V /60Hz	230/208V /60Hz	230/208V /60Hz	230/208V /60Hz
Power supply type			Single-phase power supply	Single-phase power supply	Single-phase power supply	Single-phase power supply
Cooling	Capacity	Btu/h	12000/11800	12000/11800	14500/14300	14500/14300
	Input	W	1130/1110	1130/1110	1450/1430	1450/1430
	EER	Btu/h.W	10.6/10.6	10.6/10.6	10.0/10.0	10.0/10.0
	Amps	A	5.0/5.4	5.0/5.4	6.4/7.0	6.4/7.0
Heating	Capacity	Btu/h	10400/10200	10400/10200	13600/13200	13600/13200
	Input	W	895/880	895/880	1245/1210	1245/1210
	COP	W/W	3.4/3.4	3.4/3.4	3.2/3.2	3.2/3.2
	Amps	A	4.0/4.4	4.0/4.4	5.5/6.0	5.5/6.0
Electric heating	Capacity (230/208V)	Btu/h	12000/10000	17000/13900	17000/13900	12000/10000
	Power input (230/208V)	W	3650/2990	5050/4135	5050/4135	3650/2990
	Rated current (230/208V)	A	15.9/14.3	21.9/19.8	21.9/19.8	15.9/14.3
Sensible Heat Ratio			78.3%	78.3%	68.6%	68.6%
Moisture Removal		pints/hr	2.32/2.56	2.32/2.56	4.29/4.44	4.29/4.44
MCA		A	20	30	30	20
MOP		A	20	30	30	20
Power factor			0.99/0.98	0.99/0.98	0.99/0.98	0.99/0.98
Max. input consumption		W	1450	1450	2050	2050
Max. current		A	8.0	8.0	11	11
Compressor	Compressor		44X2623KTFJMZ	44X2623KTFJMZ	44X362KK&FJMD	44X362KK&FJMD
	Type		Rotary	Rotary	Rotary	Rotary
	Brand		RECHI	RECHI	RECHI	RECHI
	Capacity	Btu/h	11565±5%	11565±5%	16150±5%	16150±5%
	Input	W	855 ±5%	855 ±5%	1225 ±5%	1225 ±5%
	Rated current(RLA)	A	4.5	4.5	6.4	6.4
	Locked rotor Amp(LRA)	A	23.9±10%	23.9±10%	34.7±10%	34.7±10%
	Thermal protector	°F	311±9(Built-in)	311±9(Built-in)	293±9(Built-in)	293±9(Built-in)
	Capacitor	uF	30	30	30	30
	Refrigerant oil	ml	FW68DA 240ml	FW68DA 240ml	FW68DA 320ml	FW68DA 320ml
Indoor fan motor	Model		YDK-25-4-1	YDK-25-4-1	YDK-25-4-1	YDK-25-4-1
	Brand		Li Feng	Li Feng	Li Feng	Li Feng
	Insulation class		B	B	B	B
	Input	W	70	70	70	70
	Output	W	25	25	25	25
	Rated current	A	0.4	0.4	0.4	0.4
	Capacitor	uF	2	2	2	2
	Speed(hi/mi/lo)	r/min	1150/900	1150/900	1150/900	1150/900
Indoor air flow (Hi/Lo)		cfm	450/340	450/340	450/340	450/340
Indoor Fan Noise Level(230V)		dBA	52/45	52/45	53/46	53/46
Indoor Fan Noise Level(208V)		dBA	52/45	52/45	52/46	52/46

SPECIFICATIONS

Figure 204

Cool w/ Heat Pump + Electric Heat (208/230V) (12k and 15k BTU)

Friedrich Model		PZH12K3SC	PZH12K5SC	PZH15K5SC	PZH15K3SC
Indoor Fan Noise Level((230V))cooling mode	dBA	54/52	54/52	54/50	54/50
Indoor Fan Noise Level(208V)cooling mode	dBA	54/51	54/51	53/50	53/50
Indoor Fan Noise Level(230V)heating mode	dBA	54/52	54/52	54/51	54/51
Indoor Fan Noise Level(208V)heating mode	dBA	54/51	54/51	53/50	53/50
Indoor sound level (sound pressure level) (Fan mode)	dB(A)±2	52/45	52/45	52/46	52/46
Outdoor fan motor	Model	YDK-AI-55-4P2	YDK-AI-55-4P2	YDK-55-4P2-4	YDK-55-4P2-4
	Brand	chigo/KB	chigo/KB	chigo/KB	chigo/KB
	Insulation class	A	A	A	A
	Safe class	IPX4	IPX4	IPX4	IPX4
	Input	W	104	104	104
	Output	W	55	55	55
	Rated current	A	0.5	0.5	0.5
	Capacitor	uF	3	3	3
	Speed	r/min	1600	1600	1600
Outdoor fan	material	ABS+G15	ABS+G15	ABS+G15	ABS+G15
	Type	Axial flow	Axial flow	Axial flow	Axial flow
	Diameter	in.	13 3/4	13 3/4	13 3/4
	Height	in.	4 1/8	4 1/8	4 1/8
Outdoor air flow	cfm	706	706	706	706
Outdoor sound level(sound pressure level)(Heating mode)	dB(A)±2	66	66	66	66
Unit	Dimension(W*H*D)	in	42*21*16	42*21*16	42*21*16
	Packing (W*H*D)	in	45*25*19	45*25*19	45*25*19
	Net/Gross weight	lbs	107/118	107/118	108/119
Charged refrigerant type	oz	21.5	21.5	27.5	27.5
Throttle type		capillary	capillary	capillary	capillary
Design pressure	PSI	493/232	493/232	493/232	493/232
Power Cord plug		LCDI-20A	LCDI-30A	LCDI-30A	LCDI-20A
Controller		Control panel; (Optional: Remote control /24V wired control)	Control panel; (Optional: Remote control /24V wired control)	Control panel; (Optional: Remote control /24V wired control)	Control panel; (Optional: Remote control /24V wired control)
Operation temp	°F	60-90	60-90	60-90	60-90
Ambient temp cooling	°F	53-114	53-114	53-114	53-114
Ambient temp heating	°F	35-75	35-75	35-75	35-75

SPECIFICATIONS

Figure 205

Cool w/ Heat Pump + Electric Heat (265)

Model			PZH09R3SC	PZH12R3SC
Power supply		V-Ph-Hz	265V/60Hz	265V/60Hz
Power supply type			Single-phase power 1Ph	Single-phase power 1Ph
Cooling	Capacity	Btu/h	9000	12300
	Input	W	780	1150
	EER	Btu/h.W	11.5	10.7
	Amps	A	3.1	5.1
Heating	Capacity	Btu/h	8200	10800
	Input	W	685	1005
	COP	W/W	3.5	3.2
	Amps	A	3.1	4.5
Electric heating	Capacity (230/208V)	Btu/h	12000	12000
	Power input (230/208V)	W	3650	3650
	Rated current (230/208V)	A	13.8	13.8
Sensible Heat Ratio			86%	75.3%
Moisture Removal		pints/hr	1.1	2.8
MCA		A	20	20
MOP		A	15	15
Power factor			1.0	1.0
Max. input consumption		W	1040	1400
Max. current		A	4.4	5.9
Compressor	Compressor		KSN71U11VDZ	KSM103U11UFZ
	Type		rotary	rotary
	Brand		GMCC	GMCC
	Capacity	Btu/h	8751± 5 %	10370±5%
	Input	W	645± 5 %	1125 ±5%
	Rated current(RLA)	A	2.5	4.3
	Locked rotor Amp(LRA)	A	16± 10%	21+ 10 %
	Thermal protector	°F	293±9(Built-in)	293±9(Built-in)
	Capacitor	uF	15	25
	Refrigerant oil	ml	190± 10	300± 15
Indoor fan motor	Model		YDK-25-4-1	YDK-25-4-1
	Brand		Li Feng	Li Feng
	Insulation class		B	B
	Input	W	60	70
	Output	W	25	25
	Rated current	A	0.3	0.4
	Capacitor	uF	2	2
	Speed(hi/mi/lo)	r/min	1000/850	1150/900
Indoor air flow (Hi/Lo)		cfm	390/330	450/340
Indoor Fan Noise Level(230V)		dBA	49/45(265v)	52/46(265v)
Indoor Fan Noise Level(208V)		dBA	/	/
Indoor Fan Noise Level((230V))cooling mode		dBA	51/49(265v)	55/52(265v)

SPECIFICATIONS

Figure 205

Cool w/ Heat Pump + Electric Heat (265)

Indoor Fan Noise Level(208V)cooling mode		dBA	/	/
Indoor Fan Noise Level(230V)heating mode		dBA	51/50(265v)	54/51(265v)
Indoor Fan Noise Level(208V)heating mode		dBA	/	/
Indoor sound level (sound pressure level) (Fan mode)		dB(A)±2	49/45	52/46
Outdoor fan motor	Model		YDK-45-4P2	YDK-45-4P2
	Brand		KB	KB
	Insulation class		A	A
	Safe class		IPX4	IPX4
	Input	W	90	90
	Output	W	45	45
	Rated current	A	0.3	0.3
	Capacitor	uF	2	2
	Speed	r/min	1600	1600
Outdoor fan	material		ABS+G15	ABS+G15
	Type		axial flow	axial flow
	Diameter	in.	13 3/4	13 3/4
	Height	in.	4 1/8	4 1/8
Outdoor air flow		cfm	706	706
Outdoor sound level(sound pressure level)(Heating mode)		dB(A)±2	66	66
Unit	Dimension(W*H*D)	mm	42*21*16	42*21*16
	Packing (W*H*D)	mm	45*25*19	45*25*19
	Net/Gross weight	lbs	94/105	94/105
Charged refrigerant type		oz	19	22.2
Throttle type			Capillary	Capillary
Design pressure		PSI	493/232	493/232
Power Cord plug			(20A)	(20A)
Controller			Push-button control	Push-button control
Operation temp		°F	60-90	60-90
Ambient temp	cooling	°F	53-114	53-114
Ambient temp	heating	°F	35-75	35-75

SPECIFICATIONS

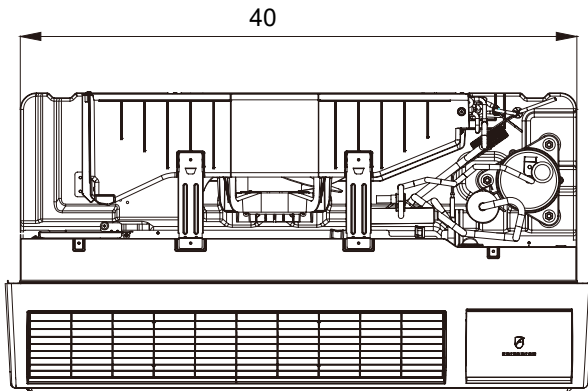
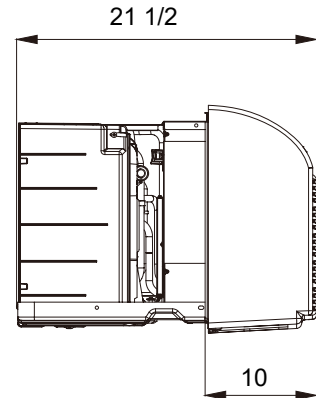
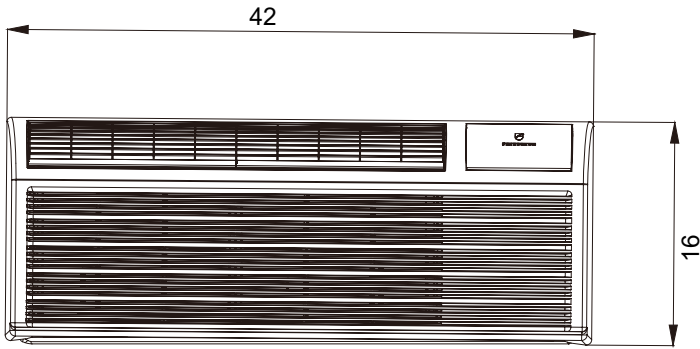

Unit:inch

Figure 205 (Chassis Specs)

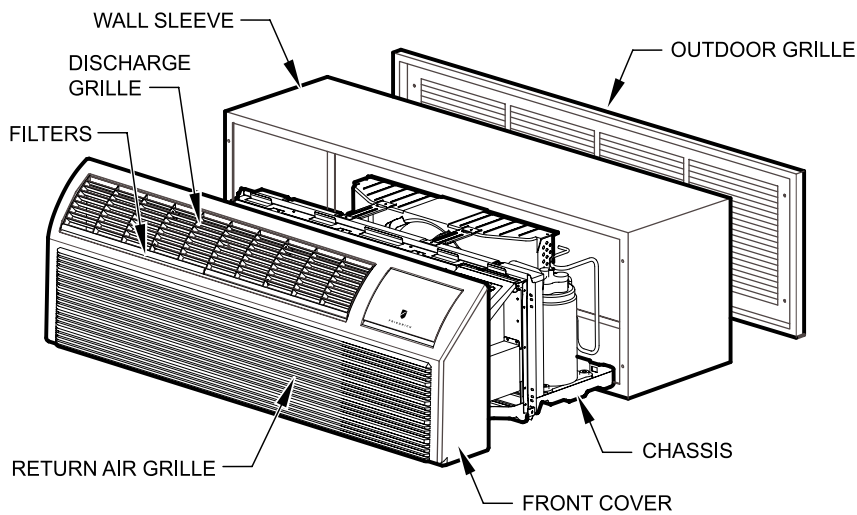

PDXWS Wall Sleeve Dimensions:
16" H x 42" W x 13-³/₄" D

Front Cover Dimensions:
16" H x 42" W x 7-³/₄" D

Cut-Out Dimensions:
16-¹/₄" x 42-¹/₄"

Figure 206 (Typical Unit Components and Dimensions)





SPECIFICATIONS

Electrical Data

A. Electrical Rating Tables

All units are equipped with standard power cords.

NOTE: Use Copper Conductors ONLY. Wire sizes are per NEC, check local codes for overseas applications.

Voltage	230V			265V
	15	20	30	20
Amps	15	20	30	20
Heater Size	2.5kW	3.6kW	5.0kW	3.6kW
Receptacles				
NEMA# Receptacle	6-15R	6-20R	6-30R	7-20R
NEMA# Plug	6-15P	6-20P	6-30P	7-20P

FUSE/CIRCUIT BREAKER	Use ONLY type and size fuse or HACR circuit breaker indicated on unit's rating plate. Proper current protection to the unit is the responsibility of the owner. NOTE: A time delay fuse is provided with 265V units.
GROUNDING	Unit MUST be grounded from branch circuit through service cord to unit, or through separate ground wire provided on permanently connected units. Be sure that branch circuit or general purpose outlet is grounded. The field supplied outlet must match plug on service cord and be within reach of service cord. Refer to Table 1 for proper receptacle and fuse type. Do NOT alter the service cord or plug. Do NOT use an extension cord.
RECEPTACLE	The field supplied outlet must match plug on service cord and be within reach of service cord. Refer to Table 1 for proper receptacle and fuse type. Do NOT alter the service cord or plug. Do NOT use an extension cord.

⚠ WARNING



Electrical Shock Hazard

Turn off electrical power before service or installation.

ALL electrical connections and wiring **MUST** be installed by a qualified electrician and conform to the National Code and all local codes which have jurisdiction.

Failure to do so can result in property damage, personal injury and/or death.

B. Power Cord Information (230/208V models only)

All Friedrich 230/208V PTAC units are shipped from the factory with a Leakage Current Detection Interrupter (LCDI) equipped power cord. The LCDI device meets the UL and NEC requirements for cord connected air conditioners effective August 2004.

To test your power supply cord:

1. Plug power supply cord into a grounded 3 prong outlet.
2. Press RESET.
3. Press TEST (listen for click; Reset button trips and pops out).
4. Press and release RESET (listen for click; Reset button latches and remains in). The power supply cord is ready for operation.

NOTE: The LCDI device is not intended to be used as a switch. Once plugged in the unit will operate normally without the need to reset The LCDI device.

If the LCDI device fails to trip when tested or if the power supply cord is damaged it must be replaced with a new supply cord obtained from the product manufacturer, and must not be repaired.

Figure 14
Typical LCDI Devices



15/20A/30A LCDI Device

FRP014

OPERATION

Function and Control

Buttons and Display

1) Buttons

There are ON/OFF, UP, DOWN, HEAT, COOL, CONSTANT FAN and fan speed of HIGH, LOW, AUTO buttons.

1. ON/OFF: Press to turn power on or off to the unit.
2. COOL, HEAT: choose the mode of operation
3. HIGH, LOW, AUTO: choose the fan speed.
4. UP, DOWN: Adjust the setting temperature , default: 60-90°F(16~32°F).

2) Dual 8 Digital Tube Display and LED

Two 8 digital tube and 7 LEDs (ON/OFF, HIGH, LOW, AUTO, HEAT, COOL, CONSTANT FAN)

1. Mode LED display: when the unit is running in a certain mode, the corresponding LED is lit up.
2. ON/OFF LED: at ON status, the LED is lit up.
3. CONSTANT FAN LED: when this function is enabled, the LED is lit up.
4. Fan speed LED: when the unit is running at HIGH, LOW or AUTO fan speed, the corresponding LED is lit up.
5. Dual 8 digital tube display normally, it displays the indoor ambient temperature. When the UP/DOWN button is pressed it displays the setting temperature. If an error occurs, it displays the ERROR CODE (See Troubleshooting Section - Diagnostic Codes).

The LED close to the button indicates the current status (lit up means effective).

Temperature Parameter

Indoor setting temperature (Ts)

Indoor ambient temperature (T1)

System Basic Function

Once the compressor starts, the compressor won't stop with the change of the indoor temperature. Once the compressor stops, it can only start after a 3 mins delay. (The compressor can stop immediately at the time of mode switch over, turning off the unit, adjusting setting temperature and turning off from a function error.)

1) Cooling Mode

Working conditions and process for cooling:

When $T1 \geq Ts + 2^\circ\text{F}$, the unit is running in cooling mode. Meanwhile, the compressor is running and the fan is running at the setting fan speed;

When $T1 \leq Ts - 2^\circ\text{F}$, the compressor is OFF. Meanwhile, the fan will run at the setting fan speed for 15s (CONSTANT FAN OFF); or run at the setting speed continuously (CONSTANT FAN ON);

When $Ts - 2^\circ\text{F} < T1 < Ts + 2^\circ\text{F}$, the unit keeps previous running status.

2) Heating Mode

Working condition and process for heating:

When $T1 < Ts - 2^\circ\text{F}$, the unit is running in heating mode. Heat pump or electric heating will start depending on the ambient temperature condition or the heating priority setting (#4 DIP SWITCH, ON- for heat pump and OFF-for electric heating).

When $T1 \geq Ts + 2^\circ\text{F}$, the heating is turned OFF. Meanwhile, the fan will run at the setting fan speed for 15 sec or 1 minute delay (CONSTANT FAN OFF) or run at the setting speed continuously (CONSTANT FAN ON).

When $Ts - 2^\circ\text{F} < T1 < Ts + 2^\circ\text{F}$, the unit keeps at the previous running status.

Electric heater does not work with heat pump at the same time. When $T1 < 41^\circ\text{F}$ (5°C) unit will run the electric heater, when $T1 \geq 41^\circ\text{F}$ the unit will run heat pump.

3) Room Freeze Protection (AUTO HEATING)

This is valid only in standby mode. The dual 8 digital tube displays "L0".

Entry condition: If #5 DIP SWITCH is set to ON to enable the indoor freeze protection and the main board detects the indoor ambient temperature lower than 50°F for 3 minutes successively .

Quitting condition: When indoor ambient temperature rises to 55°F , heating will stop.

4) Temperature Sensor Open Circuit or Short Circuit Protection

If the temperature sensor is an open circuit or a short circuit, the ERROR CODE will display on the digital tube. If the malfunction of temperature sensor is detected for 30 sec, the unit will turn off.

1) 8 DIP Switch Function

OPERATION

Function and Control

(After reprogramming, disconnect the power cord and then power up again to make it effective)

Warning: #2 and #3 should be matched the unit type, but #2 can be switched to OFF to set as Emergency Heat Override! This will cause the E-heater to run all the time.

Advanced Settings

When unit is OFF, press the cool key and fan speed key at the same time for more than 5s. When d0 is displayed, it will enter the advanced parameter setting state;

Press cool key to switch parameter code and parameter value;

Press + or -key to switch parameter code or set parameter value;

ON/OFF key is used to save and exit settings

Code	Function description	Parameter value	Parameter value description
d0	Selection of temperature unit	°F	The unit of temperature is Fahrenheit.
		°C	The unit of temperature is Celsius.
d1	Select of control method	P	The control method is touchpad control.
		r	The control method is universal 24V thermostat control.
d2	Maximum temperature setting	d3 to /90°F	Setting the maximum value is d2, default d2 is 90°F
d3	Minimum temperature setting	60°F ~d2	Setting the minimum value is d3, default d3 is 60°F d2
d4	Indoor temperature calibration	-9 ~9	Recalibration is required after switching temperature unit
d5	Temperature display selection	0~1	1 indicates the indoor sensor temperature; 0 indicates the set temperature

Table 207

OPERATION

System Configuration Fresh Air Vent Control

System Configuration

Fresh Air Vent Control

The vent control lever is located on the left side of the unit, behind the front panel.

NOTE: The vent door shipping hardware must be removed before using the vent control lever. See page 23, Figure 21, (Remove Shipping Screw from Vent Door if present).

When vent door is set to **CLOSE**, only the air inside the room is circulated and filtered. See Figure 25.

When vent door is set to **OPEN**, some outdoor air will be drawn into room. This may reduce heating or cooling efficiency.

Figure 25
Air Vent Control Location

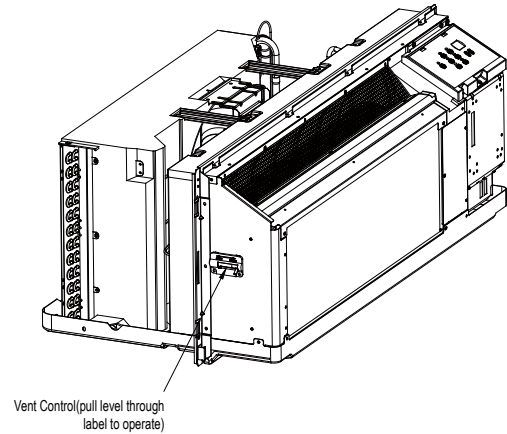

FRP025

Adjusting Air

To adjust air direction:

1. Remove front panel. See Figure 22.
2. Remove louver screws that hold louver insert in place (from back side of front panel. See Figure 26.
3. Turn louver insert and rotate 180°. See Figure 27.
4. Replace louver insert.
5. Replace screws and front panel.

Figure 26
Backside of Front Panel

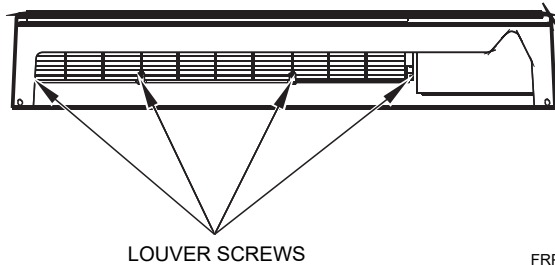

FRP026

Figure 27
Adjusting Louvers

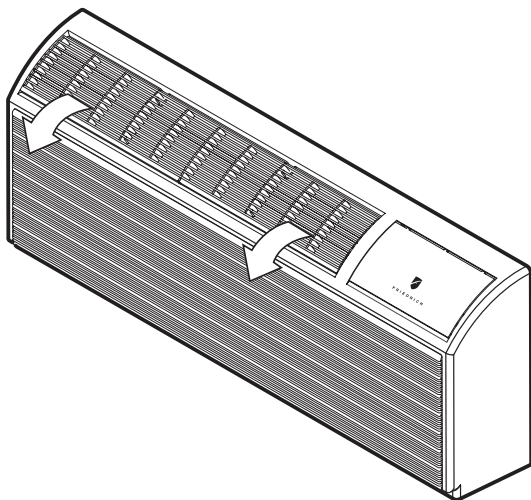

AIR DISCHARGE OUTWARD (Default)

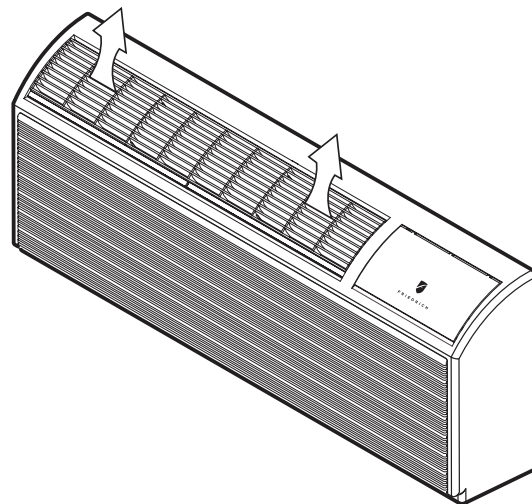

AIR DISCHARGE UPWARD

FRP027

OPERATION

Digital Control User Input Configuration

Digital Control User Input Configuration

The adjustable control dip switches are located at the front portion of the digital Smart Center. The inputs are only visible and accessible with the front cover removed from the PTAC.

Dip Switch Setting

1. Switch 1 - Reserved.
2. Switch 2 - Heat pump enable/disable.
Moving Dip Switch #2 to "OFF" can be set as Emergency Heat Override. In the unlikely event of a compressor failure, a heat pump unit may be switched to operate in only the electric heat mode until repairs can be made.
3. Switch 3 -Electric strip enable/disable.
4. Switch 4 -Heating priority
ON-heat pump to be prior; OFF-Electric heat to be prior.
5. Switch 5 - Room Freeze Protection
Units are shipped from the factory with the room freeze protection enable. Room Freeze Protection can be switched off at the owner' s preference by moving Dip Switch 5 to "OFF" . This feature will monitor the indoor room conditions and in the event that the room falls below 40°F, the unit will automatically run "heating" . This occurs regardless of mode.
6. Switch 6 - Electric memory enable/disable
The factory setting is enabled. The smart center will remember user' s setting. After power cut recovery, the unit will operate the same status as before power cut. Moving Dip Switch 6 to "OFF" will disable this feature, smart center will no more remember settings.
7. Switch 7 - Medium fan speed for indoor fan ON-when press the HIGH fan speed, output the medium speed instead; OFF-output the same speed as selected.
8. Switch 8 - Indoor fan motor rotation speed select ON-7K/9K fan motor rotation speed; OFF-12K/15K fan motor rotation speed;

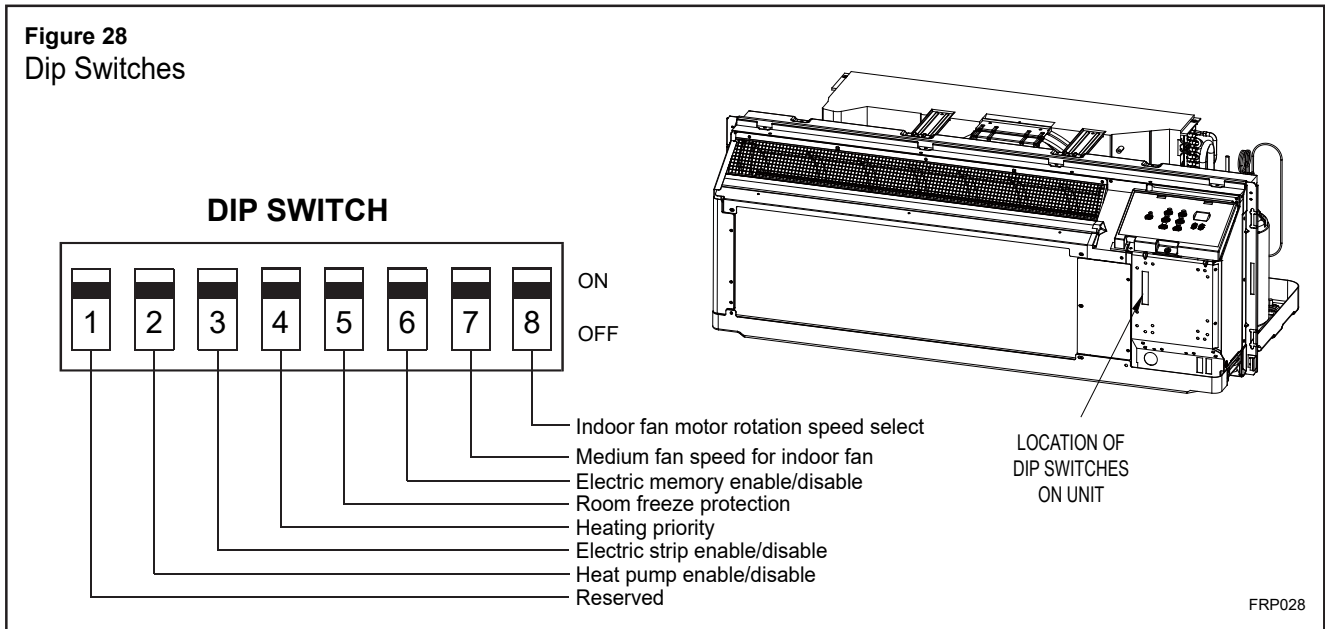

Switch	Description	Function	Factory Setting	Option
#1	Reserved	/	OFF	/
#2	Heat pump	ON-enable heat pump; OFF-disable heat pump, run electric heat only.	HP models-ON Electric heat only-OFF	OFF-Overrides compressor operation(HP modes only)
#3	Electric strip	ON-enable electric heat; OFF-disable electric heat.	ON	Forbidden moving to OFF
#4	Heating priority	ON-Heat pump prior. OFF-Electric heating prior.	OFF	OFF
#5	Room Freeze Protection	ON-Allows the unit to ensure the indoor room temperature does not fall below 40°F even when turned off. OFF-disable freeze protection.	ON	OFF
#6	Electric memory enable/disable	ON-enable; OFF-disable.	ON	OFF
#7	Medium fan speed for indoor fan	ON-when press the HIGH fan speed, output the medium speed instead; OFF-output the same speed as selected.	OFF	Forbidden changing factory setting
#8	Indoor fan motor rotation speed select	ON-7K/9K fan motor rotation speed; OFF-12K/15K fan motor rotation speed.	7K/9K :ON 12K/15K :OFF	Forbidden changing factory setting

OPERATION

Digital Control Operation

Digital Control Panel



FRP029

°F vs °C Display

The unit is factory configured to display all temperatures in degrees Fahrenheit (°F). To switch to degrees Celsius, press the “UP” and “DOWN” buttons simultaneously for three seconds. The display will switch to C degrees. To revert back to °F, press the “UP” and “DOWN” buttons simultaneously for three seconds. The display will switch to F degrees.

Cooling Mode

Pressing the “Cool” button after turn the unit on will put the unit into cooling mode. Press “UP” or “DOWN” button to adjust the set point, the unit will cycle the compressor on and off to maintain a comfortable room. The compressor will cycle on anytime that the room temperature is 2 °F above the set point. The fan will either continuous or cycling, depends on the “Constant Fan” selection. See Constant Fan section.

Heating Mode

After turn on the unit, press the “Heat” button will put the unit into heating mode.

Heat Pump Models(PZH)

When the “Heat” button is pressed initially the unit may call for heat pump or electric strips (depends on different ambient temperature or DIP Switch 4 settings) to bring the room to the set point. When the room temperature falls 2 °F below the set point, the unit will cycle the compressor or electric strip on. The fan will either continuous or cycling, depends on the “Constant Fan” selection. See Constant Fan section. When the outdoor coil temperature falls below 26 °F for 3 minutes, the unit will operate the electric strip instead of heat pump. Only when the room temperature reaches the set point and the outdoor coil temperature rises to 36 °F, the compressor will be allowed to operate again.

Heat/Cool Models(PZE)

After pressing the “Heat” button, adjust the set point and the unit will cycle the electric strip on and off to maintain a comfortable room. The heater will come on anytime that the room temperature is 2 °F below the set point. The fan will either continuous or cycling, depends on the “Constant Fan” selection. See Constant Fan section.

Emergency Heat Operation

In the event of a compressor failure in heat pump mode, the compressor may be locked out to provide heat through the electric strip heater. This feature ensures that even in the unlikely event of a compressor failure, the room temperature can be maintained until the compressor can be serviced. Dip switch 2 controls the emergency heat setting.

Constant Fan

Pressing the “Constant Fan” button will provide constant or cycle fan operation in cooling or heating modes. The fan speed selection is made by pressing either “High” or “Low” or “Auto” fan speed button.

Setting Temperature Limit

Hold “UP” and “High” fan speed buttons at the same time for 5s, digital tube displayer will show R1-R8, default is R8. The temperature(°F) range as below:

- R1: 63-86
- R2: 65-86
- R3: 72-90
- R4: 72-74
- R5: 67-92
- R6: 69-90
- R7: 68-72
- R8: 60-90

OPERATION

Thermostat Installation

Remote Control Thermostat Installation

Install Thermostat

1. Approximately 5 ft from the floor.
2. Close to or in a frequently used room, preferably on an inside wall.
3. On a section of wall without pipes or ductwork.

The Thermostat should NOT be mounted:

1. Close to a window, on an outside wall, or next to a door leading outside.
2. Where it can be exposed to direct sunlight or heat, such as the sun, a lamp, fireplace or any other temperature radiating object which may cause a false reading.
3. Close to or in the direct airflow of supply registers and/or return air grilles.
4. Any areas with poor air circulation, such as a corner, behind a door, or an alcove.

Remote Thermostat and Low Voltage Control Connections

Remote Thermostat

All Friedrich PZ model PTAC units are factory configured to be controlled by either the chassis mounted Smart Center or a 24V remote wall mounted thermostat. The thermostat may be auto or manual changeover as long as the control configuration matches that of the PTAC unit.

NOTE: All PZE models require a single stage cool, single stage heat thermostat. All PZH models require a single stage cool, dual stage heat thermostat with an B reversing valve control. The Friedrich RT6 thermostat can be configured for either model.

To control the unit with a wall mounted thermostat follow the steps below:

1. Unplug the unit before doing any work.
2. Remove the low voltage terminal block from the unit.
3. Remove Fire control cover.
4. Connect the corresponding terminals from the wall thermostat to the terminal block.
5. Plug the terminal block on the unit.
6. Install fireproof cover.
7. Restore power to the unit.
8. Under stand-by mode, press the "Cool" and "UP" buttons simultaneously for three seconds, the digital displays character "r".
9. The unit is now controlled by the wall thermostat only.
10. If the accessory escutcheon kit (PDXRTB) is to be used, install it over the existing control panel.

NOTE: The unit control panel no longer controls the unit. To restore the control panel, press the "Cool" and "UP" buttons simultaneously for three seconds, digital displays character "P".

Thermostat Connections

- R = 24V Power from Unit
- Y = Call for Cooling
- W = Call for Heating
- B = Reversing Valve Energized in Heating. Mode
- GL = Call for Low Fan
- GH = Call for High Fan
- C = Common Ground

*If only one G terminal is present on thermostat connect to GL for low speed fan or to GH for high speed fan operation.

Figure 30
Control board with optional **PDXRTB** escutcheon kit installed



FRP030

OPERATION

Auxiliary Controls

Front Desk Control Terminal

The Friedrich PZ model PTAC has built-in provisions for connection to an external switch to control power to the unit. The switch can be a central desk control system.

For front desk control operation, connect one side of the normal open switch to the R terminal and the other to the FD terminal.

The control logic as below:

(a). Turn ON unit: short R and FD then release for one time within 5s.

(b). Turn OFF unit: short R and FD then release for twice within 5s.

(c). Force unit shut down for one time: short R and FD short over 5s.



NOTE: After forced shut down, you can turn on the unit again by control panel.

NOTE: The desk control system and switches must be field supplied.

Energy Management

Sometimes known as Front Desk Control, an input is provided so that the unit can be manually disabled from a remote location. If the unit detects 24Vac on this input, it will automatically turn itself off. If no voltage is detected on the input, the unit will run normally.

NOTE: It is the installer's responsibility to ensure that all control wiring connections are made in accordance with the installation instructions. Improper connection of the thermostat control wiring and/or tampering with the unit's internal wiring can void the equipment warranty. Other manufacturer's PTACs and even older Friedrich models may have different control wire connections. Questions concerning proper connections to the unit should be directed to Friedrich.

 WARNING	
	<p>Electrical Shock Hazard</p> <p>Turn off electrical power before service or installation.</p> <p>ALL electrical connections and wiring MUST be installed by a qualified electrician and conform to the National Code and all local codes which have jurisdiction.</p> <p>Improper connection of the thermostat control wiring and/or tampering with the units internal wiring may result in property damage, personal injury or death.</p>

OPERATION

General Knowledge Sequence Of Refrigeration

A good understanding of the basic operation of the refrigeration system is essential for the service technician. Without this understanding, accurate troubleshooting of refrigeration system problems will be more difficult and time consuming, if not (in some cases) entirely impossible. The refrigeration system uses four basic principles in its operation which are as follows:

1. "Heat always flows from a warmer body to a cooler body."
2. "Heat must be added to or removed from a substance before a change in state can occur"
3. "Flow is always from a higher pressure area to a lower pressure area."
4. "The temperature at which a liquid or gas changes state is dependent upon the pressure."

The refrigeration cycle begins at the compressor when a demand is received from the thermostat or control panel. Starting the compressor creates a low pressure in the suction line which draws refrigerant gas (vapor) into the compressor. The compressor then "compresses" this refrigerant vapor, creating a super-heated state.

The refrigerant leaves the compressor through the discharge line as a hot high pressure gas (vapor). The refrigerant enters the condenser coil where it gives up some of its heat. The condenser fan moving air across the coil's finned surface facilitates the transfer of heat from the refrigerant to the relatively cooler outdoor air.

When a sufficient quantity of heat has been removed from the refrigerant gas (vapor), the refrigerant will "condense" (i.e. change to a liquid). Once the refrigerant has been condensed (changed) to a liquid it is sub-cooled by the air that continues to flow across the condenser coil.

The design determines at exactly what point (in the condenser) the change of state (i.e. gas to a liquid) takes place. In all cases, however, the refrigerant must be totally condensed (changed) to a liquid before leaving the condenser coil.

The refrigerant leaves the condenser coil through the liquid line as a high pressure high temperature liquid.

The liquid refrigerant next enters the metering device. The metering device is called a capillary tube. The purpose of the metering device is to "meter" (i.e. control or measure) the quantity of refrigerant entering the evaporator coil.

In the case of the capillary tube this is accomplished (by design) through size (and length) of device, and the pressure difference present across the device. Since the evaporator coil is under a lower pressure (due to the suction created by the compressor) than the liquid line, the liquid refrigerant leaves the metering device entering the evaporator coil. As it enters the evaporator coil, the larger area and lower pressure allows the refrigerant to expand and lower its temperature (heat intensity). This expansion is often referred to as "boiling" or atomizing. Since the unit's blower is moving indoor air across the finned surface of the evaporator coil, the expanding refrigerant absorbs some of that heat. This results in a lowering of the indoor air temperature, or cooling.

As it enters the evaporator coil, the larger area and lower pressure allows the refrigerant to expand and lower its temperature (heat intensity). This expansion is often referred to as "boiling" or atomizing. Since the unit's blower is moving indoor air across the finned surface of the evaporator coil, the expanding refrigerant absorbs some of that heat. This results in a lowering of the indoor air temperature, or cooling.

The expansion and absorbing of heat cause the liquid refrigerant to evaporate (i.e. change to a gas). Once the refrigerant has been evaporated (changed to a gas), it is superheated by the air that continues to flow across the evaporator coil.

The particular system design determines at exactly what point (in the evaporator) the change of state (i.e. liquid to a gas) takes place. In all cases, however, the refrigerant must be totally evaporated (changed) to a gas before leaving the evaporator coil.

The low pressure (suction) created by the compressor causes the refrigerant to leave the evaporator through the suction line as a superheated vapor. The refrigerant then returns to the compressor, where the cycle is repeated.

OPERATION

Refrigerant System Diagram

(1) Cooling + Heat Pump + Auxiliary Electric Heater

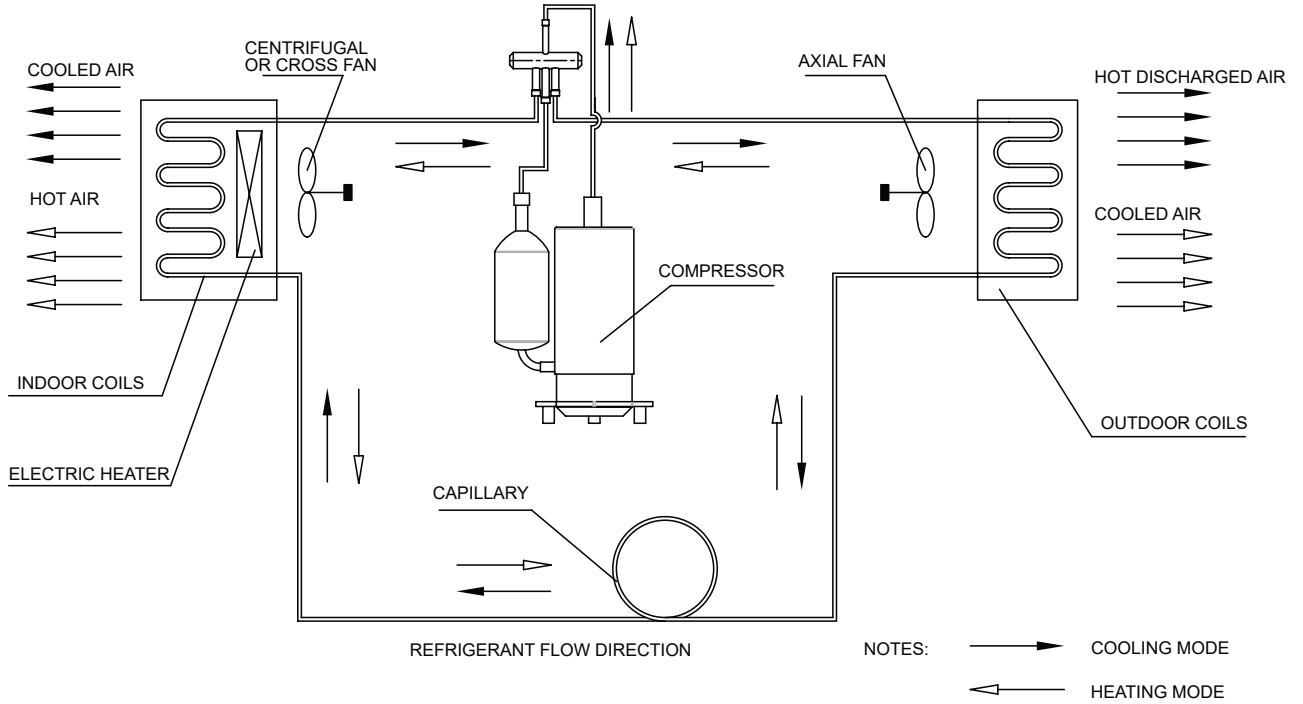

(2) Cooling + Electric Heater

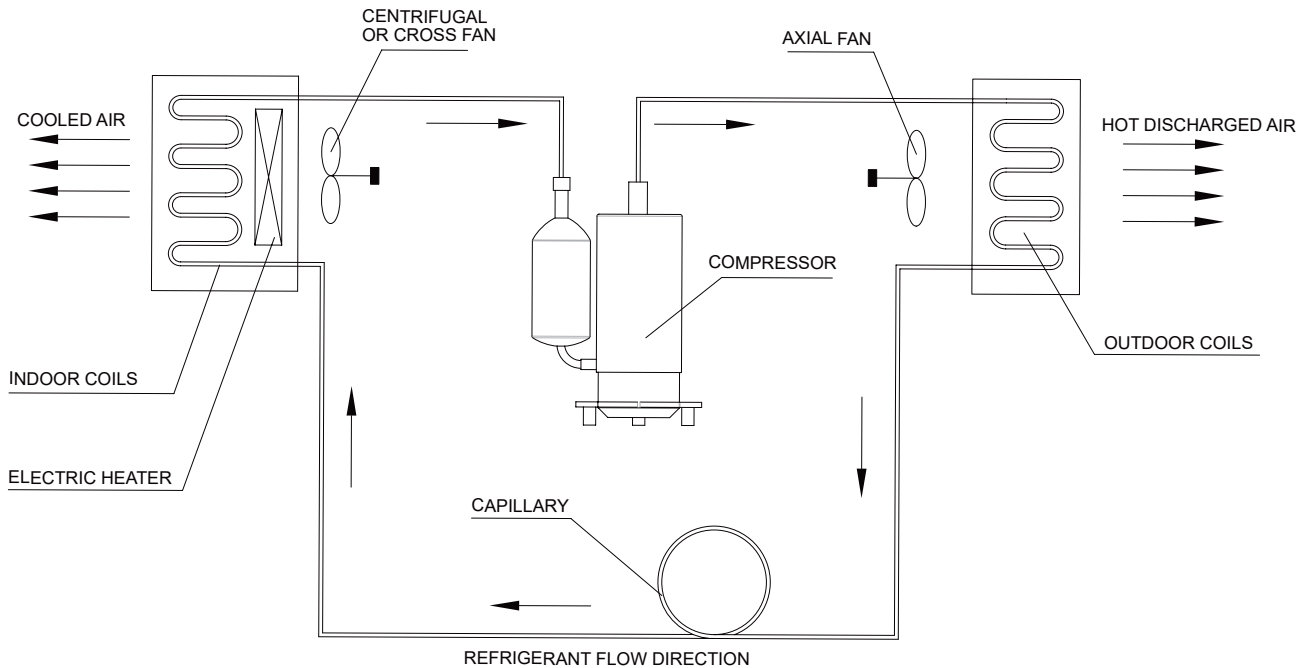

Figure 301 (Sequence of Operation)

TROUBLESHOOTING

Table 501

Error code and solutions

ERROR CODE	Meaning	Problem	Solutions
E2	Room Temp. Sensor Failure	T1 - room temp sensor open or shorted circuit	Refer to Thermistor checks
E3	Evaporator Coil Temp Sensor Failure	T2 - evaporator coil temp sensor open or shorted circuit	Refer to Thermistor checks
E4	Air blow out over heat in electric heat mode	1. Indoor air filter dirty 2. Obstructions in air air intake	Refer to E.4 error code Troubleshooting
E5	Condenser coil temp sensor Failure	T3 - condenser coil temp sensor.	Refer to Thermistor checks
E7	Outdoor ambient temp sensor Failure	T4 - outdoor ambient temp sensor.	Refer to Thermistor checks
E8	Overheating protection/defrosting	1. Dirty air filter. 2. Indoor fan failure. 3. Evaporator coil temp sensor failure 4. Refrigeration system failure.	Refer to E.8 error code Troubleshooting
E9	High Temp Protection	1. Poor Outdoor airflow 2. Outdoor fan failure. 3. Condenser coil temp sensor failure. 3. Refrigeration system failure.	Refer to E.9 error code Troubleshooting
EE	EEprom Failure	EEprom Failure	Replace Main PCB
F6	Indoor Fan feedback Error	Indoor Fan is locked up, wiring is loose, or motor is faulty	1. Check to make sure that blower wheel spins freely. 2. Check indoor fan motor circuit. 3. Replace Main PCB
F8	Indoor fan feedback error	Indoor Fan is locked by something or communication cable is loose must power cycle to reset	1. Power cycle unit 2. Check to make sure that blower wheel spins freely. 3. Check indoor fan motor circuit. 4. Replace Main PCB.

TROUBLESHOOTING

Unit Lost Power

1. Make sure the wiring is adequate for your unit.

Warning: DO NOT use an extension cord.

2. Make sure that the receptacle is compatible with the air conditioner cord plug provided.

3. Test the power cord.

Refer to the [Electrical Data](#) page to find power requirements, receptacle size, and test for power cord.



Figure 502

TROUBLESHOOTING

Control Panel Does Not Work

If the power supply is normal, but the control panel does not work, maybe the 24 V thermostat is in control. Check the thermostat;

In standby mode, simultaneously press the [HEAT] key and the [+] key on the operation panel for 5 seconds or the [COOL] and [+] keys for 5 seconds to switch between them;

When the 24V thermostat is controlled, the LED display shows "r" and the buzzer sounds twice; when the control panel is controlled, it displays "p" and the buzzer sounds once;

If the LED displays "P" , and the panel has some strange character deviation display, the internal PCB is broken, replace it. Refer to [Operation Panel removal](#).



Figure 503

TROUBLESHOOTING

Malfunction of Temperature Sensor

E2/E3/E4/E5

1. Remove Power from Unit.
2. [Remove front Panel.](#)
3. [Open electrical Control Box.](#)
4. Using a multi meter ohm across applicable pins for the sensor you are checking.
5. Refer to thermistor charts in Appendix for resistance and temperature deviation.

E2 Error 5k Room Temp. Sensor (T1).

E3 Error 5k Evaporator Coil Temp Sensor (T2).

E5 Error 5k Condenser coil temp sensor (T3).

E7 Error 5k Outdoor ambient temp sensor (T4).

6. Replace sensor if open or if resistance values deviate by more than 10% of the listed values.

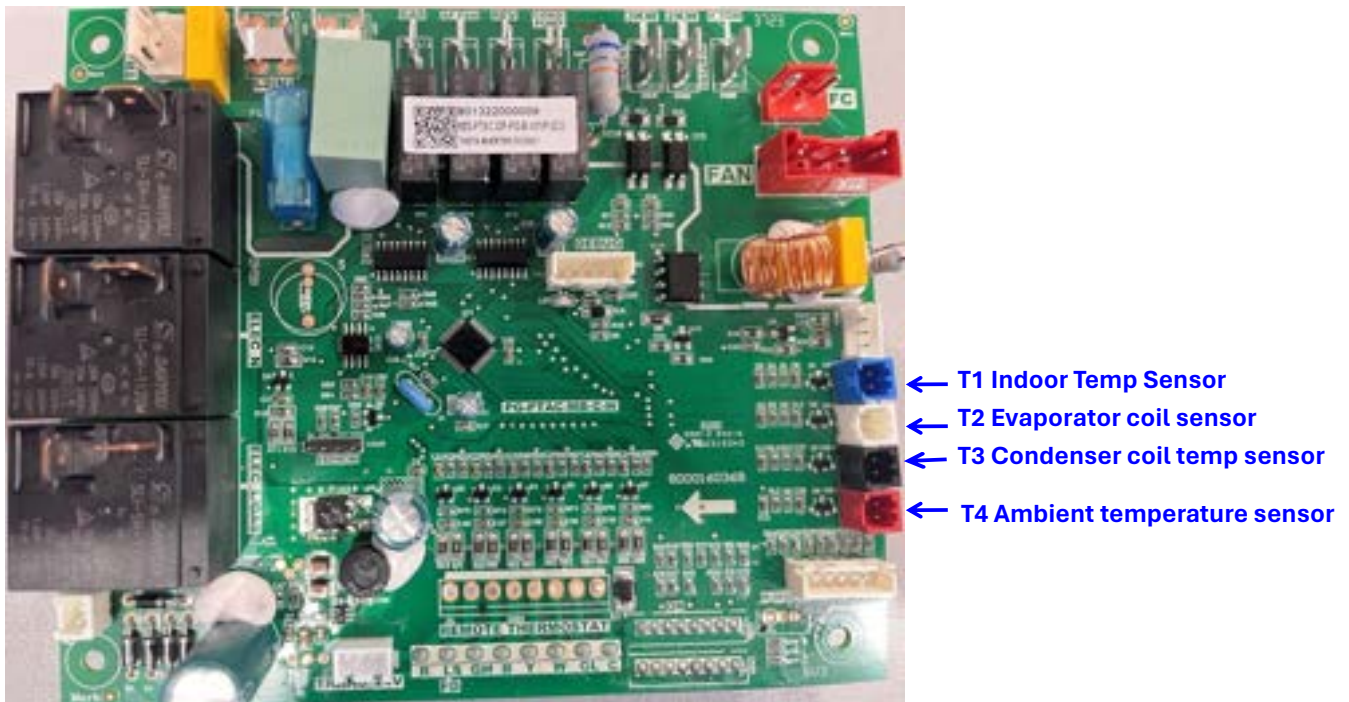
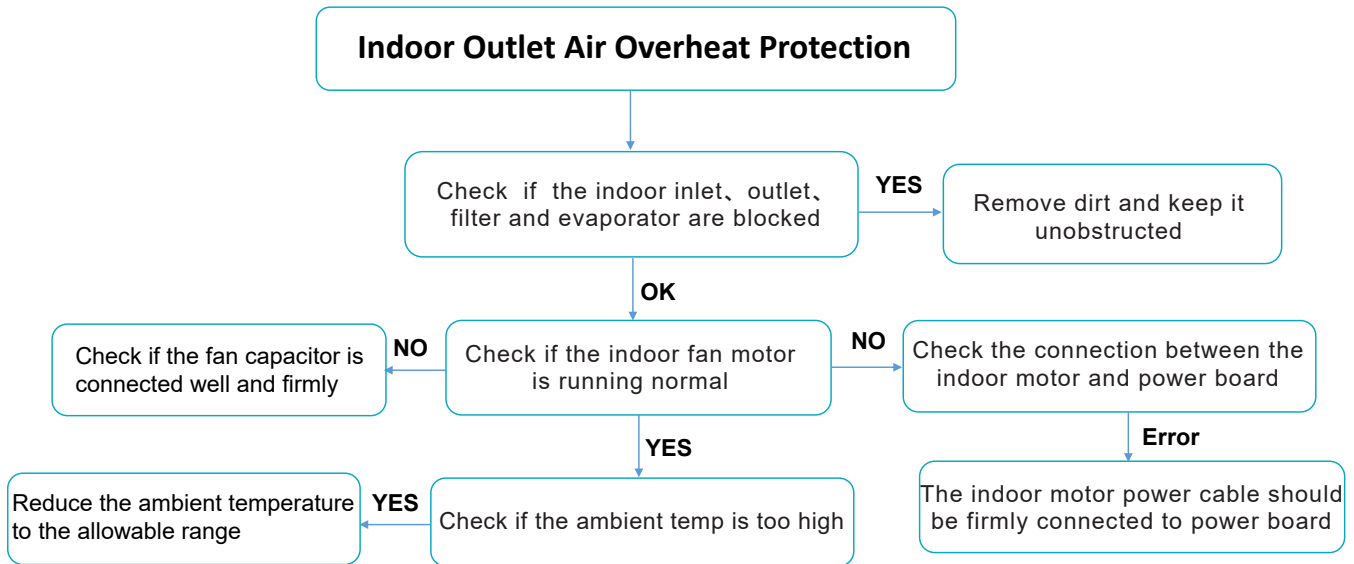

Figure 504

TROUBLESHOOTING

E4 Function Error

Error code: **E4: Indoor Outlet Air Overheat Protection in Electric heating mode**



E4 protection logic: electric heating 3.6KW/5KW

When $T_4 > 150^\circ\text{F}$ the fan will switch to high speed.

At this time, such as $T_4 \geq 154^\circ\text{F}$, turn off the electric heating. The fan runs high speed; When the electric heating is turned off for one minute and $T_4 \leq 115^\circ\text{F}$ is detected and the operating speed of the fan returns to the set speed.

If $T_4 \geq 154^\circ\text{F}$ is detected three times within 30 minutes, E4 fault is reported and power down is required to recover.



Figure 505

TROUBLESHOOTING

E8 Function Error

Error code: **E8**: Cooling/Heat Pump Overload, Outdoor/Indoor Coil Overheat

Cooling/Heat Pump Overload, Outdoor/Indoor Coil Overheat

- ◆ Make sure the indoor and outdoor grilles are not blocked ;
- ◆ Make sure the indoor fan and outdoor fan are both working well ;
- ◆ Clean the air filter, indoor coil and outdoor coil as necessary.

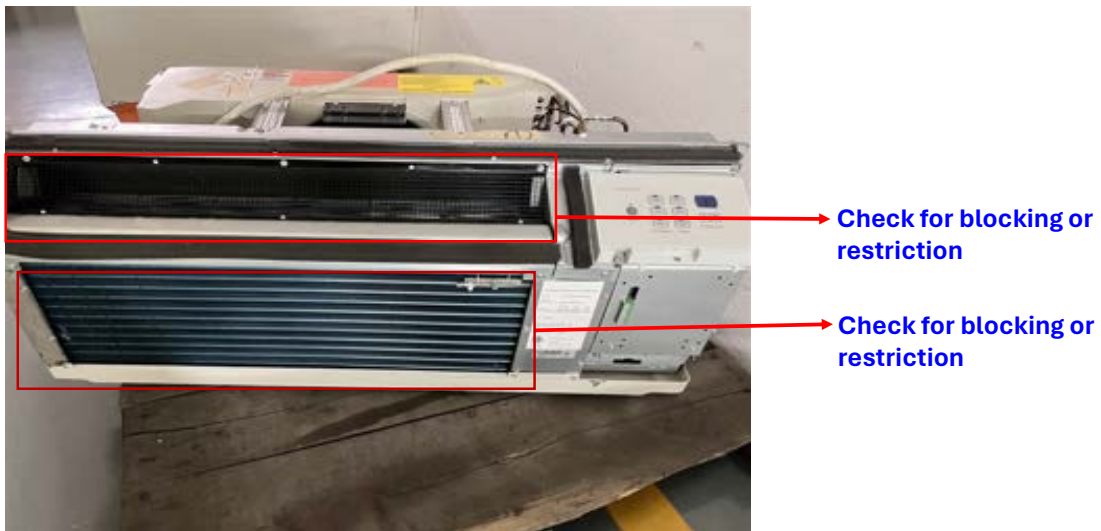

Figure 506

TROUBLESHOOTING

E9 Function Error

Error code: E9: T3 high temperature protection

Reasons and solutions:

1. Outdoor air circulation is bad. Check if any obstacle blocks the air circulation.
2. Condenser is too dirty. Wash the condenser.



Figure 507

3. Unit installation error. If the wall sleeve is too wide, the condenser can not exchange air well with the ambient air. Correct the installation. Refer to the Installation/ Operation manual.

4. Outdoor fan is not running or running speed is too low. Check the fan. The fan blade should be rotated smoothly and the wiring is not loose.



Figure 508

5. Outdoor Ambient temperature is too high. Increase the set point (this will get more cycles of compressor and let the condenser cool down. This may help avoid E9 error.

6. Condenser coil temperature sensor broken. Check thermistor. Refer to:

7. Replace PCB

8. Check refrigerant system for low charge or restriction. Refer to:

TROUBLESHOOTING

Electric Heater Not Running

1. Indoor unit air circulation is blocked. Remove the obstacle.
2. DIP switch of NO.3 is in OFF position. Set it to ON position.

3. Remove power from the unit.
4. [Remove front panel](#) (refer to to figure 701).
5. [Open electrical control box](#) (refer to figures 702 thru 705).
6. Restore power to unit.
7. Place a demand on he electric heater. Refer to the operation section.
8. Check Voltage

Check for voltage at output terminals on heater relays. If 230/ supply voltage is present and heater element does not operate correctly, replace heater assembly. If 230/265 volts in not present, check power at heater relay input terminals..

9. Two limit switches are incorporated into the heater assembly. The primary opens at 160°F and closes at 130°F. The secondary's open temp is 221°F. They can not be replaced independently. If they are found to be faulty the entire heater assembly must be replaced as a unit.

- a. Thermostat on the heater is cut out. Wait for awhile to see if it can restart.

- b. Thermal fuse is broken. Replace heater. Check resistance (open reading).

10. Check Heater Coil

- a. Testing of the elements can be made with an ohmmeter across the terminals after the 2 heater wires have been disconnected. Readings should always been taken when coil is cold.

- b. Reconnect wires and operate heat to place electric heater in demand- See sequence of operation for details.

11. Wiring error. Check wiring with the circuit diagram.

Heater relay
Output terminals

Heater relay
Input terminals

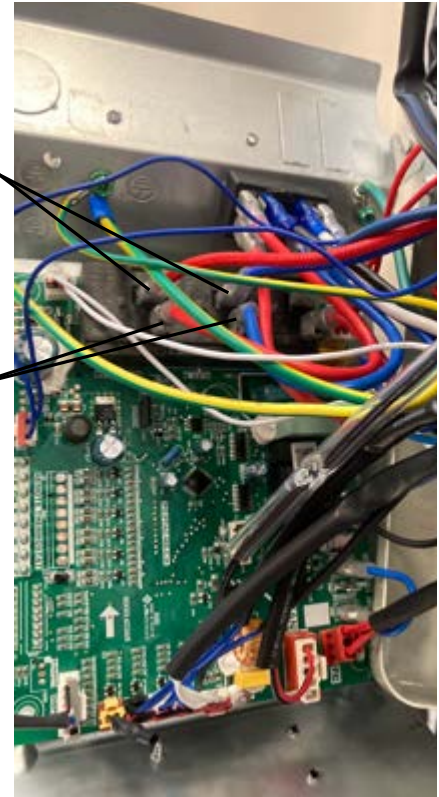

Figure 509



Heater Coil

Heater Wire
Terminals

Limit switches

Figure 510

COMPONENT TESTING

Check Indoor Fan Motor

⚠ WARNING	
	RISK OF ELECTRIC SHOCK Unplug and/or disconnect all electrical power to the unit before performing inspections, maintenances or service.
	Failure to do so could result in electric shock, serious injury or death.

1. Remove power from unit.
2. Remove Front Panel. ([Refer to Chassis Removal](#))([Figure 701](#))
3. [Open electrical box](#) (Refer to figures 702 thru 705).
4. Apply power to unit.
5. Check voltage at Indoor motor control connector.
 - a. White to ground VAC (Should read Supply line Voltage).
 - b. If No voltage is present [replace PCB](#) (refer to figure 706).
 - c. If only partial voltage is present ;
Check voltage from black to ground should = 1/2 the supply voltage.
 - d. If no voltage then fan motor internal overheat limit switch [100°C (212°F)] has opened. (If motor is cool to touch- [replace motor](#)), if hot proceed to next check.
 - e. Check red to ground should = 1/2 supply voltage.
If no voltage present;
6. [Check indoor fan motor capacitor](#).
If capacitor checks good;
7. Check fan motor windings resistance;
 - a. Remove power from unit.
 - b. Disconnect indoor motor control connector.
 - c. Check resistance
Red to white = (red to black) +(black to white).
[Replace motor](#) if windings check bad.

Indoor Motor Control Connector

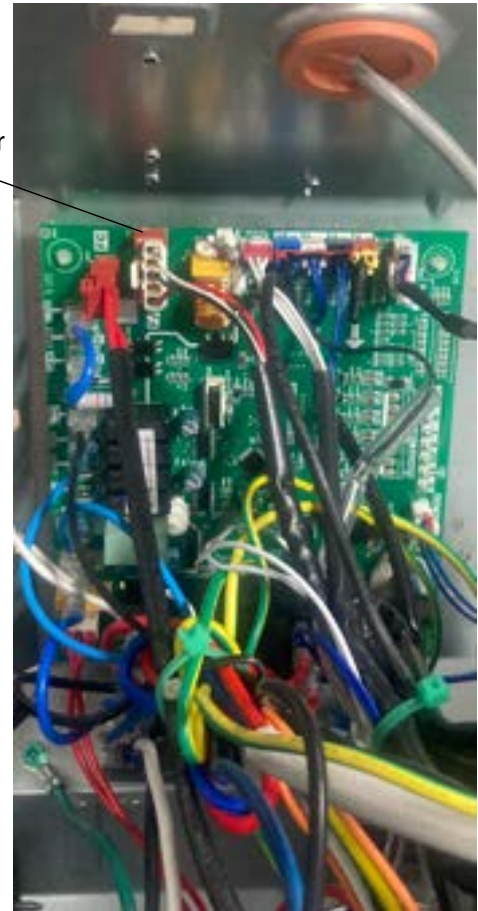

Figure 511



Figure 512

COMPONENT TESTING

Check Outdoor Fan Motor

1.

⚠ WARNING	
	RISK OF ELECTRIC SHOCK Unplug and/or disconnect all electrical power to the unit before performing inspections, maintenances or service.
	Failure to do so could result in electric shock, serious injury or death.

Remove power from unit.

2. Remove Front Panel. ([Refer to Chassis Removal](#))([Figure 701](#))
3. [Open electrical box](#) (Refer to figures 702 thru 705).
4. Apply power to unit.
5. Check voltage at Outdoor motor control terminals.
 - a. White (L2) to Black (Condump) VAC (Should read Supply line Voltage).
 - b. If No voltage is present [replace PCB](#) (refer to figure 706).
6. [Check outdoor fan capacitor](#) (CP2)
If capacitor checks good;
7. Check fan motor windings resistance;
 - a. Remove power from unit.
 - b. Disconnect wires from main pcb and capacitor
 - c. Check resistance
Resistance values across legs should be similar.
[Replace motor](#) if windings check bad.

cond/pump terminal

L2

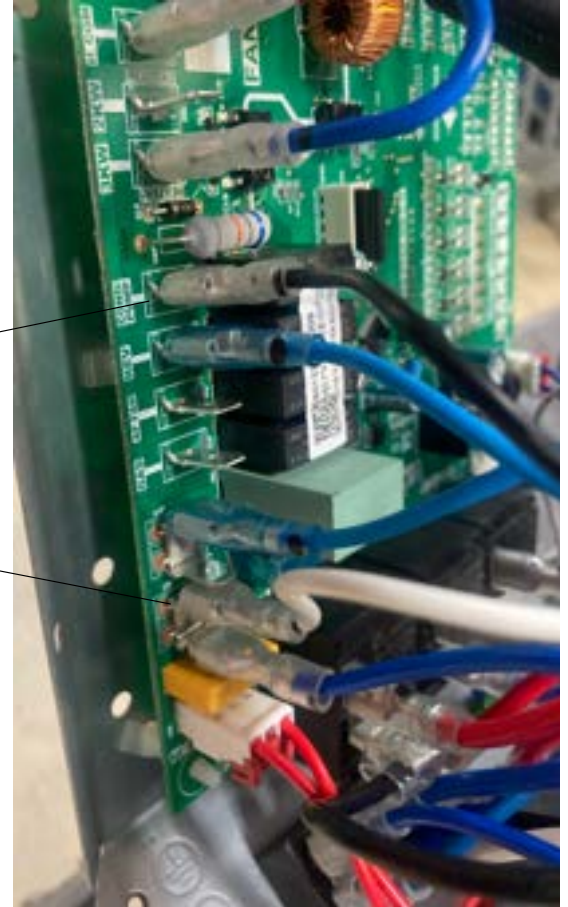
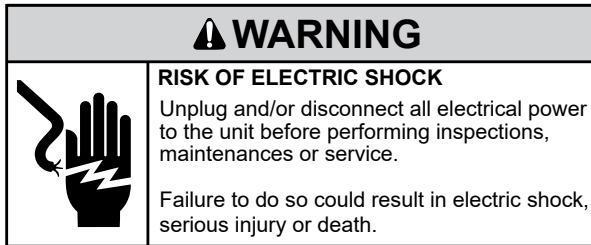

Figure 513

COMPONENT TESTING

Check Fan Motor Capacitors

1. Remove power from the unit.
2. [Open electrical Control Box.](#)



NOTE: Many motor capacitors are internally fused. Shorting the terminals will blow the fuse, ruining the capacitor. A 20,000 ohm 2 watt resistor can be used to discharge capacitors safely. Remove wires from capacitor and place resistor across terminals.

1. Disconnect leads to capacitor that you are checking.
2. Bleed down capacitor with 2 watt resistor.
3. Set multi-meter to diode check setting.
4. Check Resistance across capacitor terminals by placing the red lead on the run terminal and the black lead on the common terminal. (The meter will send a small charge into the capacitor)
5. The meter should show a certain amount of resistance initially and then increase in resistance as the charge in the capacitor dissipates until infinity is reached.
6. If the meter shows continuity, or does not bleed back down to infinity, the capacitor is shorted and should be replaced.
7. If the meter initially shows infinity the capacitor is open and should be replaced.

Check Capacitance values in micro Farads using capacitor analyzer.

1. Indoor fan capacitor should read 1.5 uf.
2. Outdoor fan capacitor should read 3.0 uf.

COMPONENT TESTING

Main PCB Board Connector Identification

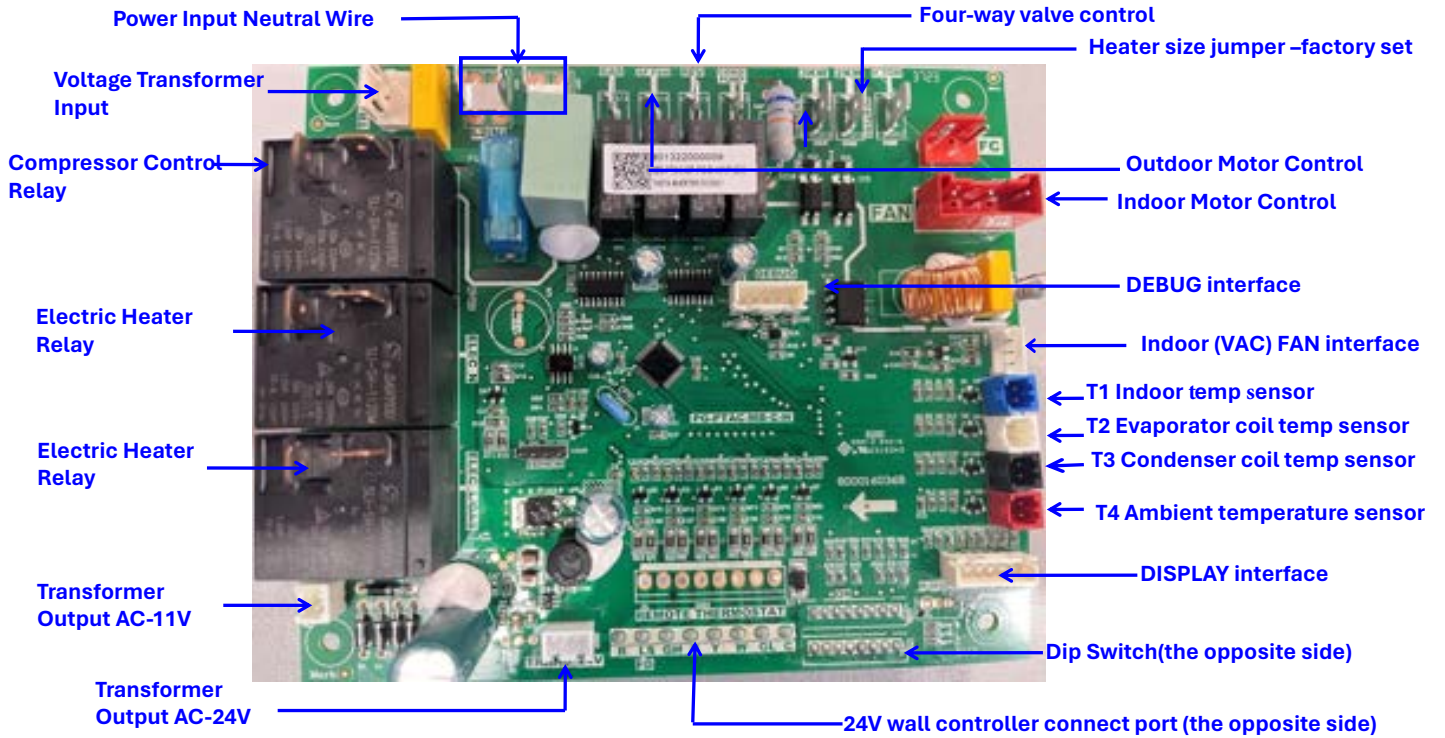

Figure 709 (Main PCB (logic) Board)

COMPONENT TESTING

Reversing Valve

A reversing valve is a component of a heat pump that changes the direction of refrigerant flow, allowing the system to function in both heating and cooling modes.

It consists of a pressure-operated, main valve and a pilot valve actuated by a solenoid plunger. The solenoid is energized during the heating cycle only.

The single tube on one side of the main valve body is the high-pressure inlet to the valve from the compressor. The center tube on the opposite side is connected to the low pressure (suction) side of the system. The other two are connected to the indoor and outdoor coils. Small capillary tubes connect each end of the main valve cylinder to the "A" and "B" ports of the pilot valve. A third capillary is a common return line from these ports to the suction tube on the main valve body. Four-way reversing valves also have a capillary tube from the compressor discharge tube to the pilot valve.

The plunger assembly in the main valve can only be shifted by the pressure differential between the high and low sides of the system. The pilot section of the valve opens and closes ports for the small capillary tubes to the main valve to cause it to shift.

Checking the Reversing Valve

NOTE: System operating pressures must be near normal before valve can shift. NOTE: You must have normal operating pressures before the reversing valve can shift.

Run the unit in the heating mode then disconnect one of the at the reversing valve and the valve should shift to cooling mode. If valve does not shift - replace the valve (verify the unit is properly charged before replacing valve.) For a stuck valve diagnosis run in the cooling mode and check the temp difference between the suction line from the evaporator and the common suction line at the compressor, if there is more than a 3 °F difference then change the valve.

Checking The Reversing Valve Solenoid

The solenoid coil is an electromagnetic type coil mounted on the reversing valve and is energized during the operation of the compressor in the heating cycle.

1. Turn off high voltage electrical power to unit.
2. Unplug line voltage lead from reversing valve coil.
3. Check for electrical resistance through the coil. If the coil is open replace the coil.
4. Check from each lead of coil to the copper liquid line as it leaves the unit or the ground lug. There should be no continuity between either of the coil leads and ground; if there is, coil is grounded and must be replaced.
5. If coil tests okay, reconnect the electrical leads.
6. Make sure coil has been assembled correctly.

NOTE: Do not start unit with solenoid coil removed from valve, or do not remove coil after unit is in operation. This will cause the coil to burn out.

⚠ WARNING	
	<p>ELECTRIC SHOCK HAZARD</p> <p>Disconnect power to the unit before servicing. Failure to follow this warning could result in serious injury or death.</p>

⚠ WARNING	
	<p>HIGH PRESSURE HAZARD</p> <p>Sealed Refrigeration System contains refrigerant and oil under high pressure.</p> <p>Proper safety procedures must be followed, and proper protective clothing must be worn when working with refrigerants.</p> <p>Failure to follow these procedures could result in serious injury or death.</p>

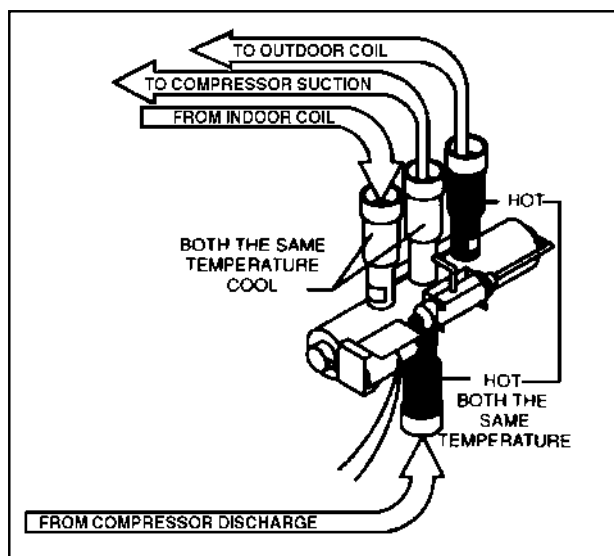
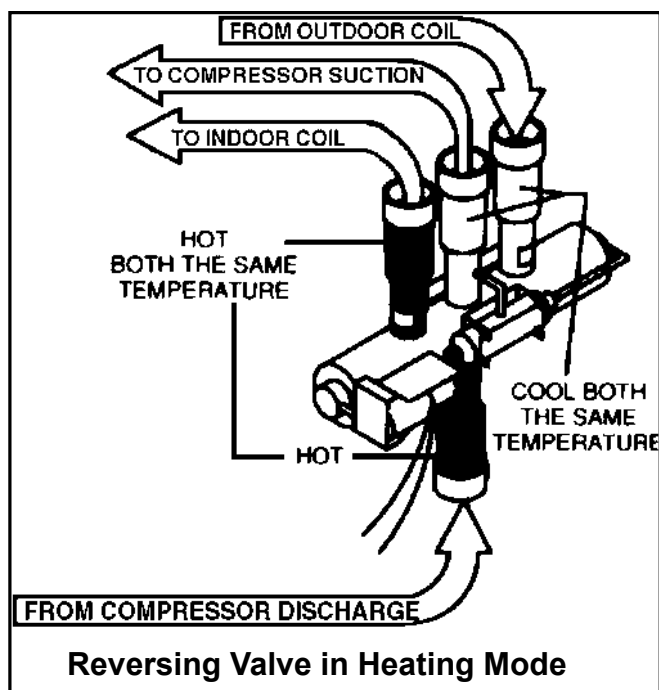

COMPONENT TESTING

Compressor Checks

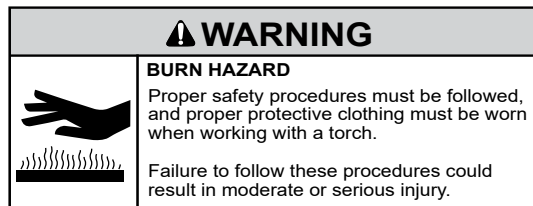
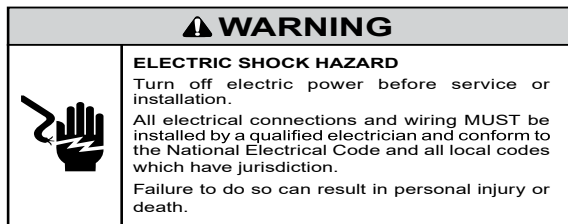

Locked Rotor Voltage (L.R.V.) Test

Locked rotor voltage (L.R.V.) is the actual voltage available at the compressor under a stalled condition.

Single Phase Connections

Disconnect power from unit. Using a voltmeter, attach one lead of the meter to the run "R" terminal on the compressor and the other lead to the common "C" terminal of the compressor. Restore power to unit.

Determine L.R.V.

Start the compressor with the volt meter attached; then stop the unit. Attempt to restart the compressor within a couple of seconds and immediately read the voltage on the meter. The compressor under these conditions will not start and will usually kick out on overload within a few seconds since the pressures in the system will not have had time to equalize. Voltage should be at or above minimum voltage of 197 VAC, as specified on the rating plate. If less than minimum, check for cause of inadequate power supply; i.e., incorrect wire size, loose electrical connections, etc.

Amperage (R.L.A) Test

The running amperage of the compressor is the most important of these readings. A running amperage higher than that indicated in the performance data indicates that a problem exists mechanically or electrically.

Single Phase Running and L.R.A. Test

NOTE: Consult the specification and performance section for running amperage. The L.R.A. can also be found on the rating plate.

Select the proper amperage scale and clamp the meter probe around the wire to the "C" terminal of the compressor.

Turn on the unit and read the running amperage on the meter. If the compressor does not start, the reading will indicate the locked rotor amperage (L.R.A.).

Overloads

The compressor is equipped with either an external or internal overload which senses both motor amperage and winding temperature. High motor temperature or amperage heats the overload causing it to open, breaking the common circuit within the compressor. Heat generated within the compressor shell, usually due to recycling of the motor, is slow to dissipate. It may take anywhere from a few minutes to several hours for the overload to reset.

Checking the Overloads

External Overloads

With power off, remove the leads from compressor terminals. If the compressor is hot, allow the overload to cool before starting check. Using an ohmmeter, test continuity across the terminals of the external overload. If you do not have continuity; this indicates that the overload is open and must be replaced.

Internal Overloads

The overload is embedded in the motor windings to sense the winding temperature and/or current draw. The overload is connected in series with the common motor terminal.

Should the internal temperature and/or current draw become excessive, the contacts in the overload will open, turning off the compressor. The overload will automatically reset, but may require several hours before the heat is dissipated.

NOTE: The overload will automatically reset, but may require several hours before the heat is dissipated. Ensure that compressor overload switch has been rechecked after it cools down, before replacing compressor.

Checking the Internal Overload

1. With no power to unit, remove the leads from the compressor terminals.
2. Using an ohmmeter, test continuity between terminals C-S and C-R. If no continuity, the compressor overload is open and the compressor must be replaced.

COMPONENT TESTING

Compressor Checks

⚠ WARNING	
	ELECTRIC SHOCK HAZARD Turn off electric power before service or installation. Extreme care must be used, if it becomes necessary to work on equipment with power applied.
	Failure to do so could result in serious injury or death.

⚠ WARNING	
	HIGH PRESSURE HAZARD Sealed Refrigeration System contains refrigerant and oil under high pressure.
	Proper safety procedures must be followed, and proper protective clothing must be worn when working with refrigerants. Failure to follow these procedures could result in serious injury or death.

Single Phase Resistance Test

Remove the leads from the compressor terminals and set the ohmmeter on the lowest scale (R x 1).

Touch the leads of the ohmmeter from terminals common to start ("C" to "S"). Next, touch the leads of the ohmmeter from terminals common to run ("C" to "R").

Add values "C" to "S" and "C" to "R" together and check resistance from start to run terminals ("S" to "R"). Resistance "S" to "R" should equal the total of "C" to "S" and "C" to "R."

In a single phase PSC compressor motor, the highest value will be from the start to the run connections ("S" to "R"). The next highest resistance is from the start to the common connections ("S" to "C"). The lowest resistance is from the run to common. ("C" to "R") Before replacing a compressor, check to be sure it is defective.

GROUND TEST

Ensure that compressor wires are disconnected. Use an ohmmeter set on its highest scale. Touch one lead to the copper tubing (clean point of contact as a good connection is a must) and the other probe in turn to each compressor terminal. If a reading is obtained the compressor is grounded and must be replaced.

Check the complete electrical system to the compressor and compressor internal electrical system, check to be certain that compressor is not out on internal overload.

Complete evaluation of the system must be made whenever you suspect the compressor is defective. If the compressor has been operating for sometime, a careful examination must be made to determine why the compressor failed.

Many compressor failures are caused by the following conditions:

1. Improper air flow over the evaporator.
2. Overcharged refrigerant system causing liquid to be returned to the compressor.
3. Restricted refrigerant system.
4. Lack of lubrication.
5. Liquid refrigerant returning to compressor causing oil to be washed out of bearings.
6. Non-condensables such as air and moisture in the system. Moisture is extremely destructive to a refrigerant system.
7. Run Capacitor.

CHECKING COMPRESSOR EFFICIENCY

The reason for compressor inefficiency is normally due to broken or damaged suction and/or discharge valves, reducing the ability of the compressor to pump refrigerant gas.

NOTE: Before installing valves and gauges, check the compressor discharge temperature and compressor current, Low compressor amperage combined with low discharge temperature is an indication that the compressor might be faulty,

This condition can be checked as follows:

1. Install a piercing valve on the suction and discharge or liquid process tube.
2. Attach gauges to the high and low sides of the system.-
3. Start the system and run a "cooling or heating performance test." If test shows:
 - A. Below normal high side pressure
 - B. Above normal low side pressure
 - C. Low temperature difference across coil

The compressor valves are faulty - replace the compressor.

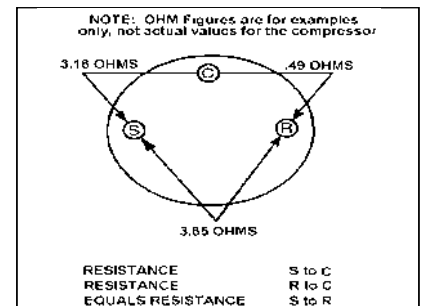



Figure 705 (Resistance Chart)

UNIT DISASSEMBLY AND COMPONENT REPLACEMENT

Remove Chassis

⚠ WARNING	
	ELECTRIC SHOCK HAZARD Turn off electric power before service or installation. Extreme care must be used, if it becomes necessary to work on equipment with power applied. Failure to do so could result in serious injury or death.

The Front Panel needs to be removed prior to any repair or troubleshooting procedures.

1. Front panel is removed by lifting up and rotating back and down.

⚠ CAUTION
Unit weighs approximately 120 pounds. Use caution when removing to prevent personal injury or damage to the equipment.

2. Remove 4 mounting screws and slide unit out of sleeve.



Figure 701 (Chassis Removal)

UNIT DISASSEMBLY AND COMPONENT REPLACEMENT

Remove Operation panel

⚠ WARNING	
	ELECTRIC SHOCK HAZARD
	Turn off electric power before service or installation. Extreme care must be used, if it becomes necessary to work on equipment with power applied.
	Failure to do so could result in serious injury or death.

1. Remove Front Panel. ([Refer to Chassis Removal](#))

Remove 1 screw securing User Interface to the control box. (Figure 702)



Figure 702 (Operation Panel Removal)

2. Remove 7 screws attaching display board to user interface. (Figure 703)

3. Disconnect plug. (Figure 703)

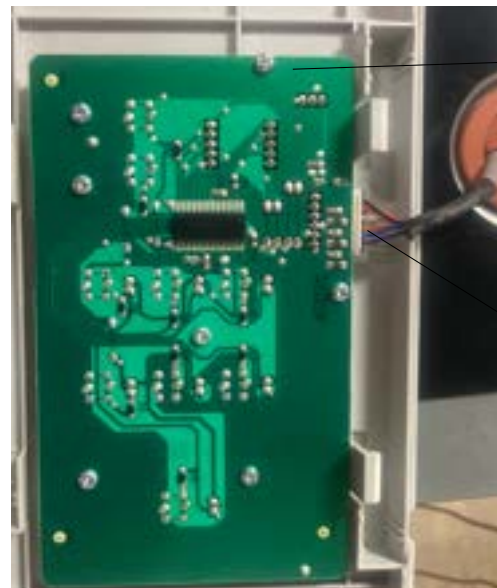



Figure 703 (Operation Panel Removal)

UNIT DISASSEMBLY AND COMPONENT REPLACEMENT

Open Electrical Control Box

⚠ WARNING	
	ELECTRIC SHOCK HAZARD
	Turn off electric power before service or installation. Extreme care must be used, if it becomes necessary to work on equipment with power applied.
	Failure to do so could result in serious injury or death.

1. [Remove front panel.](#) (Figure 701).
2. [Remove Operation Panel](#)(Figures 702 thru 703).
3. Remove 7 screws.(Figure 704)
4. Unhinge electrical box. (Figure 705)



Remove 7 Screws

Figure 704 (Open Electrical Box)



Hinge

Figure 705 (Open Electrical Box)

UNIT DISASSEMBLY AND COMPONENT REPLACEMENT

Remove Main PCB (logic) Board

⚠ WARNING	
	<p>ELECTRIC SHOCK HAZARD Turn off electric power before service or installation. Extreme care must be used, if it becomes necessary to work on equipment with power applied.</p> <p>Failure to do so could result in serious injury or death.</p>

1. [Remove front panel.](#) (Figure 701).
2. [Remove Operation Panel](#)(Figures 702 thru 703).
3. Remove 7 screws.(Figure 704)
4. Unhinge electrical box. (Figure 705)
5. Using needle nose pliers or other suitable tool to squeeze standoffs (4 places, and pull back board from control box.
NOTE: It can be helpful to take a picture of the connections on the PCB before swapping over.
6. Swap terminals over from old board to new board and reinstall.

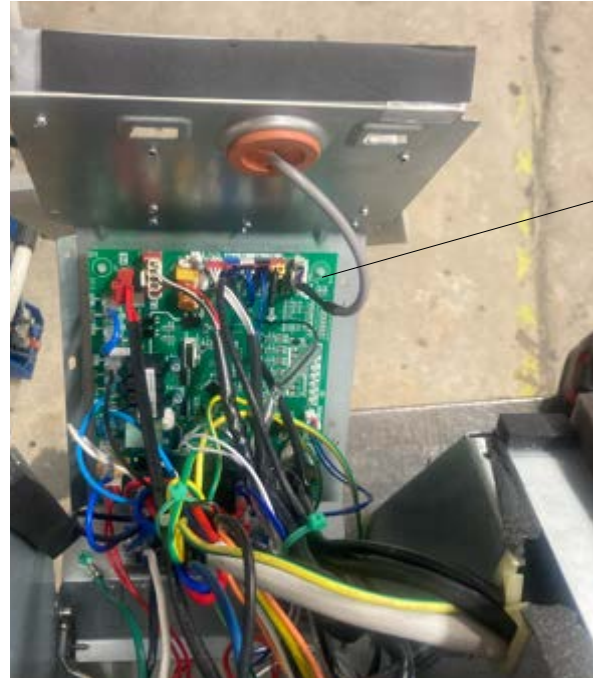

Standoff
(4 Places)

Figure 706 (Remove Main PCB (logic board))

UNIT DISASSEMBLY AND COMPONENT REPLACEMENT

Remove Power Cord

⚠ WARNING



ELECTRIC SHOCK HAZARD

Turn off electric power before service or installation. Extreme care must be used, if it becomes necessary to work on equipment with power applied.

Failure to do so could result in serious injury or death.

1. [Remove front panel](#) (Figure 701).
2. [Remove Operation Panel](#)(Figures 702 thru 703).
3. Remove 7 screws.(Figure 704)
4. Unhinge electrical box. (Figure 705)
5. Disconnect Wires From Main PCB(See Figure 707).
6. Remove Power cord access panel and replace power cord.

Disconnect Wires

Remove Power
Cord Access Panel

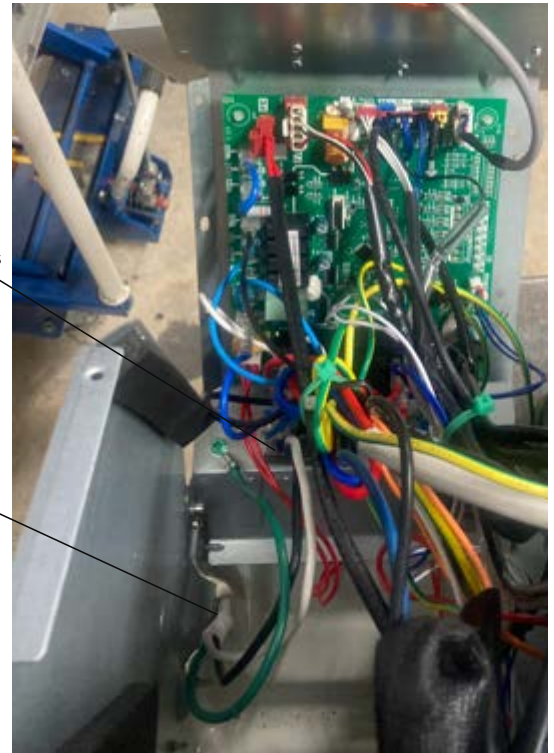

Figure 707 (Remove Power Cord)

UNIT DISASSEMBLY AND COMPONENT REPLACEMENT

Remove Blower Wheel Housing, Blower wheel, Motor and Electric Heater

⚠ WARNING



ELECTRIC SHOCK HAZARD

Turn off electric power before service or installation. Extreme care must be used, if it becomes necessary to work on equipment with power applied.

Failure to do so could result in serious injury or death.

1. [Remove front panel and chassis.](#) (Figure 701).
2. Remove Blower wheel screen, front grill bracket, rear grill bracket, right grill bracket, and left side panel. (See Figure 708 and 709)



Figure 708 (Remove Brackets)



Figure 709 (Brackets Removed)

UNIT DISASSEMBLY AND COMPONENT REPLACEMENT

Remove Blower Wheel Housing, Blower wheel, Motor and Electric Heater

3. Slide blower housing assembly out of unit
(See figure 710).



Figure 710 (Slide up Housing)

4. Replace Blower Wheel.

- a. Remove housing left side panel (See Figure 711).
- b. Loosen set screw (Do not remove!) with a 2.5 mm allen wrench (See figure 712).

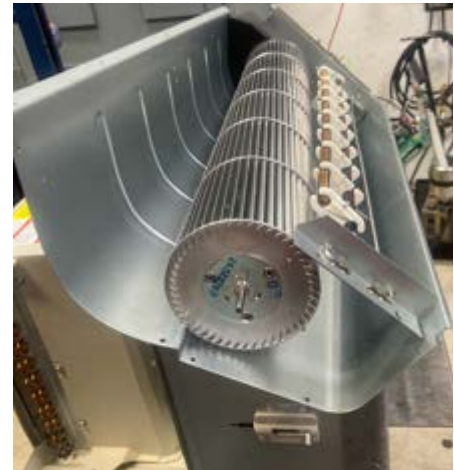

Figure 711 (Left Panel Removed)

5. Replace blower wheel motor.

- a. Loosen set screw (Do not remove!) with a 2.5 mm allen wrench (See figure 712).
- b. [Open Electrical control box \(See figure 704\)](#)
- c. Disconnect 2 plugs on main pcb.



Figure 712 (Loosen Set Screw)

UNIT DISASSEMBLY AND COMPONENT REPLACEMENT

Remove Blower Wheel Housing, Blower wheel, Motor and Electric Heater

- d. Remove fan mount bracket (3 screws) (See Figure 713)
- e. Remove motor.

Blower Wheel
Motor
Bracket

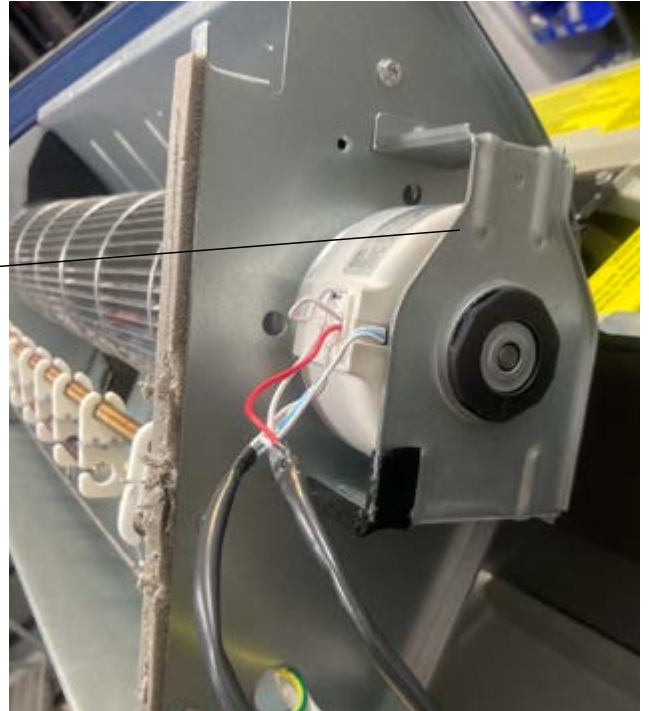

Figure 713(Motor Bracket)

6. Replace heater

- a. [Open Electrical control box.](#)
- b. Disconnect 2 terminals on Heater relays (See Figure 714).
- c. Remove 4 mounting screws (See figure 710).
- d. Remove Heater.

Heater
Wires

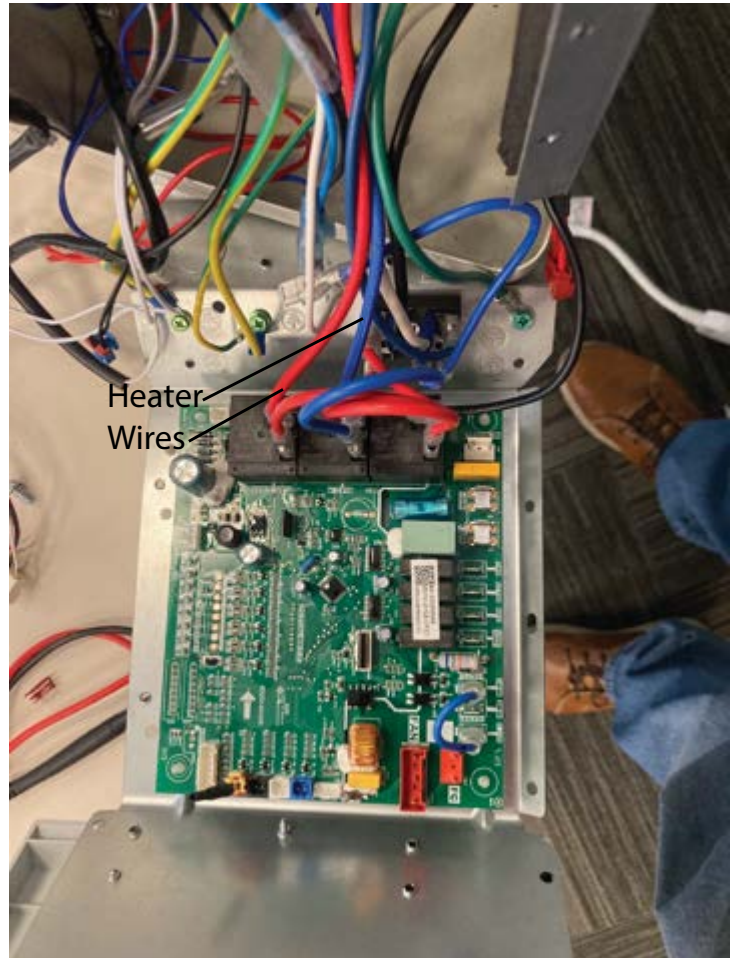



Figure 714 (Heater Wires)

UNIT DISASSEMBLY AND COMPONENT REPLACEMENT

Remove Outdoor Fan

⚠ WARNING	
	ELECTRIC SHOCK HAZARD
	Turn off electric power before service or installation. Extreme care must be used, if it becomes necessary to work on equipment with power applied.
	Failure to do so could result in serious injury or death.

1. [Remove front panel and chassis.](#) (Figure 701).
2. Remove 2 shroud supports
3. [Open Electrical control box \(See figure 704\).](#) Not required for Blade replacement)
4. Cut wire ties as required. Not required for Blade replacement)
5. Disconnect indoor blower terminals on main pcb. Not required for Blade replacement)
7. Disconnect Indoor blower capacitor connector. Not required for Blade replacement)

8. Remove outdoor fan shroud (9 screws)
9. Remove lower fan mount screws (2 ea).
10. Remove shroud from unit and replace blade and/ or motor as required.

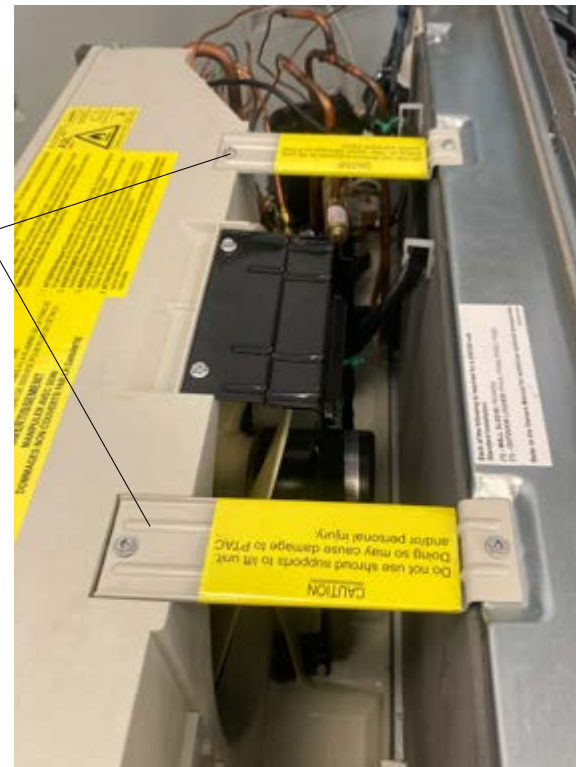

Figure 715 (Shroud Supports)



Figure 716 (Outdoor Fan Shroud)

R-32 SEALED SYSTEM REPAIR

General Information

WARNING: Electrical Shock Hazard

Disconnect all power to the unit before starting maintenance. All electrical connections and wiring **MUST** be installed by a qualified electrician and conform to all codes which have jurisdiction. Failure to do so can result in property damage, severe electrical shock or death.



WARNING: This Product uses R-454B Refrigerant

Do not use means to accelerate the defrosting process or to clean, other than those recommended by the manufacturer.

When not installed, the appliance shall be stored in a room without continuously operating ignition sources (for example: open flames, an operating gas appliance or an operating electric heater).

Do not pierce or burn.

Be aware that refrigerants may not contain an odor.



**Refrigerant
Safety Group
A2L**

WARNING: Refrigeration System under High pressure

Do not puncture, heat, expose to flame or incinerate. Only certified refrigeration technicians should service this equipment. R454B systems operate at higher pressures than R22 equipment. Appropriate safe service and handling practices must be used.

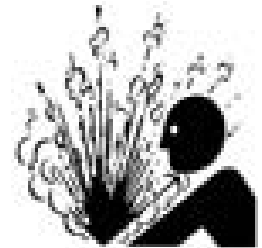

 **Warning:** Prior to beginning work on systems containing **FLAMMABLE REFRIGERANTS**, safety checks are necessary to ensure that the risk of ignition is minimized.

Work shall be undertaken under a controlled procedure so as to minimise the risk of a flammable gas or vapour being present while the work is being performed

General Work Area: All maintenance staff and others working in the installation area shall be instructed on the nature of work being carried out. Work in confined spaces as defined by the Occupational Safety And Health Administration shall be avoided.

Check for presence of refrigerant:

- The area shall be checked with an appropriate refrigerant detector prior to and during work, to ensure the technician is aware of potentially toxic or flammable atmospheres.
- Ensure that the leak detection equipment being used is suitable for use with all applicable refrigerants, i.e. non-sparking, adequately sealed or intrinsically safe.
- Under no circumstances shall potential sources of ignition be used in the searching for or detection of refrigerant leaks. A halide torch (or any other detector using a naked flame) shall not be used.
- The following leak detection methods are deemed acceptable for all refrigerant systems:
 1. Electronic leak detectors may be used to detect refrigerant leaks but, in the case of **FLAMMABLE REFRIGERANTS**, the sensitivity may not be adequate, or may need re-calibration. (Detection equipment shall be calibrated in a refrigerant-free area.) Ensure that the detector is not a potential source of ignition and is suitable for the refrigerant used. Leak detection equipment shall be set at a percentage of the LFL of the refrigerant and shall be calibrated to the refrigerant employed, and the appropriate percentage of gas (25 % maximum) is confirmed.
 2. Leak detection fluids are also suitable for use with most refrigerants but the use of detergents containing chlorine shall be avoided as the chlorine may react with the refrigerant and corrode the copper pipe-work.

NOTE: Examples of leak detection fluids are:

- Bubble Method

If a leak is suspected, all flame sources shall be removed/extinguished.

If a leakage of refrigerant is found which requires brazing, all of the refrigerant shall be recovered from the system, or isolated (by means of shut off valves) in a part of the system remote from the leak.

Presence of fire extinguisher: If any hot work is to be conducted on the refrigerating equipment or any associated parts, a class ABC Rated fire extinguishing equipment shall be available to hand. Have a class ABC Rated fire extinguisher adjacent to the charging area.

R-32 SEALED SYSTEM REPAIR

General Information

Warning:

No ignition sources: No person carrying out work in relation to a REFRIGERATING SYSTEM which involves exposing any pipe work shall use any sources of ignition in such a manner that it may lead to the risk of fire or explosion. All possible ignition sources, including cigarette smoking, should be kept sufficiently far away from the site of installation, repairing, removing and disposal, during which refrigerant can possibly be released to the surrounding space. Prior to work taking place, the area around the equipment is to be surveyed to make sure that there are no flammable hazards or ignition risks.

Ventilated Area: Ensure that the area is in the open or that it is adequately ventilated before accessing the refrigerant in the system or conducting any hot work. A degree of ventilation shall continue during the period that the work is carried out. The ventilation should safely disperse any released refrigerant and preferably expel it externally into the atmosphere.

During Repairs To Sealed Components: All power must be removed from the equipment being worked on prior to any removal of sealed covers, etc. If it is absolutely necessary to have an electrical supply to equipment during servicing, then a permanently operating form of leak detection shall be located at the most critical point to warn of a potentially hazardous situation.

Checks And Repairs To Electrical Devices:

- Repair and maintenance of electrical components shall include initial safety checks and component inspection procedures. If a fault exists that could compromise safety, then no electrical supply shall be connected to the circuit until it is satisfactorily dealt with. If the fault cannot be corrected immediately but it is necessary to continue operation, an adequate temporary solution shall be used. This shall be reported to the owner of the equipment so all parties are advised.
- Initial safety checks shall include:
 - That capacitors are discharged: this shall be done in a safe manner to avoid possibility of sparking;
 - That no live electrical components and wiring are exposed while charging, recovering or purging the system;
 - That there is continuity of earth bonding.
- Particular attention shall be paid to the following to ensure that by working on electrical components, the casing is not altered in such a way that the level of protection is affected. This shall include damage to cables, excessive number of connections, terminals not made to original specification, damage to seals, incorrect fitting of glands, etc.
- Ensure that the apparatus is mounted securely.
- Ensure that seals or sealing materials have not degraded to the point that they no longer serve the purpose of preventing the ingress of flammable atmospheres. Replacement parts shall be in accordance with the manufacturer's specifications.

The following is a list of important considerations when working with R-32 equipment:

- R-32 pressure is approximately 60% higher than R-22 pressure.
- R-32 cylinders must not be allowed to exceed 125 F, they may leak or rupture.
- R-32 must never be pressurized with a mixture of compressed air, it may become MORE flammable.
- Servicing equipment and components must be specifically designed for use with R-32 and dedicated to prevent contamination.
- Manifold sets must be equipped with gauges capable of reading 750 psig (high side) and 200 psig (low side), with a 500-psig low-side retard.
- Gauge hoses must have a minimum 750-psig service pressure rating.
- Recovery cylinders must have a minimum service pressure rating of 400 psig, (DOT 4BA400 and DOT BW400 approved cylinders).
- POE (Polyol-Ester) lubricants must be used with R-32 equipment.
- To prevent moisture absorption and lubricant contamination, do not leave the refrigeration system open to the atmosphere for extended periods of time.
- If the system is void of refrigerant, weigh-in the refrigerant charge into the high side of the system.
- If there is any amount of refrigerant in the system charge from the low side.
- For low side pressure charging of R-32, use a charging adaptor.

R-32 SEALED SYSTEM REPAIR

Required Equipment

- Multi-meter
- Ammeter
- R-32 E.P.A. Approved Refrigerant Recovery System
- Vacuum Pump rated for R-32 refrigerant (capable of 300 microns or less vacuum.)
- Oxy/ Acetylene torch or similar equipment utilized for brazing.
- Non-Sparking (Not Halide) Electronic Leak Detector rated for detecting R-32 refrigerant.
- Digital refrigerant scale
- High Pressure Gauge - (0 to 750 lbs.)
- Low Pressure Gauge - (-30 to 200 lbs.)
- Vacuum Gauge capable of 300 microns or less.
- Facilities for flowing nitrogen through refrigeration tubing during all brazing processes.

EQUIPMENT MUST BE CAPABLE OF:

- Recovering refrigerant to EPA required levels.
- Evacuation from both the high side and low side of the system simultaneously.
- Introducing refrigerant charge into high side of the system.
- Accurately weighing the refrigerant charge introduced into the system.

R-32 SEALED SYSTEM REPAIR

Refrigerant Removal, Recovery, and Evacuation

NOTE: When accessing the refrigerant in the system to make repairs or for any other purpose, conventional procedures shall be used. However, for FLAMMABLE REFRIGERANTS (R-32 is classified in the A2L group for mildly flammable refrigerants) it is important that best practice is followed since flammability is a consideration.

 **Warning:** Ensure sufficient ventilation at the repair place.

 **Warning:** Ensure there are no open flame sources or hot surfaces that exceed 1200°F in the work area.

 **Warning:** Discharge capacitors in a way that won't cause any spark. The standard procedure to short circuit the capacitor terminals usually creates sparks.

1. Install a piercing valve to remove refrigerant from the sealed system. (Piercing valve must be removed from the system before recharging.)
2. Safely remove refrigerant following local and national regulations. (Refer to local governing bodies for refrigerant handling.)

Recovery

- a. When transferring refrigerant into cylinders, ensure that only appropriate refrigerant recovery cylinders are employed. Ensure that the correct number of cylinders for holding the total system charge is available. All cylinders to be used are designated for the recovered refrigerant and labelled for that refrigerant (i.e. special cylinders for the recovery of refrigerant). Cylinders shall be complete with pressure-relief valve and associated shut-off valves in good working order. Empty recovery cylinders are evacuated and, if possible, cooled before recovery occurs.
- b. Make sure that cylinder is situated on the scales before recovery takes place. The recovery equipment shall be in good working order with a set of instructions concerning the equipment that is at hand and shall be suitable for the recovery of the flammable refrigerant. In addition, a set of calibrated weighing scales shall be available and in good working order. Hoses shall be complete with leak-free disconnect couplings and in good condition.
- c. Do not mix refrigerants in recovery units and especially not in cylinders.
- d. If compressors or compressor oils are to be removed, ensure that they have been evacuated to an acceptable level to make certain that FLAMMABLE REFRIGERANT does not remain within the lubricant. The evacuation process shall be carried out prior to returning the compressor for inspection. Only electric-type heating to the compressor body shall be employed to accelerate this process. When oil is drained from a system, it shall be carried out safely.
- e. Start the recovery machine and operate in accordance with instructions.
- f. Do not overfill cylinders (no more than 80 % volume liquid charge).
- g. Do not exceed the maximum working pressure of the cylinder, even temporarily.
- h. When the cylinders have been filled correctly and the process completed, make sure that the cylinders and the equipment are removed from site promptly and all isolation valves on the equipment are closed off.

3. Open the circuit by cutting with a refrigeration tubing cutter. Always open the low side first.

The refrigerant charge shall be recovered into the correct recovery cylinders.

Transportation

Be aware that local, state, and national codes exist that regulate the transportation of flammable gases. Be sure to become informed of the regulations and always stay compliant.

R-32 SEALED SYSTEM REPAIR

Component Replacement/Brazing

 **Warning:** Ensure sufficient ventilation at the repair place.

 **Warning: Presence of fire extinguisher.** If any hot work is to be conducted on the refrigerating equipment or any associated parts, have a ABC class fire extinguisher available to hand.

 **Warning:** No person carrying out work in relation to a REFRIGERATING SYSTEM which involves exposing any pipe work shall use any sources of ignition in such a manner that it may lead to the risk of fire or explosion. All possible ignition sources, including cigarette smoking, should be kept sufficiently far away from the site of installation, repairing, removing and disposal, during which refrigerant can possibly be released to the surrounding space. Prior to work taking place, the area around the equipment is to be surveyed to make sure that there are no flammable hazards or ignition risks.

 **Warning:** Ensure there are no open flame sources or hot surfaces that exceed 1200°F in the work area.

NOTE: When brazing is required, the following procedures shall be carried out in the right order:

1. Install a piercing valve to remove refrigerant from the sealed system. (Piercing valve must be removed from the system before recharging.)
2. Remove and recover refrigerant, and evacuate the system. Refer to the [refrigerant removal, recovery, and evacuation section](#) of this manual.
3. Remove parts to be replaced by cutting, not by flame.
4. Perform a check of the work area for the presence of flammable refrigerant prior to brazing or performing any hot work. Use a non-Sparking (Not Halide) Electronic Leak Detector rated for detecting R-32 refrigerant.

 **Warning:** Under no circumstances shall potential sources of ignition be used in the searching for or detection of refrigerant leaks. A halide torch (or any other detector using a naked flame) shall not be used.

Ensure that the detector is not a potential source of ignition and is A2L certified leak detector.

5. Purge the braze point with nitrogen during the brazing procedure.
6. Pressurize nitrogen to 550 psi and leak test all connections with a leak detection fluid. Repair any leaks found.
7. Reassemble sealed enclosures accurately. If seals are worn, replace them.
8. Install a process tube to sealed system.
9. Charge the system with the amount of refrigerant specified on the model nameplate. Refer to the [refrigerant charging section](#) of this manual for charging procedures.
10. Check safety equipment before putting into service.

R-32 SEALED SYSTEM REPAIRS

Refrigerant Charging

WARNING: Electrical Shock Hazard

Disconnect all power to the unit before starting maintenance. All electrical connections and wiring **MUST** be installed by a qualified electrician and conform to all codes which have jurisdiction. Failure to do so can result in property damage, severe electrical shock or death.



WARNING: This Product uses R-32 Refrigerant

Do not use means to accelerate the defrosting process or to clean, other than those recommended by the manufacturer.

When not installed, the appliance shall be stored in a room without continuously operating ignition sources (for example: open flames, an operating gas appliance or an operating electric heater).

Do not pierce or burn.

Be aware that refrigerants may not contain an odor.



WARNING: Refrigeration System under High pressure

Do not puncture, heat, expose to flame or incinerate. Only certified refrigeration technicians should service this equipment. R32 systems operate at higher pressures than R22 equipment. Appropriate safe service and handling practices must be used.

WARNING: Freeze Hazard

Proper safety procedures must be followed, and all PPE must be utilized when working with liquid refrigerant. Failure to comply could result in minor to moderate injury.

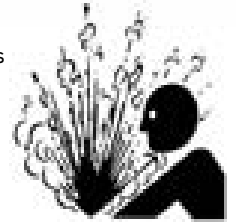

NOTE: Always weigh in refrigerant based on the model nameplate.

Warning:

- Ensure that contamination of different refrigerants does not occur when using charging equipment.
- Hoses or lines shall be as short as possible to minimise the amount of refrigerant contained in them.
- Cylinders shall be kept in an appropriate position according to the instructions.
- Ensure that the REFRIGERATING SYSTEM is grounded prior to charging the system with refrigerant.
- Label the system when charging is complete (if not already).
- Extreme care shall be taken not to overfill the REFRIGERATING SYSTEM.
- Prior to recharging a system, it shall be pressure-tested with the appropriate purging gas. The system shall be leak-tested on completion of charging but prior to commissioning. A follow up leak test shall be carried out prior to leaving the site.
-

NOTE: Because the refrigerant system is a sealed system, service process tubes will have to be installed. First install a line tap and remove refrigerant from system. Refer to the Refrigerant removal section of this manual for procedures. Make necessary sealed system repairs and vacuum system.

The acceptable method for charging the sealed system is the Weighed in Charge Method. The weighed in charge method is applicable to all units. It is the preferred method to use, as it is the most accurate.

The weighed in method should always be used whenever a charge is removed from a unit such as for a leak repair, compressor replacement, or when there is no refrigerant charge left in the unit. To charge by this method, requires the following steps:

R-32 SEALED SYSTEM REPAIRS

Refrigerant Charging

⚠ WARNING	
	BURN HAZARD Proper safety procedures must be followed, and proper protective clothing must be worn when working with a torch. Failure to follow these procedures could result in moderate or serious injury.

⚠ CAUTION	
	FREEZE HAZARD Proper safety procedures must be followed, and proper protective clothing must be worn when working with liquid refrigerant. Failure to follow these procedures could result in minor to moderate injury.

⚠ Warning: Ensure sufficient ventilation at the repair place.

⚠ Warning: Ensure there are no open flame sources or hot surfaces that exceed 1200°F in the work area.

1. Install a piercing valve to remove refrigerant from the sealed system. (Piercing valve must be removed from the system before recharging.)
2. Recover Refrigerant in accordance with EPA regulations. (Refer to [Refrigerant Removal, Recovery, and Evacuation Section](#).)
3. Install a process tube to sealed system.

NOTE: Access valves must be removed after charging is complete to return this unit to a sealed system.

4. Evacuate the system to 1500 microns.
5. Repressurize to 50 PSI with nitrogen.
6. Evacuate the system to 1000 microns.
7. Repressurize to 50 PSI with nitrogen.
8. Evacuate the system to below 500 microns.
9. Turn off vacuum pump and confirm microns do not rise above 1000.
10. Weigh in the refrigerant charge with the property quantity of R-32 refrigerant per model nameplate.
11. Start unit, and verify performance.
12. Crimp the process tube and solder the end shut.

NOTE: EPA Section 608 regulations require that if a system is charged with flammable refrigerant it must have red markings on the access ports.

R-32 SEALED SYSTEM REPAIRS

Compressor Replacement

⚠ WARNING	
	<p>ELECTRIC SHOCK HAZARD Turn off electric power before service or installation. Extreme care must be used, if it becomes necessary to work on equipment with power applied.</p> <p>Failure to do so could result in serious injury or death.</p>

⚠ WARNING	
	<p>HIGH PRESSURE HAZARD Sealed Refrigeration System contains refrigerant and oil under high pressure.</p> <p>Proper safety procedures must be followed, and proper protective clothing must be worn when working with refrigerants.</p> <p>Failure to follow these procedures could result in serious injury or death.</p>

⚠ WARNING	
	<p>EXPLOSION HAZARD The use of nitrogen requires a pressure regulator. Follow all safety procedures and wear protective safety clothing etc.</p> <p>Failure to follow proper safety procedures could result in serious injury or death.</p>

⚠ CAUTION	
	<p>FREEZE HAZARD Proper safety procedures must be followed, and proper protective clothing must be worn when working with liquid refrigerant.</p> <p>Failure to follow these procedures could result in minor to moderate injury.</p>

⚠ WARNING	
	<p>NEVER, under any circumstances, liquid charge a rotary-compressor through the LOW side. Doing so would cause permanent damage to the new compressor. Use a charging adapter.</p>

1. Be certain to perform all necessary electrical and refrigeration tests to be sure the compressor is actually defective before replacing.

2. Recover all refrigerant from the system through the process tubes. Refer to [Refrigerant Removal, Recovery, and Evacuation Section](#) of this manual).

PROPER HANDLING OF RECOVERED REFRIGERANT ACCORDING TO EPA REGULATIONS IS REQUIRED.

3. After all refrigerant has been recovered, disconnect suction and discharge lines from the compressor and remove compressor. Be certain to have both suction and discharge process tubes open to atmosphere.

4. Carefully pour a small amount of oil from the suction stub of the defective compressor into a clean container.

5. Using an acid test kit (one shot or conventional kit), test the oil for acid content according to the instructions with the kit.

6. If any evidence of a burnout is found, no matter how slight, refer to Compressor Replacement -Special Procedure in Case of Compressor Burnout.

7. Install the replacement compressor.

CAUTION: Seal all openings on the defective compressor immediately. Compressor manufacturers will void warranties on units received not properly sealed. Do not distort the manufacturers tube connections.

8. Braze all connections. Refer to the [Brazing section](#) of this manual.

9. Pressurize with nitrogen to 550 psi and leak test all connections with a leak detection fluid. Repair any leaks found.

10. Charge system with proper amount of refrigerant per the model nameplate. Refer to the [refrigerant charging section](#) of this manual.

R-32 SEALED SYSTEM REPAIRS

Compressor Replacement -Special Procedure in Case of Compressor Burnout

⚠ WARNING	
	<p>HIGH PRESSURE HAZARD Sealed Refrigeration System contains refrigerant and oil under high pressure.</p> <p>Proper safety procedures must be followed, and proper protective clothing must be worn when working with refrigerants.</p> <p>Failure to follow these procedures could result in serious injury or death.</p>

⚠ WARNING	
	<p>ELECTRIC SHOCK HAZARD Turn off electric power before service or installation. Extreme care must be used, if it becomes necessary to work on equipment with power applied.</p> <p>Failure to do so could result in serious injury or death.</p>

⚠ WARNING	
	<p>EXPLOSION HAZARD The use of nitrogen requires a pressure regulator. Follow all safety procedures and wear protective safety clothing etc.</p> <p>Failure to follow proper safety procedures could result in serious injury or death.</p>

⚠ WARNING	
	<p>NEVER, under any circumstances, liquid charge a rotary-compressor through the LOW side. Doing so would cause permanent damage to the new compressor. Use a charging adapter.</p>

1. Recover all refrigerant and oil from the system. Refer to [Refrigerant Removal, Recovery, and Evacuation](#) Section of this manual.

2. Remove compressor, capillary tube and filter drier from the system.

CAUTION: Seal all openings on the defective compressor immediately. Compressor manufacturers will void warranties on units received not properly sealed. Do not distort the manufacturers tube connections.

3. Flush evaporator condenser and all connecting tubing with dry nitrogen or equivalent. Use approved flushing agent to remove all contamination from system. Inspect suction and discharge line for carbon deposits. Remove and clean if necessary. Ensure all acid is neutralized.

4. Reassemble the system, including new drier strainer and capillary tube.

5. Braze all connections. Refer to the [Brazing section](#) of this manual.

6. Pressurize with nitrogen to 550 psi and leak test all connections with a leak detection fluid. Repair any leaks found.

Repeat Step 6 to insure no more leaks are present.

7. Charge system with proper amount of refrigerant per the model nameplate. Refer to the [refrigerant charging section](#) of this manual.

WIRING DIAGRAMS

PZE

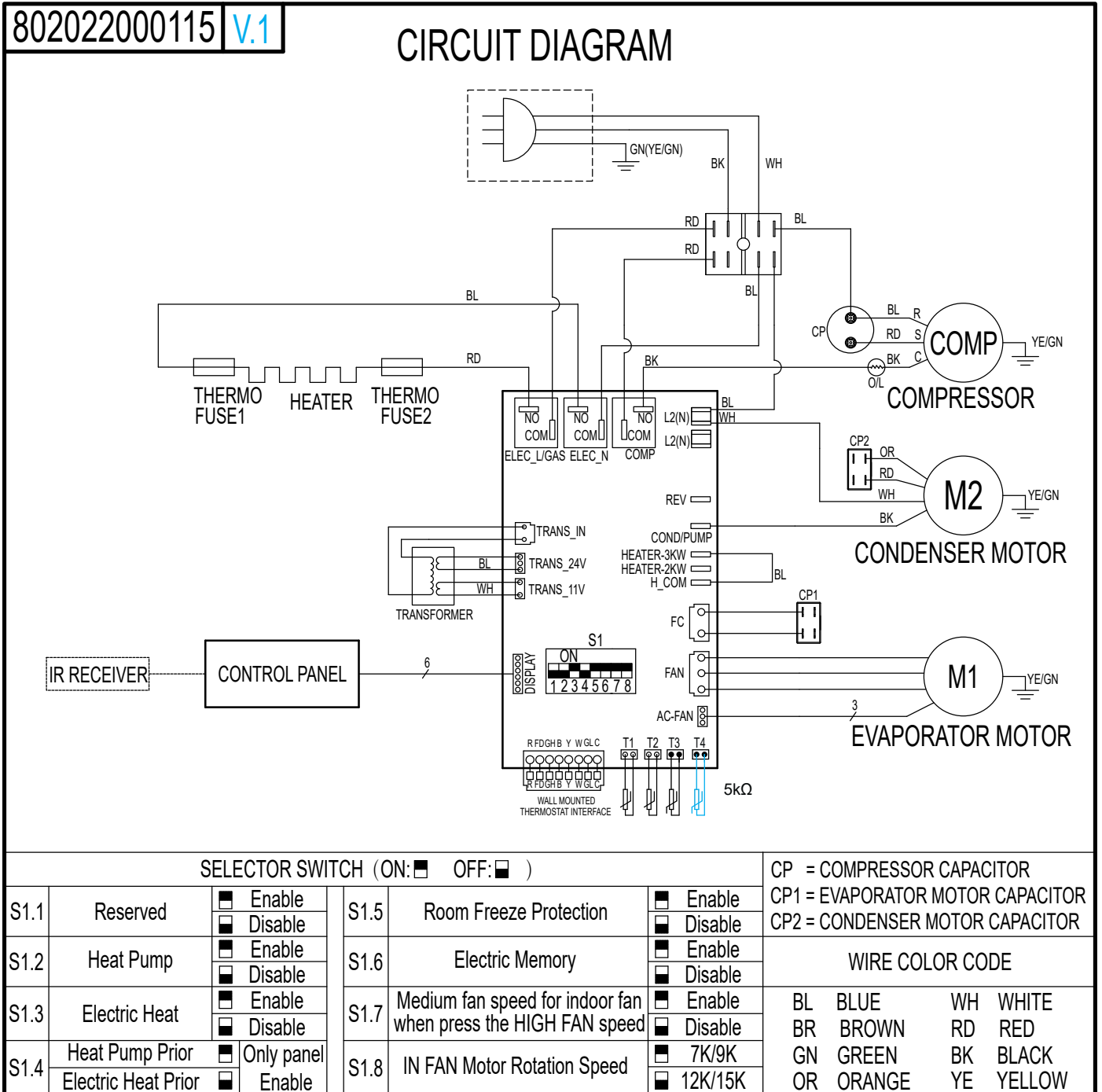

Figure 801

WIRING DIAGRAMS

PZH

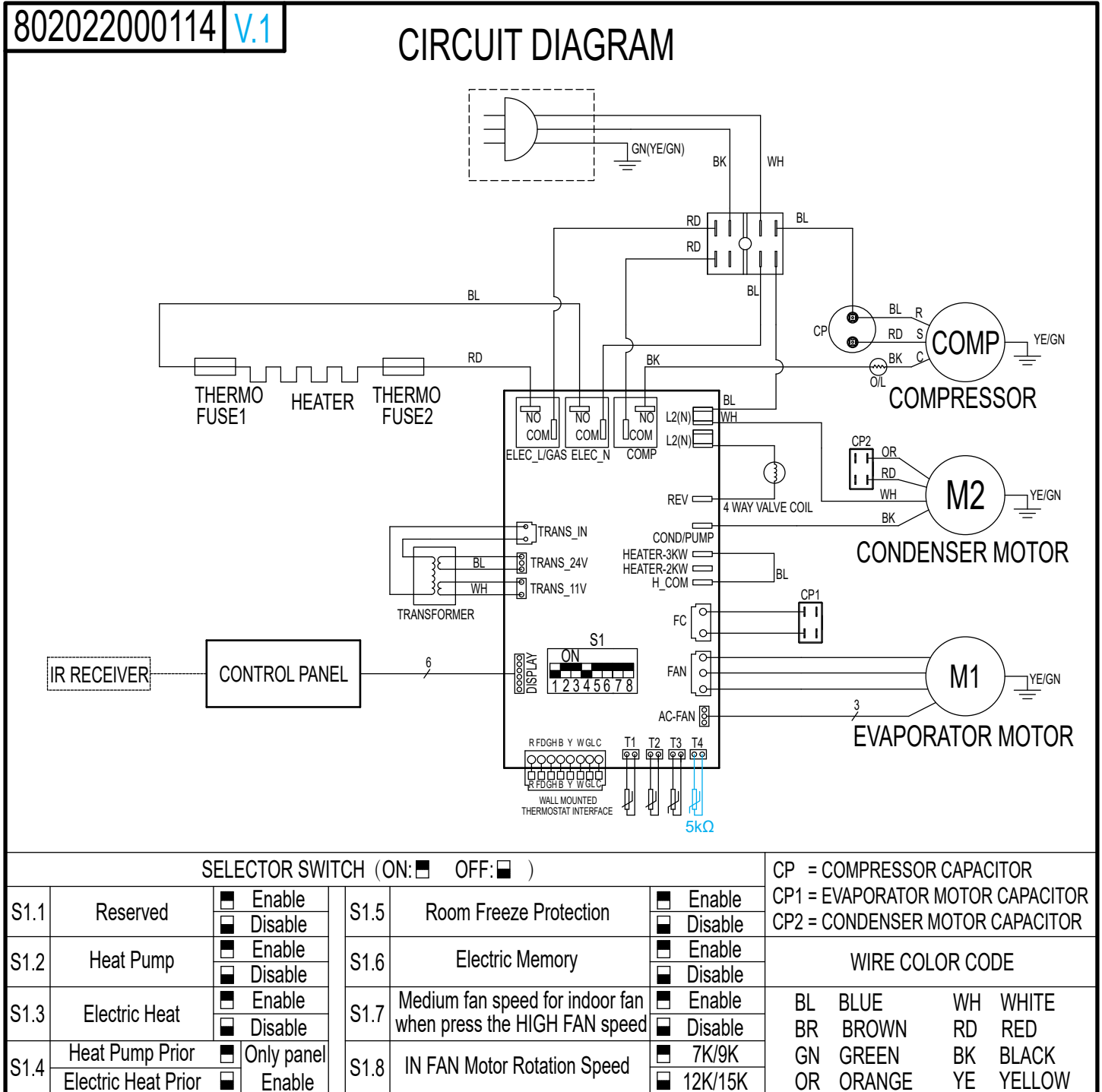

Figure 802

APPENDIX

Interactive Parts Viewer

All Friedrich Service Parts can be found on our online interactive parts viewer.

Please click on the link below:

[Interactive Parts Viewer](#)

For Further Assistance contact Friedrich customer service at **(1-800-541-6645)**.

Limited Warranty

Current warranty information can be obtained by referring to <https://www.friedrich.com/professional/support/product-resources>

APPENDIX

Reference Sheet of Celsius and Fahrenheit

Conversion formula for Fahrenheit degree and Celsius degree: $T_f = T_c \times 1.8 + 32$

Set temperature

Fahrenheit display temperature (°F)	Fahrenheit (°F)	Celsius(°C)	Fahrenheit display temperature (°F)	Fahrenheit (°F)	Celsius (°C)	Fahrenheit display temperature (°F)	Fahrenheit (°F)	Celsius (°C)
61	60.8	16	69/70	69.8	21	78/79	78.8	26
62/63	62.6	17	71/72	71.6	22	80/81	80.6	27
64/65	64.4	18	73/74	73.4	23	82/83	82.4	28
66/67	66.2	19	75/76	75.2	24	84/85	84.2	29
68	68	20	77	77	25	86	86	30

Ambient temperature

Fahrenheit display temperature (°F)	Fahrenheit (°F)	Celsius(°C)	Fahrenheit display temperature (°F)	Fahrenheit (°F)	Celsius(°C)	Fahrenheit display temperature (°F)	Fahrenheit (°F)	Celsius(°C)
32/33	32	0	55/56	55.4	13	79/80	78.8	26
34/35	33.8	1	57/58	57.2	14	81	80.6	27
36	35.6	2	59/60	59	15	82/83	82.4	28
37/38	37.4	3	61/62	60.8	16	84/85	84.2	29
39/40	39.2	4	63	62.6	17	86/87	86	30
41/42	41	5	64/65	64.4	18	88/89	87.8	31
43/44	42.8	6	66/67	66.2	19	90	89.6	32
45	44.6	7	68/69	68	20	91/92	91.4	33
46/47	46.4	8	70/71	69.8	21	93/94	93.2	34
48/49	48.2	9	72	71.6	22	95/96	95	35
50/51	50	10	73/74	73.4	23	97/98	96.8	36
52/53	51.8	11	75/76	75.2	24	99	98.6	37
54	53.6	12	77/78	77	25			

APPENDIX

Resistance Table of Thermistors (5K)

Temp	Resis	Temp	Resis	Temp	Resis	Temp	Resis	Temp	Resis
-33	130100	7	34252	47	10785	57	8275	97	3119
-32	125518	8	33209	48	10499	58	8063	98	3048
-31	121114	9	32202	49	10221	59	7857	99	2980
-30	116881	10	31228	50	9952	60	7657	100	2913
-29	112811	11	30288	51	9690	61	7462	101	2848
-28	108898	12	29378	52	9437	62	7273	102	2785
-27	105131	13	28499	53	9190	63	7090	103	2723
-26	101511	14	27650	54	8952	64	6911	104	2662
-25	98029	15	26828	55	8720	65	6738	105	2604
-24	94676	16	26034	56	8494	66	6569	106	2546
-23	91453	17	25266	57	8275	67	6406	107	2491
-22	88349	18	24523	58	8063	68	6247	108	2436
-21	85362	19	23805	59	7857	69	6092	109	2383
-20	82486	20	23110	60	7657	70	5942	110	2331
-19	79719	21	22437	61	7462	71	5796	111	2281
-18	77052	22	21787	62	7273	72	5654	112	2231
-17	74486	23	21158	63	7090	73	5515	113	2183
-16	72014	24	20548	64	6911	74	5381	114	2137
-15	69633	25	19959	65	6738	75	5251	115	2091
-14	67338	26	19388	66	6569	76	5124	116	2046
-13	65127	27	18836	67	6406	77	5000	117	2003
-12	62996	28	18301	68	6247	78	4880	118	1960
-11	60943	29	17783	69	6092	79	4763	119	1919
-10	58965	30	17282	70	5942	80	4649	120	1878
-9	57055	31	16796	71	5796	81	4538	121	1839
-8	55216	32	16325	72	5654	82	4431	122	1800
-7	53442	33	15870	73	5515	83	4326	123	1763
-6	51732	34	15428	74	5381	84	4224	124	1726
-5	50082	35	15001	75	5251	85	4125	125	1690
-4	48490	36	14586	76	5124	86	4028	126	1655
-3	46955	37	14184	77	5000	87	3934	127	1621
-2	45473	38	13795	78	4880	88	3842	128	1588
-1	44044	39	13418	79	4763	89	3753	129	1555
0	42664	40	13052	80	4649	90	3666	130	1524
1	41332	41	12698	81	4538	91	3582	131	1493
2	40047	42	12354	82	4431	92	3499	132	1462
3	38805	43	12021	83	4326	93	3419	133	1433
4	37607	44	11698	84	4224	94	3341	134	1404
5	36450	45	11384	85	4125	95	3265	135	1375
6	35332	46	11080	86	4028	96	3191	136	1348

APPENDIX

Resistance Table of Thermistors (5K)

Temp	Resis	Temp	Resis	Temp	Resis	Temp	Resis	Temp	Resis
137	1321	162	812	187	517	212	339	237	229
138	1294	163	797	188	508	213	334	238	226
139	1269	164	782	189	499	214	329	239	222
140	1244	165	768	190	491	215	323	240	219
141	1219	166	754	191	482	216	318	241	216
142	1195	167	740	192	474	217	313	242	212
143	1171	168	727	193	466	218	308	243	209
144	1148	169	713	194	458	219	303	244	206
145	1126	170	700	195	450	220	298	245	203
146	1104	171	688	196	443	221	294	246	200
147	1083	172	675	197	435	222	289	247	197
148	1062	173	663	198	428	223	285	248	194
149	1041	174	651	199	421	224	280	249	191
150	1021	175	640	200	414	225	276	250	189
151	1001	176	628	201	407	226	271		
152	982	177	617	202	400	227	267		
153	964	178	606	203	394	228	263		
154	945	179	595	204	387	229	259		
155	927	180	585	205	381	230	255		
156	910	181	574	206	374	231	251		
157	893	182	564	207	368	232	247		
158	876	183	554	208	362	233	244		
159	859	184	545	209	356	234	240		
160	843	185	535	210	351	235	236		
161	828	186	526	211	345	236	233		

APPENDIX

Resistance Table of Thermistors (50K)(Compressor Discharge Sensor

Temp	Resis	Temp	Resis	Temp	Resis	Temp	Resis	Temp	Resis
-40	167862	0	42664	40	13052	80	4649	120	1878
-39	161791	1	41332	41	12698	81	4538	121	1839
-38	155965	2	40047	42	12354	82	4431	122	1800
-37	150368	3	38805	43	12021	83	4326	123	1763
-36	144994	4	37607	44	11698	84	4224	124	1726
-35	139828	5	36450	45	11384	85	4125	125	1690
-34	134866	6	35332	46	11080	86	4028	126	1655
-33	130100	7	34252	47	10785	87	3934	127	1621
-32	125518	8	33209	48	10499	88	3842	128	1588
-31	121114	9	32202	49	10221	89	3753	129	1555
-30	116881	10	31228	50	9952	90	3666	130	1524
-29	112811	11	30288	51	9690	91	3582	131	1493
-28	108898	12	29378	52	9437	92	3499	132	1462
-27	105131	13	28499	53	9190	93	3419	133	1433
-26	101511	14	27650	54	8952	94	3341	134	1404
-25	98029	15	26828	55	8720	95	3265	135	1375
-24	94676	16	26034	56	8494	96	3191	136	1348
-23	91453	17	25266	57	8275	97	3119	137	1321
-22	88349	18	24523	58	8063	98	3048	138	1294
-21	85362	19	23805	59	7857	99	2980	139	1269
-20	82486	20	23110	60	7657	100	2913	140	1244
-19	79719	21	22437	61	7462	101	2848	141	1219
-18	77052	22	21787	62	7273	102	2785	142	1195
-17	74486	23	21158	63	7090	103	2723	143	1171
-16	72014	24	20548	64	6911	104	2662	144	1148
-15	69633	25	19959	65	6738	105	2604	145	1126
-14	67338	26	19388	66	6569	106	2546	146	1104
-13	65127	27	18836	67	6406	107	2491	147	1083
-12	62996	28	18301	68	6247	108	2436	148	1062
-11	60943	29	17783	69	6092	109	2383	149	1041
-10	58965	30	17282	70	5942	110	2331	150	1021
-9	57055	31	16796	71	5796	111	2281	151	1001
-8	55216	32	16325	72	5654	112	2231	152	982
-7	53442	33	15870	73	5515	113	2183	153	964
-6	51732	34	15428	74	5381	114	2137	154	945
-5	50082	35	15001	75	5251	115	2091	155	927
-4	48490	36	14586	76	5124	116	2046	156	910
-3	46955	37	14184	77	5000	117	2003	157	893
-2	45473	38	13795	78	4880	118	1960	158	876
-1	44044	39	13418	79	4763	119	1919	159	859

APPENDIX

Resistance Table of Thermistors (50K) (Compressor Discharge Sensor)

Temp	Resis	Temp	Resis	Temp	Resis	Temp	Resis	Temp	Resis
160	843	178	606	196	443	214	329	232	247
161	828	179	595	197	435	215	323	233	244
162	812	180	585	198	428	216	318	234	240
163	797	181	574	199	421	217	313	235	236
164	782	182	564	200	414	218	308	236	233
165	768	183	554	201	407	219	303	237	229
166	754	184	545	202	400	220	298	238	226
167	740	185	535	203	394	221	294	239	222
168	727	186	526	204	387	222	289	240	219
169	713	187	517	205	381	223	285	241	216
170	700	188	508	206	374	224	280	242	212
171	688	189	499	207	368	225	276	243	209
172	675	190	491	208	362	226	271	244	206
173	663	191	482	209	356	227	267	245	203
174	651	192	474	210	351	228	263	246	200
175	640	193	466	211	345	229	259	247	197
176	628	194	458	212	339	230	255	248	194
177	617	195	450	213	334	231	251	249	191
								250	189

APPENDIX

Friedrich Authorized Parts Depots

United Products Distributors Inc.

4030A Benson Ave
Halethorpe, MD 21227
888-907-9675
c.businsky@updinc.com

Shivani Refrigeration & Air Conditioning Inc.

2259 Westchester Ave.
Bronx, NY 10462
sales@shivanionline.com

NEUCO Inc.

515 W Crossroads Parkway
Bolingbrook, IL 60440
312.809.1418
borr@neuco.com

The Gabbert Company

6868 Ardmore
Houston, Texas 77054

713-747-4110
800-458-4110

Johnstone Supply of Woodside

27-01 Brooklyn Queens Expway Woodside,
New York 11377

718-545-5464
800-431-1143

Reeve Air Conditioning, Inc.

2501 South Park Road
Hallandale, Florida 33009

954-962-0252
800-962-3383

Total Home Supply

26 Chapin Rd Ste 1109
Pine Brook, NJ 07058
877-847-0050

support@totalhomesupply.com
<https://www.totalhomesupply.com/brands/Friedrich.html>



FRIEDRICH

TECHNICAL SUPPORT CONTACT INFORMATION

Friedrich Air Conditioning Co.
10001 Reunion Place, Suite 500 • San Antonio, Texas 78216
1-800-541-6645
www.friedrich.com