



Ford/Lincoln/Mercury 2004-up

KIT FEATURES

95-5812: MetraOnline.com/part/95-5812

- ISO DDIN radio provision

99-5812: MetraOnline.com/part/99-5812

- DIN radio provision with pocket
- ISO DIN radio provision with pocket

KIT COMPONENTS

95-5812: • A1) Radio housing A • B1) ISO DDIN brackets • C1) Spacers • D1) (4) Screws

99-5812: • A2) Radio housing B • B2) ISO brackets • C2) Trim plate • D2) Side brackets • E2) Spacers • F2) (4) Screws

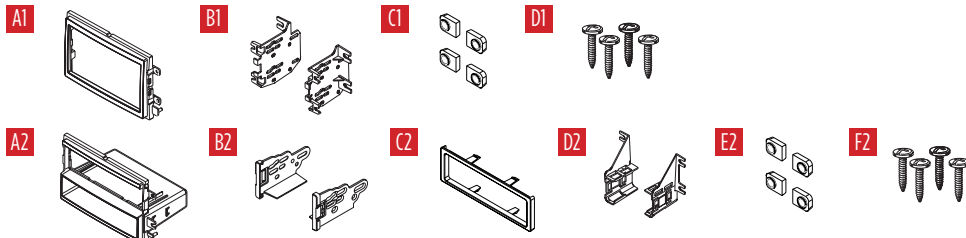

APPLICATIONS

See application list inside cover

TABLE OF CONTENTS

Please see inside front cover

WIRING & ANTENNA CONNECTIONS (sold separately)

Wiring Harness: Please visit metraonline.com for wiring harness options

Antenna Adapter: 40-CR10

TOOLS REQUIRED

- Cutting tool • Panel removal tool
- Phillips screwdriver • Socket set

Attention! Let the vehicle sit with the key out of the ignition for a few minutes before removing the factory radio. When testing the aftermarket equipment, ensure that all factory equipment is connected before cycling the key to ignition.

APPLICATIONS

Ford

Econoline (E-Series).....	2009-up
Edge.....	2007-2010
Expedition	2007-2014
Expedition (fleet).....	2015
Explorer	2006-2010
Explorer Sport Trac	2006-2010
F-150.....	2004-2008
F-250/350/450/550	2005-2012
F-250/350/450/550 (without 8" screen).....	2013-2016
F-650/750.....	2011-up
Five Hundred	2005-2007
Focus	2005-2007
Freestar	2004-2007
Freestyle	2005-2007
Fusion	2006-2009
Mustang	2005-2009
Taurus	2008-2009
Taurus X	2008-2009
Transit Connect (late generation).....	2012
Transit Connect.....	2013

Lincoln

Mark LT	2006-2008
MKX (with NAV).....	2007-2010
Navigator (with NAV)	2007-2014

Mercury

Milan	2006-2009
Mountaineer	2006-2010
Monterey	2004-2007
Montego	2005-2007
Sable	2008-2009

TABLE OF CONTENTS

Dash Disassembly

Ford

- Econoline (E-Series) 2009-up	7
- Edge 2007-2010	3
- Expedition 2007-2014	3
- Expedition (fleet) 2015	3
- Explorer 2006-2010.....	6
- Explorer Sport Trac 2006-2010	6
- F-150 2004-2008.....	3
- F-250/350/450/550 2005-2012	7
- F-250/350/450/550 (without 8" screen) 2013-2016.....	7
- F-650/750 2011-up.....	7
- Five Hundred 2005-2007	4
- Focus 2005-2007	6
- Freestar 2004-2007.....	5
- Freestyle 2005-2007	5
- Fusion 2006-2009	4
- Mustang 2005-2009.....	3
- Taurus 2008-2009	4
- Taurus X 2008-2009	5
- Transit Connect (late generation) 2012.....	7
- Transit Connect 2013.....	7

Lincoln

- Mark LT 2006-2008.....	3
- MKX (with NAV) 2007-2010.....	8

Mercury

- Navigator (with NAV) 2007-2014	8
- Milan 2006-2009.....	4
- Mountaineer 2006-2010	6
- Monterey 2004-2007.....	5
- Montego 2005-2007.....	4
- Sable 2008-2009.....	4

Kit Assembly

- DIN radio provision with pocket	9
- ISO DIN radio provision with pocket.....	10
- ISO DDIN radio provision.....	11

DASH DISASSEMBLY

Ford F-150 2004-2008

Ford Edge 2007-2010

Ford Expedition 2007-2014

Ford Expedition (fleet) 2015

Lincoln Mark LT 2006-2008

1. Unsnap and remove entire panel surrounding the radio and climate controls. (Figure A)
2. Remove (4) 9/32" screws to remove the factory radio. (Figure B)

Continue to Kit Assembly

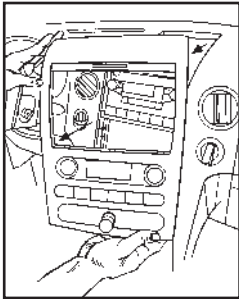

(Figure A)

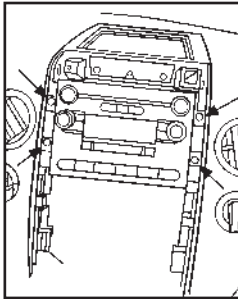

(Figure B)

Ford Mustang 2005-2009

1. Remove the small rectangular shifter lever trim panel if equipped. (Figure A)
2. Remove (2) Phillips screws from under the center armrest at the back of the shifter trim panel (including cup holders). (Figure B)
3. Unclip and remove panel. (Figure B)
4. Unclip and remove the (2) center stack trim panels from the left and right side of the radio and climate controls. (Figure C)
5. Remove (6) 9/32" screws from center trim panel surrounding the radio and climate controls then unclip and remove panel. (Figure D)
6. Remove (4) 9/32" screws from the radio to remove. (Figure E)

Continue to Kit Assembly

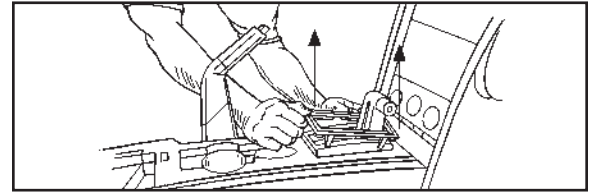

(Figure A)

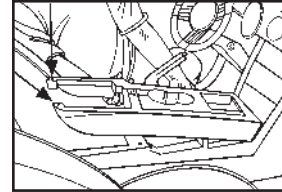

(Figure B)

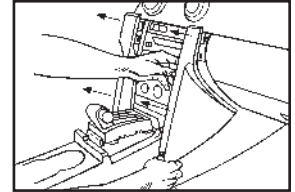

(Figure C)

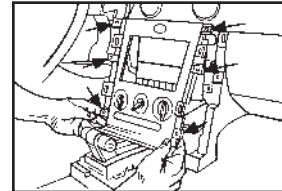

(Figure D)

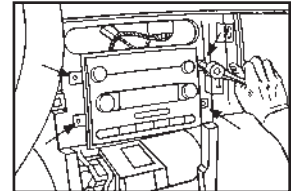

(Figure E)

DASH DISASSEMBLY

Ford Five Hundred 2005-2007

Ford Taurus 2008-2009

Mercury Montego 2005-2007

Mercury Sable 2008-2009

1. Unclip and remove the small rectangular trim around shift lever. (Figure A)
2. Unclip and remove the entire panel (including cup holders) surrounding the shift lever. (Figure B)
3. Remove (2) 9/32" screws at the bottom of the center radio/climate control panel. (Figure C)
4. Unclip and remove the center panel.(Figure D)
5. Remove (4) 9/32" screws from the radio to remove. (Figure E)

Continue to Kit Assembly

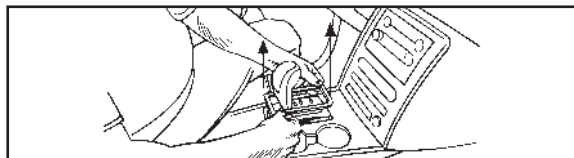

(Figure A)

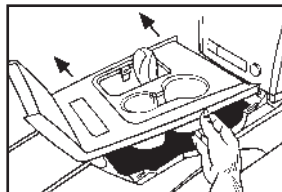

(Figure B)

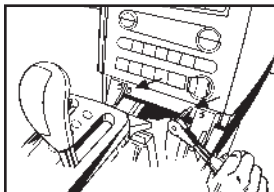

(Figure C)

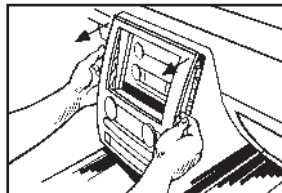

(Figure D)

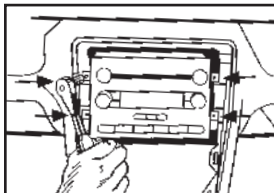

(Figure E)

Ford Fusion 2006-2009

Mercury Milan 2006-2009

1. Unsnap and remove entire panel surrounding the radio and climate controls. (Figure A)
2. Remove (4) 9/32" screws to remove the factory radio. (Figure B)

Continue to Kit Assembly

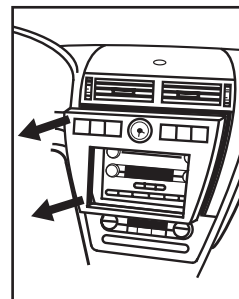

(Figure A)

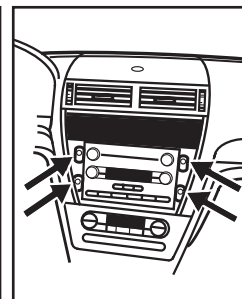

(Figure B)

DASH DISASSEMBLY

Ford Freestyle 2005-2007

Ford Taurus X 2008-2009

1. Unclip and remove entire panel surrounding the radio and A/C controls. (Figure A)
2. Remove (4) 9/32" screws from radio to remove. (Figure B)

Continue to Kit Assembly

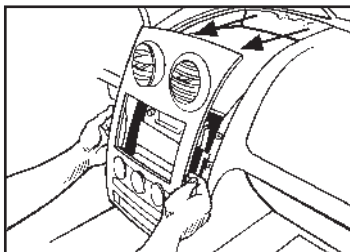

(Figure A)

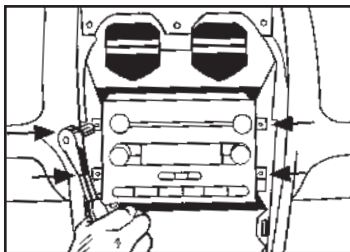

(Figure B)

Ford Freestar 2004-2007

Mercury Monterey 2004-2007

1. Unsnap and remove entire panel surrounding the radio and climate controls. (Figure A)
2. Remove (4) 9/32" screws to remove the factory radio. (Figure B)

Continue to Kit Assembly

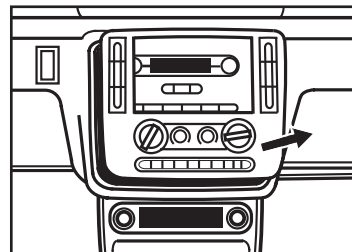

(Figure A)

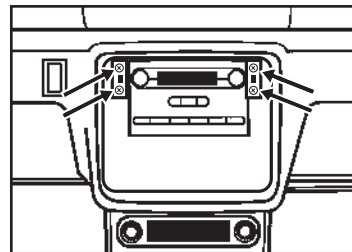

(Figure B)

DASH DISASSEMBLY

Ford Focus 2005-2007

1. Unsnap and remove entire panel surrounding the radio and climate controls. (Figure A)
2. Remove (4) 9/32" screws to remove the factory radio. (Figure B)

Continue to Kit Assembly

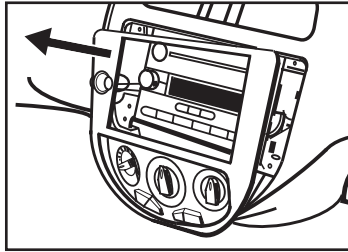

(Figure A)

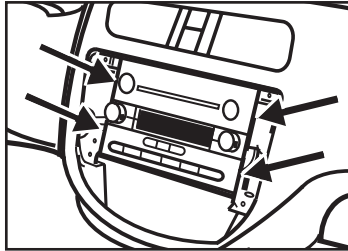

(Figure B)

Ford Explorer/Explorer Sport Trac 2006-2010 Mercury Mountaineer 2006-2010

1. Open center console and remove (2) Phillips screws then unclip and remove entire panel surrounding shifter. (Figure A)
2. Remove dash panel surrounding radio to access the factory radio screws. (Figure B)
3. Remove (4) 9/32" screws to remove the factory radio. (Figure C)

Continue to Kit Assembly

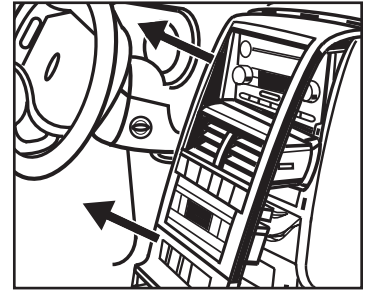

(Figure B)

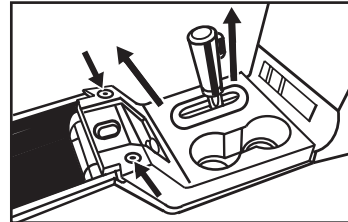

(Figure A)

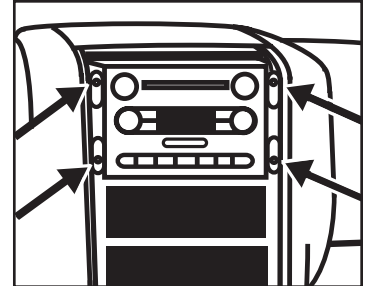

(Figure C)

DASH DISASSEMBLY

Ford Econoline (E-Series) 2009-up F-250/350/450/550 2005-2007

1. Unsnap and remove entire panel surrounding the radio and climate controls. (Figure A)
2. Remove (4) 9/32" screws to remove the factory radio. (Figure B)

Continue to Kit Assembly

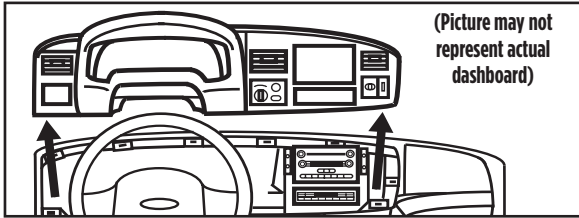

(Figure A)



(Figure B)

Ford F-250/350/450/550 2008-2012 F-250/350/450/550 (without 8" screen) 2013-2016 F-650/750 2011-up

1. Unclip and remove the power outlet panel and the blank panel on the left and right side of the radio trim panel. (Figure A)
2. Remove the (2) 9/32" screws exposed behind the two panels previously removed.
3. Unclip and remove the entire radio trim panel including the A/C control and vents.
4. Remove (4) 9/32" screws securing the radio.

Continue to Kit Assembly

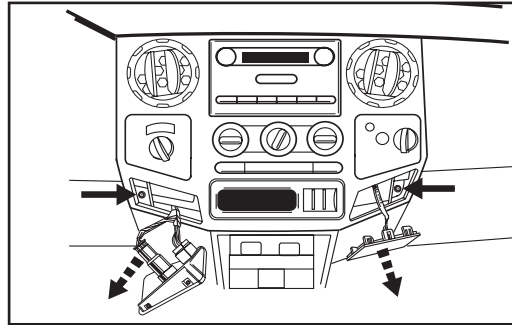

(Figure A)

Ford Transit Connect 2013 Transit Connect (late generation) 2012

1. Remove the radio trim panel. (Figure A)
2. Remove (4) screws securing the radio and then remove.

Continue to Kit Assembly

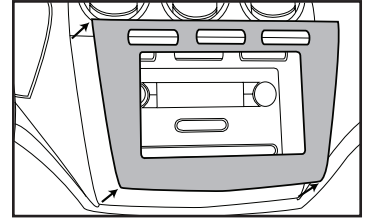

(Figure A)

DASH DISASSEMBLY

Lincoln MKX (with NAV) 2007-2010

1. Open center console lid and unclip and remove the center console trim panel surrounding the shifter. (Figure A)
2. Remove (2) Phillips screws from the storage bin then unclip and remove the bin. (Figure B)
3. Unclip and remove the upper and lower center trim panel as one assembly. (Figure C)
4. Remove (4) 9/32" screws securing the radio. Unplug and remove the radio.

Continue to Kit Assembly

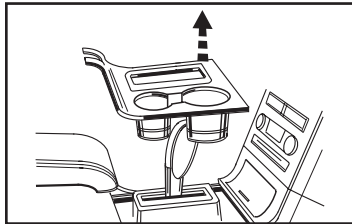

(Figure A)

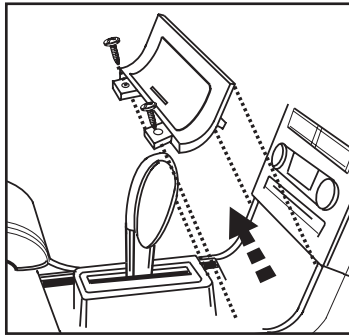

(Figure B)

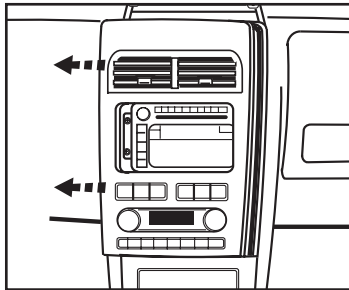

(Figure C)

Lincoln Navigator (with NAV) 2007-2014

1. Unclip and remove the panel surrounding the shifter. (Figure A)
2. Remove (2) 9/32" screws from the bottom of the radio/climate control trim panel. (Figure B)
3. Unclip and remove the entire panel surrounding the radio and including the climate controls. (Figure B)
4. Remove (4) 9/32" screws securing the radio. Unplug and remove the radio.

Continue to Kit Assembly

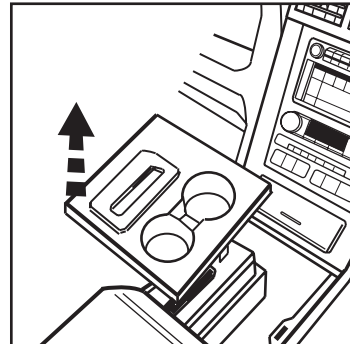

(Figure A)

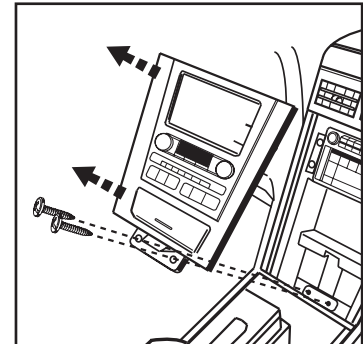

(Figure B)

KIT ASSEMBLY

DIN radio provision with pocket

- (a) For the **Ford Econoline 2009-up, Edge 2007-2010, Expedition 2007-2014, Expedition (fleet) 2015, Explorer & Explorer Sport Trac 2006-2010, F-650/750 2011-up, F-250/350/450/550 2008-2016, F-150 2004-2008, Fusion 2006-2009, Transit Connect 2012-2013 / Lincoln Mark LT 2006-2008, MKX (with NAV) 2007-2010, Navigator (with NAV) 2007-2014 / Mercury Milan 2006-2009, Mountaineer 2006-2010**, attach the **spacers** to the mounting tabs on **radio housing B**. Use the **(4) screws** provided to secure the radio housing to the vehicle. (Figure A)

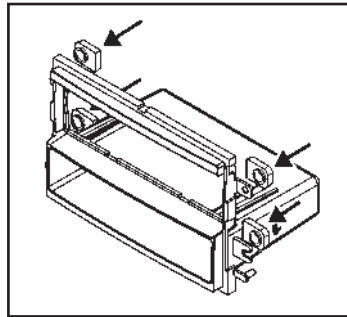

(Figure A)

- (b) For the **Ford F-250/350/450/ 550 2005-2007, Focus 2005-2007, Freestar 2004-2007, Monterey 2004-2007**, slide the **side brackets** onto the sides of **radio housing B**. (Figure B)

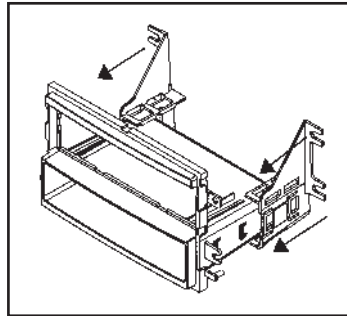

(Figure B)

Note: If your vehicle is not listed in steps (a) or (b), proceed to Step 2.

2. Remove the metal DIN sleeve from the aftermarket radio.
3. Slide the sleeve into **radio housing B** and secure by bending the metal locking tabs outward. (Figure C)
4. Slide the radio into the sleeve until it snaps in place. (Figure D)
5. Locate the factory wiring harness and antenna connection in the dash. Metra recommends using the proper mating adapter from Metra or AXXESS. Test the radio for proper operation.
6. Reassemble the dash in reverse order of disassembly.

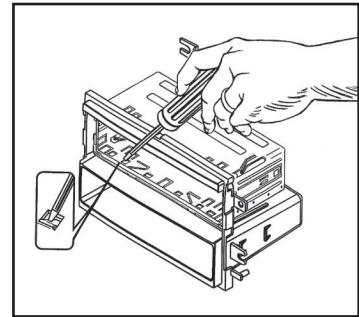

(Figure C)

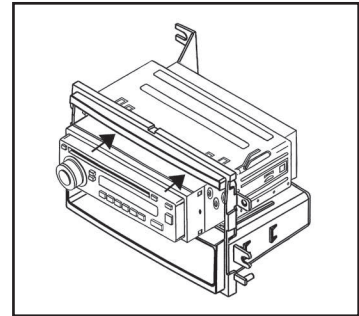

(Figure D)

KIT ASSEMBLY

ISO DIN radio provision with pocket

1. (a) For the **Ford Econoline 2009-up, Edge 2007-2010, Expedition 2007-2014, Expedition (fleet) 2015, Explorer & Explorer Sport Trac 2006-2010, F-650/750 2011-up, F-250/350/450/550 2008-2016, F-150 2004-2008, Fusion 2006-2009, Transit Connect 2012-2013 / Lincoln Mark LT 2006-2008, MKX (with NAV) 2007-2010, Navigator (with NAV) 2007-2014 / Mercury Milan 2006-2009, Mountaineer 2006-2010**, attach the **spacers** to the mounting tabs on **radio housing B**. Use the **(4) screws** provided to secure the **radio housing** to the vehicle. (Figure A)

(b) For the **Ford F-250/350/450/550 2005-2007, Focus 2005-2007, Freestar 2004-2007, Monterey 2004-2007**, slide the **side brackets** onto the sides of **radio housing B**. (Figure B)

Note: If your vehicle is not listed in steps (a) or (b), proceed to Step 2.

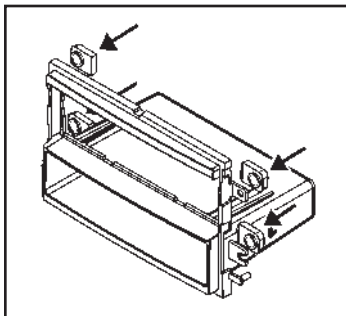

(Figure A)

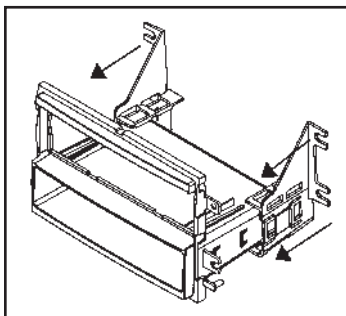

(Figure B)

2. Remove the metal DIN sleeve and trim ring from the aftermarket radio.
3. Mount the **ISO brackets** to the radio with the screws supplied with the radio. (Figure C)
4. Slide the radio into the radio opening until the side clips engage. (Figure D)
5. Snap the **trim plate** into **radio housing B**. (Figure D)
6. Locate the factory wiring harness and antenna connection in the dash. Metra recommends using the proper mating adapter from Metra or AXXESS. Test the radio for proper operation.
7. Reassemble the dash in reverse order of disassembly.

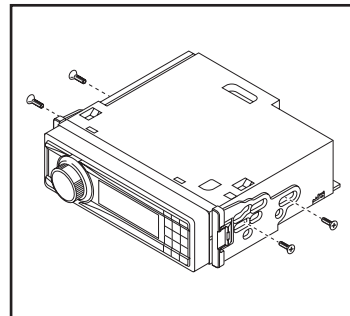

(Figure C)

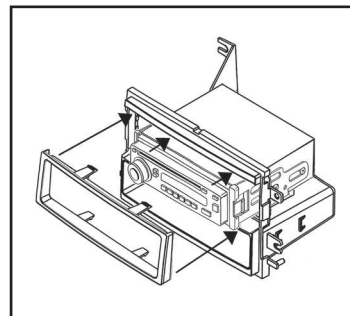

(Figure D)

KIT ASSEMBLY

ISO DDIN radio provision

1. Attach the **ISO DDIN brackets** to radio housing **A**. (Figure A)
2. (a) For the **Ford Econoline 2009-up, Edge 2007-2010, Expedition 2007-2014, Expedition (fleet) 2015, Explorer & Explorer Sport Trac 2006-2010, F-650/750 2011-up, F-250/350/450/550 2008-2016, F-150 2004-2008, Fusion 2006-2009, Transit Connect 2012-2013 / Lincoln Mark LT 2006-2008, MKX (with NAV) 2007-2010, Navigator (with NAV) 2007-2014 / Mercury Milan 2006-2009, Mountaineer 2006-2010**, attach the **spacers** to the mounting tabs on **radio housing A**. Use the **(4) screws** provided to secure the radio housing to the vehicle. (Figure B).

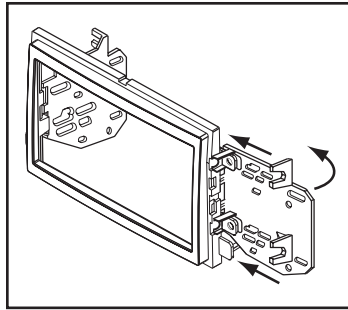

(Figure A)

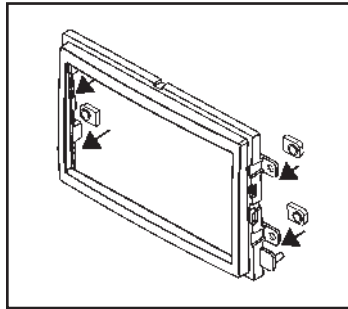

(Figure B)

- (b) For the **Ford Five Hundred 2005-2007, Freestyle 2005-2007, Mustang 2005-2009, Taurus & Taurus X 2008-2009 / Mercury Montego 2005-2007, Sable 2008-2009**, cut and remove the rear mounting tabs from the brackets. (Figure C)

Note: If your vehicle is not listed in steps (a) or (b), proceed to step 3.

3. Slide the radio into the radio housing and secure using the screws supplied with the radio. (Figure D)
4. Locate the factory wiring harness and antenna connection in the dash. Metra recommends using the proper mating adapter from Metra or AXCESS. Test the radio for proper operation.
5. Reassemble the dash in reverse order of disassembly.

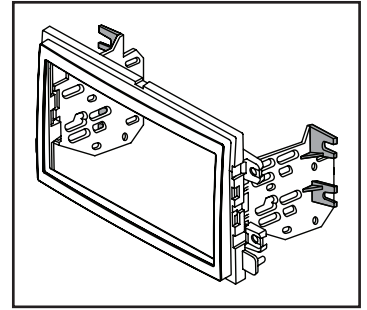

(Figure C)

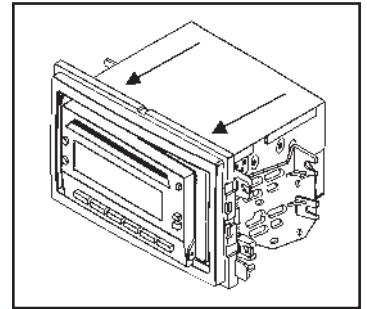

(Figure D)



95-5812 or 99-5812
INSTALLATION INSTRUCTIONS



If you are having difficulties with the installation of this product, contact our Tech Support line either by phone at **1-800-253-TECH**, or email at **techsupport@metra-autosound.com**. Before doing so, look over the instruction booklet a second time and ensure that the installation was performed exactly as the instruction booklet is stated. Have the vehicle apart and ready to perform troubleshooting steps before contacting Metra/Axxess Tech Support.



KNOWLEDGE IS POWER

Enhance your installation and fabrication skills by enrolling in the most recognized and respected mobile electronics school in our industry. Log onto www.installerinstitute.com or call 800-354-6782 for more information and take steps toward a better tomorrow.



Metra recommends MECP certified technicians



Ford/Lincoln/Mercury 2004 y mas

CARACTERÍSTICAS DEL KIT

95-5812: MetraOnline.com/part/95-5812

- Provisión de radio ISO DDIN

99-5812: MetraOnline.com/part/99-5812

- Provisión de radio DIN con bolsillo
- Provisión de radio ISO DIN con bolsillo

COMPONENTES DEL KIT

95-5812: • A1) Carcasa de radio A • B1) Soportes ISO DDIN • C1) Espaciadores • D1) (4) Tornillos

99-5812: • A2) Carcasa de radio B • B2) Soportes ISO • C2) Placa de moldura • D2) Soportes laterales • E2) Espaciadores • F2) (4) Tornillos

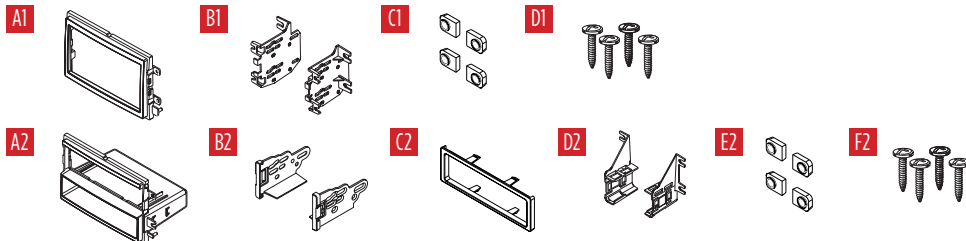

APLICACIONES

Ver lista de aplicaciones dentro de la portada

INDICE

Por favor vea dentro de la portada

CABLEADO Y CONEXIONES DE ANTENA

(se venden por separado)

Árnés de cableado: Visite metraonline.com para las opciones del árnés

Antenna Adapter: 40-CR10

HERRAMIENTAS REQUERIDAS

- Herramienta de corte
- Herramienta para quitar paneles
- Destornillador Phillips • llave de tubo

¡Precaución! Todos los accesorios, interruptores, paneles de controles de clima y especialmente las luces del indicador de las bolsas de aire deben estar conectados antes ciclar la ignición. Además, no quite el radio de fábrica con la llave en la posición o de encendido ni con el vehículo funcionando.

APLICACIONES

Ford

Econoline (E-Series).....	2009-up
Edge.....	2007-2010
Expedition	2007-2014
Expedition (flota).....	2015
Explorer	2006-2010
Explorer Sport Trac	2006-2010
F-150.....	2004-2008
F-250/350/450/550	2005-2012
F-250/350/450/550 (sin pantalla 8").....	2013-2016
F-650/750.....	2011-up
Five Hundred	2005-2007
Focus	2005-2007
Freestar	2004-2007
Freestyle	2005-2007
Fusion	2006-2009
Mustang	2005-2009
Taurus	2008-2009
Taurus X	2008-2009
Transit Connect (generación tardía).....	2012
Transit Connect.....	2013

Lincoln

Mark LT	2006-2008
MKX (con NAV).....	2007-2010
Navigator (con NAV).....	2007-2014
Mercury	
Milan	2006-2009
Mountaineer	2006-2010
Monterey	2004-2007
Montego	2005-2007
Sable	2008-2009

INDICE

Dash Disassembly

Ford

- Econoline (E-Series) 2009-up	7
- Edge 2007-2010	3
- Expedition 2007-2014	3
- Expedition (flota) 2015	3
- Explorer 2006-2010.....	6
- Explorer Sport Trac 2006-2010	6
- F-150 2004-2008.....	3
- F-250/350/450/550 2005-2012	7
- F-250/350/450/550 (sin pantalla 8") 2013-2016	7
- F-650/750 2011-up.....	7
- Five Hundred 2005-2007	4
- Focus 2005-2007	6
- Freestar 2004-2007.....	5
- Freestyle 2005-2007	5
- Fusion 2006-2009	4
- Mustang 2005-2009.....	3
- Taurus 2008-2009	4
- Taurus X 2008-2009	5
- Transit Connect (generación tardía) 2012.....	7
- Transit Connect 2013.....	7

Lincoln

- Mark LT 2006-2008.....	3
- MKX (con NAV) 2007-2010	8

Mercury

- Navigator (con NAV) 2007-2014	8
- Milan 2006-2009.....	4
- Mountaineer 2006-2010	6
- Monterey 2004-2007.....	5
- Montego 2005-2007.....	4
- Sable 2008-2009.....	4

Ensamble del kit

- Provisión de radio DIN con bolsillo.....	9
- Provisión de radio ISO DIN con bolsillo	10
- Provisión de radio ISO DDIN	11

DESMONTAJE DEL TABLERO

Ford F-150 2004-2008

Ford Edge 2007-2010

Ford Expedition 2007-2014

Ford Expedition (flota) 2015

Lincoln Mark LT 2006-2008

1. Suelte a presión y quite todo el panel que rodea el radio y los controles del clima. (Figura A)
2. Quite los (4) tornillos de 9/32" para quitar el radio de fábrica. (Figura B)

Continúe con el Ensamble del Kit

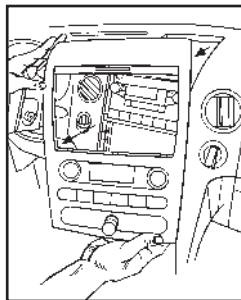

(Figura A)

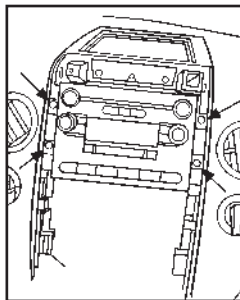

(Figura B)

Ford Mustang 2005-2009

1. Quite el pequeño panel de la moldura de la palanca de velocidades si se incluye. (Figura A)
2. Quite los (2) tornillos Phillips de debajo del descansabrazos central en la parte posterior del panel de la moldura de la palanca de velocidades (incluyendo los portavasos). (Figura B)
3. Desenganche y quite el panel. (Figura B)
4. Desenganche y quite los (2) paneles de moldura de la pila central del lado izquierdo y derecho del radio de fábrica y los controles del clima. (Figura C)
5. Quite los (6) tornillos de 9/32" del panel de moldura central que rodea el radio y los controles del clima y luego desenganche y quite el panel. (Figura D)
6. Quite los (4) tornillos de 9/32" del radio para quitarlo. (Figura E)

Continúe con el Ensamble del Kit

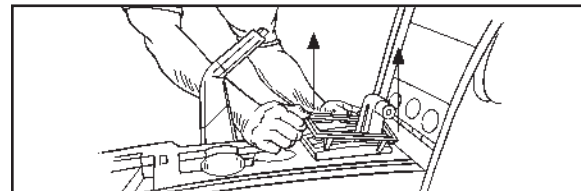

(Figura A)

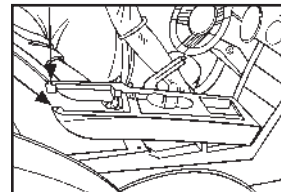

(Figura B)

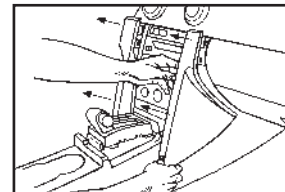

(Figura C)

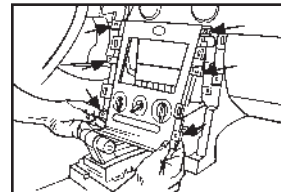

(Figura D)

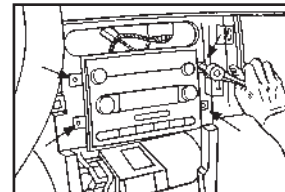

(Figura E)

DESMONTAJE DEL TABLERO

Ford Five Hundred 2005-2007

Ford Taurus 2008-2009

Mercury Montego 2005-2007

Mercury Sable 2008-2009

1. Desenganche y quite la pequeña moldura rectangular que rodea la palanca de velocidades. (Figura A)
2. Desenganche y quite todo el panel (incluyendo los portavasos) que rodea la palanca de velocidades. (Figura B)
3. Quite los (2) tornillos de 9/32" de la parte inferior del panel central de control del radio/clima. (Figura C)
4. Desenganche y quite el panel central. (Figura D)
5. Quite los (4) tornillos de 9/32" del radio para quitarlo. (Figura E)

Continúe con el Ensamble del Kit

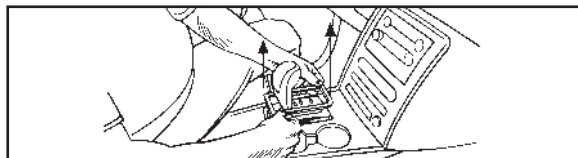

(Figura A)

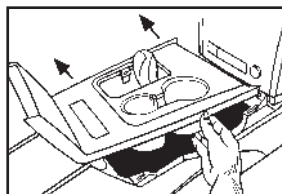

(Figura B)

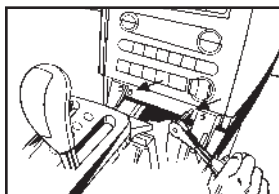

(Figura C)

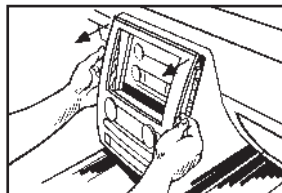

(Figura D)

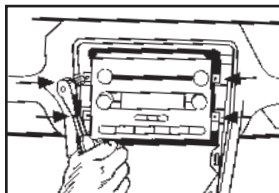

(Figura E)

Ford Fusion 2006-2009

Mercury Milan 2006-2009

1. Suelte a presión y quite todo el panel que rodea el radio y los controles del clima. (Figura A)
2. Quite los (4) tornillos de 9/32" para quitar el radio de fábrica. (Figura B)

Continúe con el Ensamble del Kit

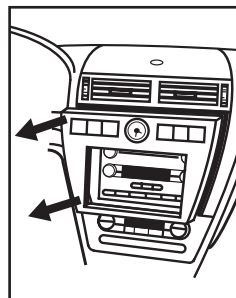

(Figura A)

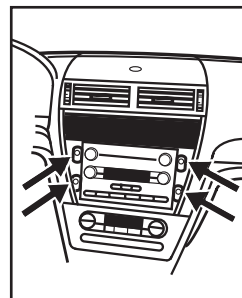

(Figura B)

DESMONTAJE DEL TABLERO

Ford Freestyle 2005-2007

Ford Taurus X 2008-2009

1. Soltar y retirar todo el panel que rodea la radio y los controles de A/C. (Figura A)
2. Quite los (4) tornillos de 9/32" del radio para quitarlo. (Figura B)

Continúe con el Ensamble del Kit

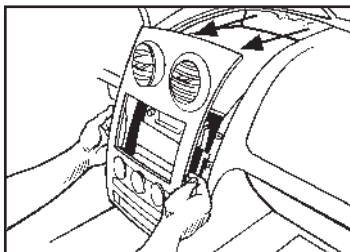

(Figura A)

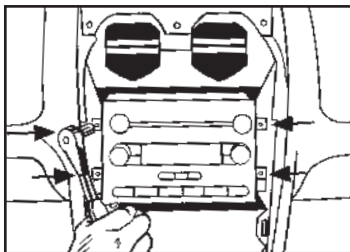

(Figura B)

Ford Freestar 2004-2007

Mercury Monterey 2004-2007

1. Suelte a presión y quite todo el panel que rodea el radio y los controles del clima. (Figura A)
2. Quite los (4) tornillos de 9/32" para quitar el radio de fábrica. (Figura B)

Continúe con el Ensamble del Kit

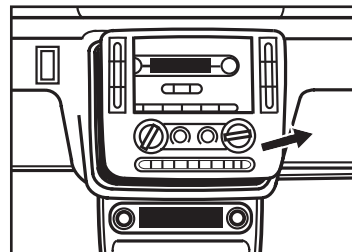

(Figura A)

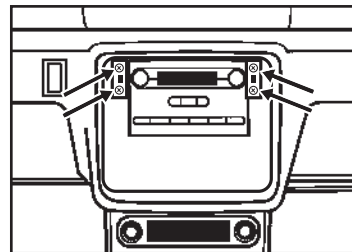

(Figura B)

DESMONTAJE DEL TABLERO

Ford Focus 2005-2007

1. Suelte a presión y quite todo el panel que rodea el radio y los controles del clima. (Figura A)
2. Quite los (4) tornillos de 9/32" para quitar el radio de fábrica. (Figura B)

Continúe con el Ensamble del Kit

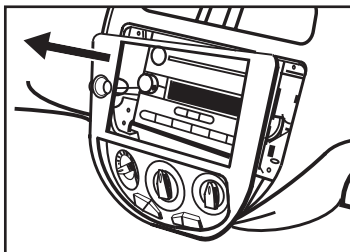

(Figura A)

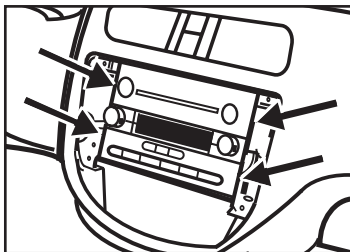

(Figura B)

Ford Explorer/Explorer Sport Trac 2006-2010 Mercury Mountaineer 2006-2010

1. Abra la consola central y retire los (2) tornillos Phillips, luego desenganche y quite todo el panel que rodea la palanca de velocidades. (Figura A)
2. Quite el panel del tablero que rodea el radio para tener acceso a los tornillos del radio de fábrica. (Figura B)
3. Quite los (4) tornillos de 9/32" para quitar el radio de fábrica. (Figura C)

Continúe con el Ensamble del Kit

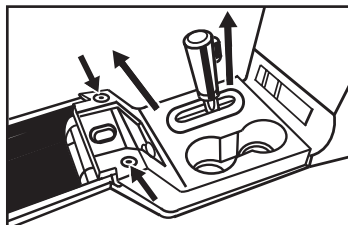

(Figura A)

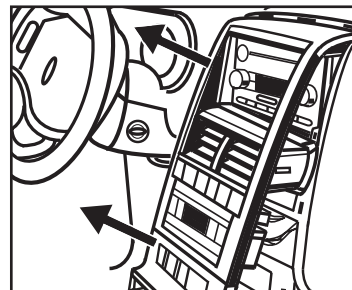

(Figura B)

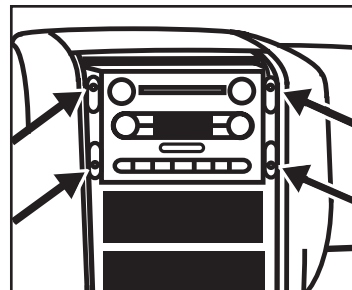

(Figura C)

DESMONTAJE DEL TABLERO

Ford Econoline (E-Series) 2009 y mas F-250/350/450/550 2005-2007

1. Suelte a presión y quite todo el panel que rodea el radio y los controles del clima. (Figura A)
2. Quite los (4) tornillos de 9/32" para quitar el radio de fábrica. (Figura B)

Continúe con el Ensamble del Kit

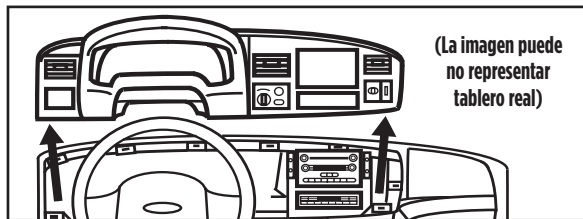

(Figura A)



(Figura B)

Ford F-250/350/450/550 2008-2012 F-250/350/450/550 (in pantalla 8") 2013-2016 F-650/750 2011 y mas

1. Desenganche y quite el panel del tomacorriente y el panel de tapa del lado izquierdo y derecho del panel de la moldura del radio. (Figura A)
2. Quite los (2) tornillos de 9/32" expuestos detrás de los dos paneles que quitó anteriormente.
3. Desenganche y quite todo el panel de la moldura del radio, incluyendo el control y las rejillas del aire acondicionado.
4. Quite los (4) tornillos de 9/32" que sujetan el radio.

Continúe con el Ensamble del Kit

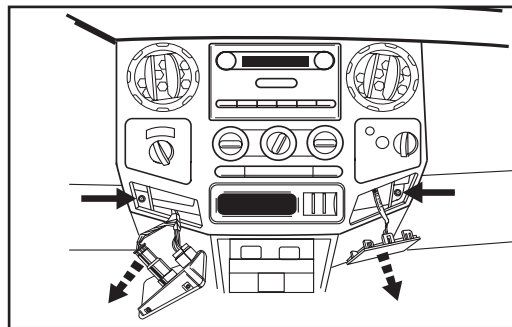

(Figura A)

Ford Transit Connect 2013 Transit Connect (late generation) 2012

1. Quite el panel de la moldura del radio. (Figura A)
2. Quite los (4) tornillos que sujetan de radio y quite.

Continúe con el Ensamble del Kit

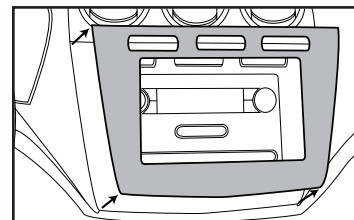

(Figura A)

DESMONTAJE DEL TABLERO

Lincoln MKX (con NAV) 2007-2010

1. Abra la tapa de la consola central y desenganche y quite el panel de la moldura de la consola central que rodea la palanca de velocidades. (Figura A)
2. Quite los (2) tornillos Phillips del cajón de almacenamiento y luego desenganche y quite el cajón. (Figura B)
3. Desenganche y quite el panel superior e inferior de la moldura central como un mismo ensamble. (Figura C)
4. Quite los (4) tornillos de 9/32" que sujetan el radio. Desconecte y quite el radio.

Continúe con el Ensamble del Kit

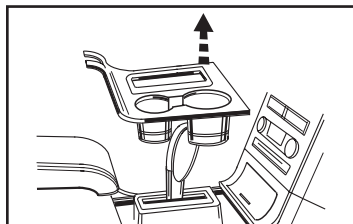

(Figura A)

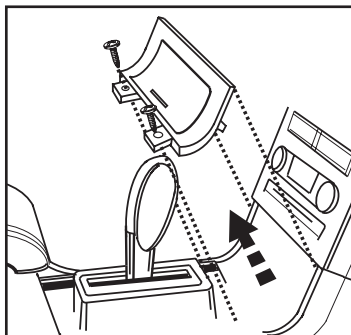

(Figura B)

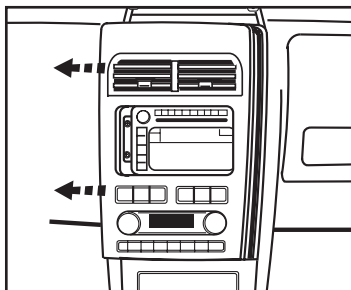

(Figura C)

Lincoln Navigator (con NAV) 2007-2014

1. Desenganche y quite el panel que rodea la palanca de velocidades. (Figura A)
2. Quite los (2) tornillos de 9/32" de la parte inferior del panel de la moldura de control del radio/clima. (Figura B)
3. Desenganche y quite todo el panel que rodea el radio, incluyendo los controles del clima. (Figura B)
4. Quite los (4) tornillos de 9/32" que sujetan el radio. Desconecte y quite el radio.

Continúe con el Ensamble del Kit

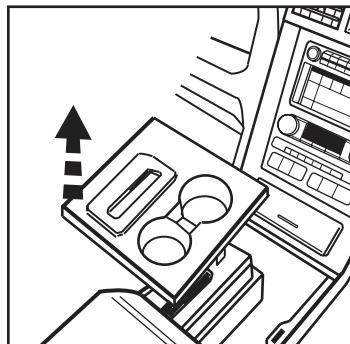

(Figura A)

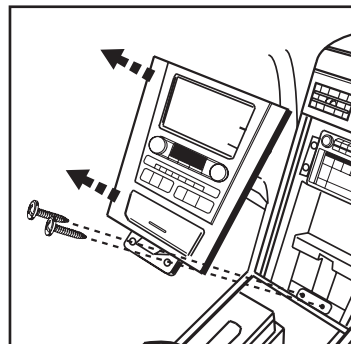

(Figura B)

ENSAMBLE DEL KIT

DIN radio provision with pocket

1. (a) Para el **Ford Econoline 2009 y mas, Edge 2007-2010, Expedition 2007-2014, Expedition (flota) 2015, Explorer & Explorer Sport Trac 2006-2010, F-650/750 2011 y mas, F-250/350/450/550 2008-2016, F-150 2004-2008, Fusion 2006-2009, Transit Connect 2012-2013 / Lincoln Mark LT 2006-2008, MKX (con NAV) 2007-2010, Navigator (con NAV) 2007-2014 / Mercury Milan 2006-2009, Mountaineer 2006-2010**, acople los **separadores** incluidos para las lengüetas de montaje en la **carcasa del radio B**. Use los **(4) tornillos** suministrados para montar la carcasa al radio del vehículo. (Figura A)

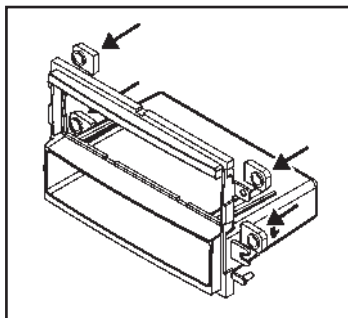

(Figura A)

- (b) Para el **Ford F-250/350/450/ 550 2005-2007, Focus 2005-2007, Freestar 2004-2007, Monterey 2004-2007**, deslice los **soportes laterales** en los lados de la **carcasa del radio B**. (Figura B)

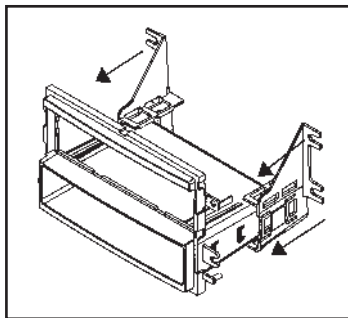

(Figura B)

Nota: Si su vehículo no aparece en las etapas (a) o (b), vaya al paso 2.

2. Quite la manga de metal DIN del radio de mercado secundario.
3. Deslice la manga en la **carcasa del radio B** y sujétela doblando hacia abajo las pestañas de metal. (Figura C)
4. Deslice el radio en la manga hasta que entre a presión. (Figura D)
5. Localice el arnés de cables de fábrica en el tablero. Metra recomienda el uso de un adaptador adecuado de acoplamiento de Metra o de AXCESS. Test the radio for proper operation.
6. Vuelva a armar el tablero al revés de como lo desarmó.

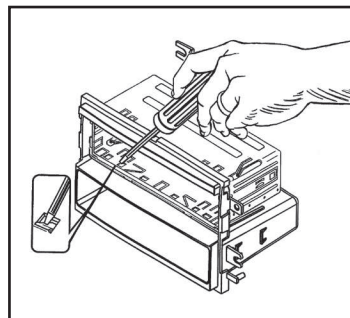

(Figura C)

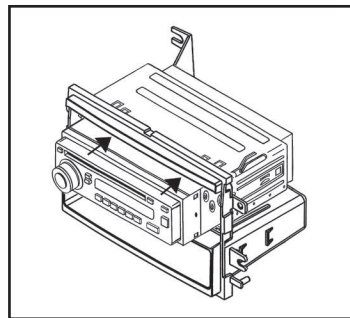

(Figura D)

ENSAMBLE DEL KIT

Provisión de radio ISO DIN con bolsillo

1. (a) Para el **Ford Econoline 2009 y mas, Edge 2007-2010, Expedition 2007-2014, Expedition (flota) 2015, Explorer & Explorer Sport Trac 2006-2010, F-650/750 2011 y mas, F-250/350/450/550 2008-2016, F-150 2004-2008, Fusion 2006-2009, Transit Connect 2012-2013 / Lincoln Mark LT 2006-2008, MKX (con NAV) 2007-2010, Navigator (con NAV) 2007-2014 / Mercury Milan 2006-2009, Mountaineer 2006-2010**, acople los **separadores** incluidos para las lengüetas de montaje en la **carcasa del radio B**. Use los **(4) tornillos** suministrados para montar la **carcasa de la radio** del vehículo. (Figura A)

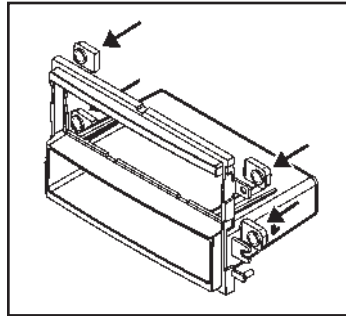

(Figura A)

- (b) Para el **Ford F-250/350/450/550 2005-2007, Focus 2005-2007, Freestar 2004-2007, Monterey 2004-2007**, deslice los **soportes laterales** en los lados de la **carcasa del radio B**. (Figura B)

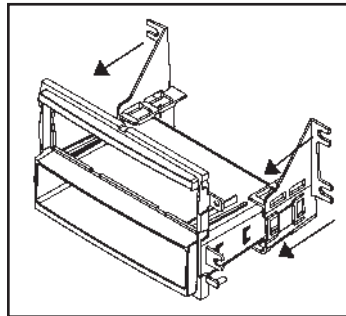

(Figura B)

Nota: Si su vehículo no aparece en las etapas (a) o (b), vaya al paso 2.

2. Quite la manga de metal DIN y el anillo de moldura del radio de mercado secundario.
3. Monte los **soportes ISO** en el radio con los tornillos que vienen con el radio. (Figura C)
4. Deslice la radio en la abertura de radio hasta que los ganchos laterales se acoplan. (Figura D)
5. Coloque la placa de ajuste en la **carcasa del radio B**. (Figura D)
6. Localice el arnés de cables de fábrica en el tablero. Metra recomienda el uso de un adaptador adecuado de acoplamiento de Metra o de AXCESS. Test the radio for proper operation.
7. Vuelva a armar el tablero al revés de como lo desarmó.

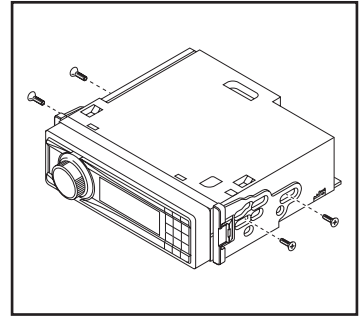

(Figura C)

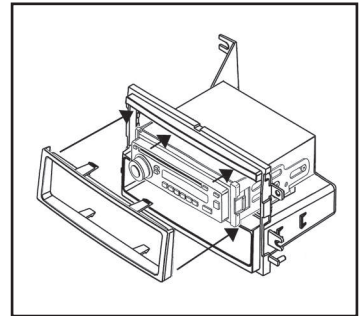

(Figura D)

ENSAMBLE DEL KIT

Provisión de radio ISO DDIN

1. Conecte los **soportes ISO DDIN** a la **carcasa de radio A**. (Figura A)
2. (a) Para el **Ford Econoline 2009 y mas, Edge 2007-2010, Expedition 2007-2014, Expedition (flota) 2015, Explorer & Explorer Sport Trac 2006-2010, F-650/750 2011-up, F-250/350/450/550 2008-2016, F-150 2004-2008, Fusion 2006-2009, Transit Connect 2012-2013 / Lincoln Mark LT 2006-2008, MKX (con NAV) 2007-2010, Navigator (con NAV) 2007-2014 / Mercury Milan 2006-2009, Mountaineer 2006-2010**, fije los **espaciadores** a las lengüetas de montaje en la **carcasa del radio A**. Utilice los **(4) tornillos** provistos para asegurar la carcasa del radio al vehículo. (Figura B).

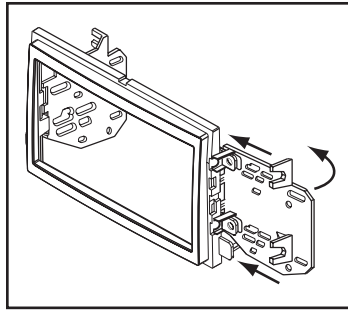

(Figura A)

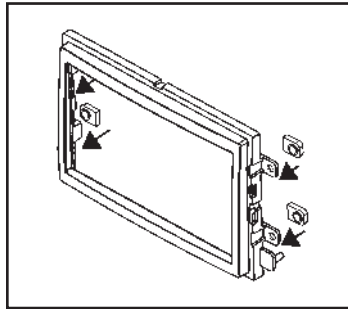

(Figura B)

- (b) Para el **Ford Five Hundred 2005-2007, Freestyle 2005-2007, Mustang 2005-2009, Taurus & Taurus X 2008-2009 / Mercury Montego 2005-2007, Sable 2008-2009**, corte y retire las lengüetas de montaje traseras de los soportes. (Figura C)

Nota: Si su vehículo no aparece en las etapas (a) o (b), vaya al paso 2.

3. Deslice la radio en la **carcasa del radio B** y asegure utilizando los tornillos suministrados con la radio. (Figura C)
4. Localice el arnés de cables de fábrica en el tablero. Metra recomienda el uso de un adaptador adecuado de acoplamiento de Metra o de AXCESS. Test the radio for proper operation.
5. Vuelva a armar el tablero al revés de como lo desarmó.

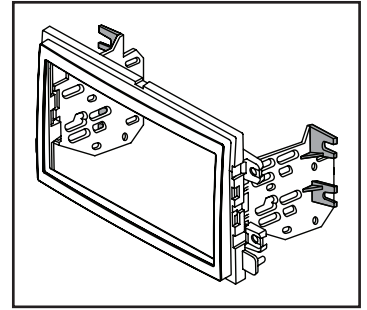

(Figura C)

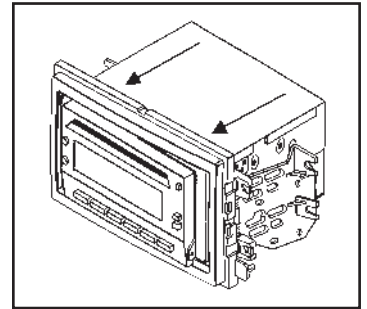

(Figura D)



95-5812 or 99-5812
INSTRUCCIONES DE INSTALACIÓN



Si tiene dificultades con la instalación de este producto, comuníquese con nuestra línea de soporte técnico, ya sea por teléfono al **1-800-253-TECH**, o envíe un correo electrónico a **techsupport@metra-autosound.com**. Antes de hacerlo, revise el folleto de instrucciones por segunda vez y asegúrese de que la instalación se realizó exactamente como se indica en el manual de instrucciones. Tenga el vehículo separado y listo para realizar los pasos de solución de problemas antes de ponerse en contacto con el soporte técnico de Metra / Axxess.



EL CONOCIMIENTO ES PODER
Mejore sus habilidades de instalación y fabricación inscribiéndose en la escuela de dispositivos electrónicos móviles más reconocida y respetada de nuestra industria. Regístrese en www.installerinstitute.com o llame al 800-354-6782 para obtener más información y avance hacia un futuro mejor.



Metra recomienda técnicos con certificación del Programa de Certificación en Electrónica Móvil (Mobile Electronics Certification Program, MECP).