



Porsche (with MOST 25 amplifier) Data Interface with SWC 2009-2012*

*PCM3.0 Radio

INTERFACE FEATURES

- Designed for MOST*25 amplified systems
- Provides accessory power (12-volt)
- Retains audio controls on the steering wheel controls
- Easy to set Dipswitches for SWC configuration
- Provides NAV outputs (parking brake, reverse, and speed sense)
- Micro B USB updatable

* Media Oriented System Transport

INTERFACE COMPONENTS

- AXDIS-P062 interface
- AXDIS-P062 harness

APPLICATIONS

Porsche

911 Coupe (997).....	2009-2012
Boxster (987).....	2009-2011
Caymen (987).....	2009-2012

MetraOnline.com may be used to assist with dash assembly instructions. Simply enter your Year, Make, Model vehicle into the vehicle fit guide and look for the Dash Kit Installation Instructions.

www.MetraOnline.com



Product Info



TABLE OF CONTENTS

Connections: BLK-AXDIS-P062 Harness.....	2
SWC Chart (Steering Wheel Control).....	3
Installing the AXDIS-P062 Interface	4
Installing the Fiber Optic Cable.....	5

Visit AxxessInterfaces.com for more detailed information about the product and up-to-date vehicle specific applications

TOOLS REQUIRED

- Wire cutter
- Crimp tool and connectors (example: butt-connectors, bell caps, etc.)
- Solder gun, solder, heat shrink
- Tape
- Zip ties

ATTENTION: With the key out of the ignition, disconnect the negative battery terminal before installing this product. Ensure that all installation connections, especially the air bag indicator lights, are plugged in before reconnecting the battery or cycling the ignition to test this product.

NOTE: Refer also to the instructions included with the aftermarket accessory before installing this device.

CONNECTIONS: BLK-AXDIS-PO62 HARNESS

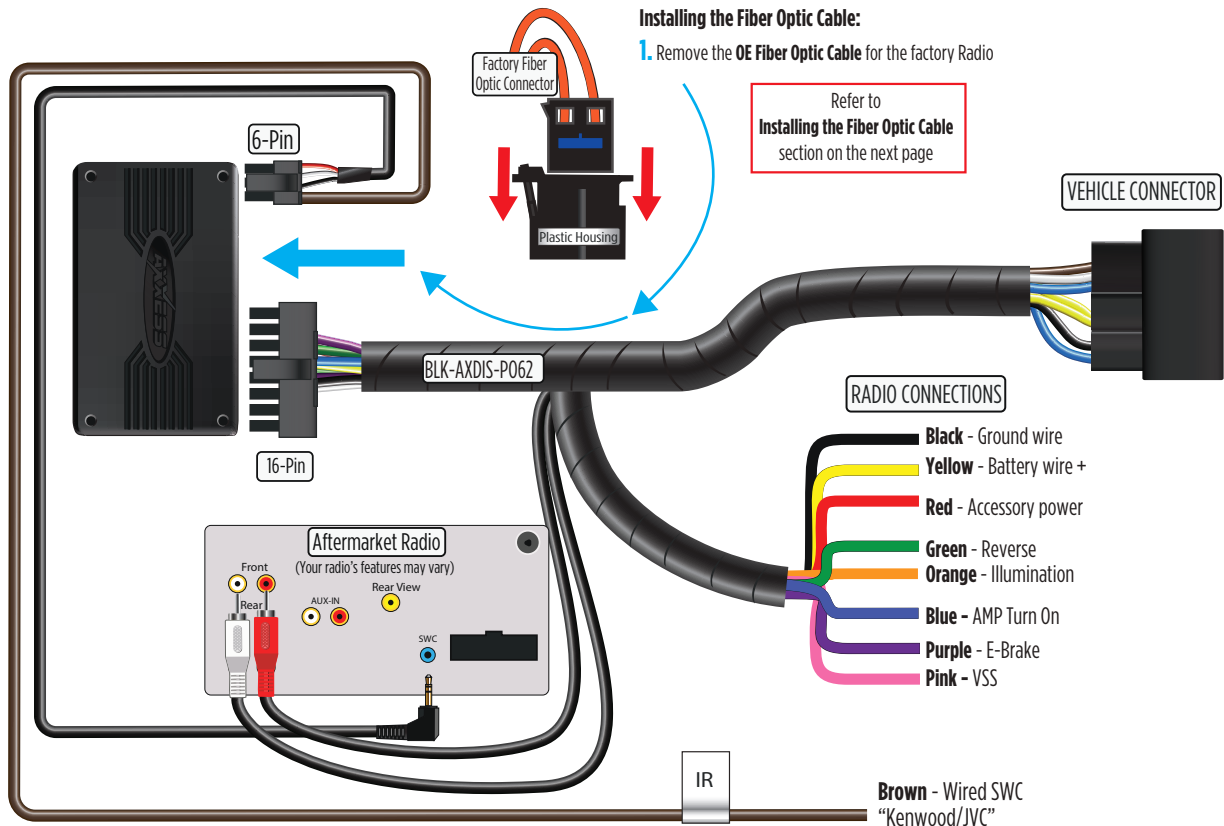

SWC CHART

Applicable Radio: PCM3.0

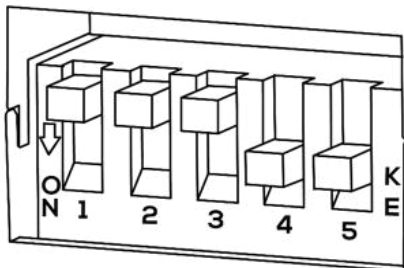

Press dipswitch in to the down position to turn ON.
Pioneer 1 example shown in the diagram.

Metra MOST Interface Dipswitch Table							
MFR	System	DIP Switch Settings					Additional Comments
		1	2	3	4	5	
RESERVED	NA	OFF	OFF	OFF	OFF	OFF	SW UPDATE MODE
ALPINE	IR DATA	OFF	ON	OFF	OFF	OFF	
AXXERA 2	IR DATA	ON	ON	OFF	OFF	OFF	
CLARION 1	IR DATA	ON	OFF	OFF	ON	OFF	
CLARION 2	IR DATA	ON	ON	OFF	ON	OFF	
DUAL	Analog	OFF	OFF	ON	ON	OFF	
GRUNDIG	IR DATA	OFF	ON	OFF	ON	OFF	
JENSEN	Analog	OFF	OFF	OFF	ON	ON	
JVC	IR DATA	OFF	OFF	ON	OFF	OFF	BROWN WIRED SWC
KENWOOD 1	IR DATA	ON	OFF	OFF	OFF	OFF	BROWN WIRED SWC
KENWOOD 2	IR DATA	ON	ON	OFF	OFF	OFF	BROWN WIRED SWC
LG 1	Analog	OFF	OFF	ON	ON	OFF	
LG 2	IR DATA	OFF	ON	ON	OFF	OFF	
PHILIPS 1	IR DATA	ON	OFF	ON	ON	OFF	
PHILIPS 2	IR DATA	OFF	ON	OFF	ON	OFF	
PIONEER 1	Analog	OFF	OFF	OFF	ON	ON	MALE 3.5MM JACK
PIONEER 2	Analog	OFF	OFF	OFF	ON	OFF	MALE 3.5MM JACK
SONY	Analog	OFF	OFF	ON	ON	OFF	MALE 3.5MM JACK
VALOR	IR DATA	ON	OFF	ON	OFF	OFF	
SPARE	IR DATA	OFF	ON	ON	ON	OFF	
SPARE	Analog	ON	ON	ON	OFF	OFF	
SPARE	Analog	ON	ON	ON	ON	OFF	

INSTALLING THE AXDIS-PO62 INTERFACE

Installing the AXDIS-PO62 interface

With the key in the off position:

1. Connect **male 3.5mm jack** to the steering wheel control port on the radio.
2. Ensure that the dipswitches are set to the desired radio type. Refer to **SWC Chart** on page 3.
3. Connect the **AXDIS-PO62 harness** to the **AXDIS-PO62 interface**.
4. Remove the **dust cover** from the optic port on the **AXDIS-PO62 interface**.
5. Connect the factory **fiber optic cable** to the **AXDIS-PO62 interface**.
6. Connect the **AXDIS-PO62 harness** to the **wiring harness** in the vehicle.
7. Turn on the ignition and test all features.

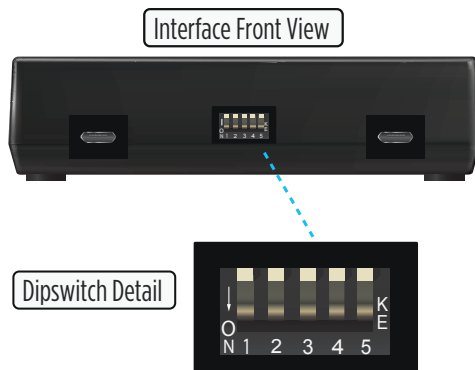

NOTE: For Dipswitch Settings for your Radio Type, refer to **SWC Chart** on page 3.

INSTALLING THE FIBER OPTIC CABLE

Installing the Fiber Optic Cable:

Removal of the original fiber optic connection is required to adapt to the Media Oriented System Transport (MOST) interface.

- Seat the AXDIS-P062 amplifier interface in the black connector housing provided with this kit and snap the housing in place. (Figure A)
- From the original Fiber Optic Connector: Using a pick tool, carefully pull this tab towards the outside edge for the connector housing. Gently remove the gray fiber optic insert from the connector. (Figure B)
- From the MOST Interface: Push the tab toward the gray dust cover and, using a needle nose plier, remove the gray dust cover. Replace the gray connector with the factory fiber optic cables into the MOST interface's black connector housing. (Figure C)



(Figure A)

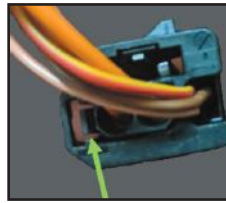

(Figure B)



(Figure C)



AXDIS-P062

INSTALLATION INSTRUCTIONS

Having difficulties? We're here to help.



Contact our Tech Support line at:

1-386-257-1187



Or via email at:

techsupport@metra-autosound.com

Tech Support Hours (Eastern Standard Time)

Monday - Friday: 9:00 AM - 7:00 PM

Saturday: 10:00 AM - 5:00 PM

Sunday: 10:00 AM - 4:00 PM



**Metra recommends MECP
certified technicians**