



AGA eR7

Model No's: eR7 100-3 and eR7 150-5

User Guide & Installation Instructions

REMEMBER, when replacing a part on this appliance, use only spare parts that you can be assured conform to the safety and performance specification that we require.

DO NOT use reconditioned or copy parts that have not been clearly authorised by AGA.



**PLEASE READ THESE INSTRUCTIONS BEFORE USING THIS APPLIANCE
AND KEEP IN A SAFE PLACE FOR FUTURE REFERENCE.**



For use in USA & CAN

Make a note of your AGA eR7 Serial Number when it is being installed. The serial number can be found behind the magnetic plinth cover.

My AGA Details:

Serial No: _____

AGA Service No: _____



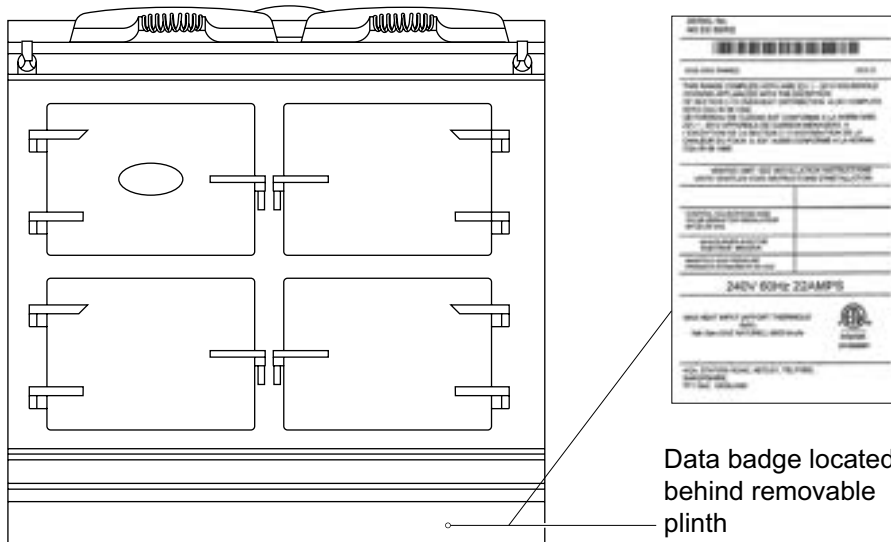

Date of Installation: _____

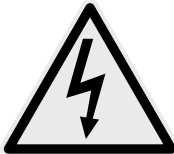

Contents

1. Product Safety	1	19. AGA (Hotcupboard)	30
2. Health & Safety	3	20. Fitting and removing the oven doors	31
3. Introduction	5	21. Cleaning & Caring for your Range32	
4. Overview	6	22. Servicing and warranty	34
5. How to use your AGA eR7	8	23. Installation Instructions	35
Getting started	9	24. Installation requirements	36
Operating the hobs	9	25. Location	37
6. Cooking on your AGA eR7	12	26. Clearances	38
7. General advice	13	27. Appliance dimensions	40
8. Handset – A hand held control	14	28. Connection to the Power Supply	42
Screens	14	AGA Hotcupboard connections	44
Button operations	14	29. Mains Supply Location	45
9. Handset advice	15	Mains cable routing	45
10. Communication/handshake	16	Mains cable routing- AGA Hotcupboard	46
11. The date/time setting screen	17	30. Hotcupboard installation	47
12. Auto/events programme screen	18	31. Circuit Diagram	54
13. Information (home) screen	19		
14. Batteries	20		
15. Equipment supplied with your AGA eR7	21		
16. Fitting the Oven Shelves	23		
17. Removing the Oven Shelves	24		
18. Using the zones of the AGA eR7	25		
The Plates	25		
The roasting oven	27		
The baking oven	28		
The simmering oven	28		
The simmering oven	29		

1. Product Safety

Meaning / Description	Symbol	Signification / Description
<p>WARNING / CAUTION</p> <p>An appropriate safety instruction should be followed or caution to a potential hazard exists.</p>		<p>AVERTISSEMENT</p> <p>Une consigne de sécurité appropriée doivent être suivies ou garde d'un danger potentiel exists.</p>
<p>DANGEROUS VOLTAGE</p> <p>To indicate hazards arising from dangerous voltages.</p>		<p>TENSION DANGEREUSE</p> <p>Pour indiquer les dangers résultant des tensions dangereuses.</p>
<p>PROTECTIVE EARTH (GROUND)</p> <p>To identify any terminal which is intended for connection to an external conductor for protection against electric shock in case of a fault, or the terminal of a protective earth (ground) electrode.</p>		<p>TERRE DE PROTECTION</p> <p>Pour marquer bornes destinées à être raccordées à un conducteur de protection extérieur contre les chocs électiques en cas de défaut d'isolement, ou pour marquer la borne de la terre de protection.</p>
<p>HEAVY</p> <p>This product is heavy and reference should be made to the safety instructions for provisions of lifting and moving.</p>		<p>LOURD</p> <p>Ce produit est lourd et doit être fait référence aux consignes de sécurité relatives aux dispositions de soulever et déplacer.</p>
<p>DISCONNECT MAINS SUPPLY</p> <p>Disconnect incoming supply before inspection or maintenance.</p>		<p>APPAREIL À LASER DE CLASSE 2</p> <p>Alimentation d'entrée Débrancher avant inspection ou d'entretien.</p>
<p>REFER TO MANUAL</p> <p>Refer to relevant instructions detailed within the product manual.</p>		<p>ATTENTION, SURFACE TRÈS CHAUDE</p> <p>Reportez-vous aux instructions applicables, indiquées dans le manuel du produit.</p>

Important Safety Instructions



INCORRECT USE OF THIS RANGE CAN INCREASE THE RISK OF FIRE, ELECTRIC SHOCKS OR INJURY TO PERSONS.

PLEASE READ THE FOLLOWING PRECAUTIONS TO REDUCE THESE RISKS.

This appliance is not intended for use by persons (including children) with reduced physical, sensory or mental capabilities, or lack of experience and knowledge, unless they have been given supervision or instruction concerning use of the appliance by a person responsible for their safety.

ALWAYS



Always make sure children are never left alone or unsupervised when the range is on.

Always be aware that range surfaces will be hot during and after use and can cause burns.

Always teach children that the range and utensils can be hot.

Always allow heavy and hot utensils to cool in a safe place and out of reach of small children.

Always be aware hot grease is flammable. Wipe off any grease deposits on the range top and front.

In the event of a grease fire, do not remove the pan, cover the pan to extinguish the flame.

Always turn utensil handles inwards but not cover adjacent heated surfaces, to prevent accidental spillage and burns.

Always when opening an oven door, allow hot air and steam to escape.

Always use dry pot holders. Moist pot holder will cause steam burns. Do not use towels or other cloths near the heated plates.

Always clean ventilation hoods frequently, grease should not be allowed to accumulate in hood and filters.

Always make sure cabinet and work surface are capable of supporting heavy cooking utensils used on your range.

Always make sure cooking utensils are suitable for range top service. Only certain types of glass, glass ceramic earthenware/glazed utensils with stand sudden temperature changes without breaking.

Always make sure your appliance is properly installed and grounded by a qualified technician.

Always make sure your appliance is serviced by a qualified technician.



NEVER

Never store items of interest to children above the range.

Never allow children to climb on, sit or stand on any part of the range.

Never allow children to play with the controls or any part of the range.

Never wear loose fitting clothing or other flammable materials that could contact hot surfaces on the range.

Never leave boiling pans unattended, boil over causes smoking and greasy spillovers may ignite.

Never store gasoline or other volatile liquids in the range or in cabinets above or near the range, which can catch fire or explode.

Never use water on grease fires. Smother fire or flame or use a dry chemical or foam type extinguisher.

Never use your appliance for warming or heating the room.

Never repair or replace any part of the appliance unless recommended in this manual. All other servicing should be carried out by a qualified technician.

Never cover or restrict the air flow to the controls compartment.

Never install cabinets (shelves) or similar above the range with a depth greater than 13" (330mm).

Never heat unopened food containers. Pressure build-up may cause the container to burst and cause injury.

Never reach directly into a hot oven to add or remove cooking utensils. Instead pull the grid shelf out to its maximum projection.

Never use a steam cleaner to clean your range.

Never use a power spray or oven cleaners on the control panel.

Never use caustic cleaners, abrasive pads or metal scrapers to clean enamel surfaces.

2. Health & Safety

Consumer Protection

As a responsible manufacturer, we take care to make sure that our products are designed and constructed to meet the required safety standards when properly installed and used.

NOTE: The installation manual and user guide for this appliance are available online on www.agaliving.com.



INCORRECT USE OF THIS RANGE CAN INCREASE THE RISK OF FIRE, ELECTRIC SHOCKS OR INJURY TO PERSONS.

PLEASE READ THE FOLLOWING PRECAUTIONS TO REDUCE THESE RISKS.

- This appliance is not intended for use by persons (including children) with reduced physical, sensory or mental capabilities, or lack of experience and knowledge, unless they have been given supervision or instruction concerning use of the appliance by a person responsible for their safety.
- Children should be supervised to ensure that they do not play with the appliance.
- **PLEASE READ THE ACCOMPANYING WARRANTY.** Any alteration that is not approved by AGA could invalidate the approval of the appliance, operation of the warranty and could also affect your statutory rights.
- **YOUNG CHILDREN SHOULD BE KEPT AWAY FROM THE APPLIANCE AS SURFACES CAN BECOME HOT TO TOUCH.**



ALWAYS

- Children are more sensitive to heat than adults.
- Always make sure children are never left alone or unsupervised when the range is on.
- Always be aware that range surfaces will be hot during and after use and can cause burns.
- Always teach children that the range and utensils can be hot.
- Always allow heavy and hot utensils to cool in a safe place and out of reach of small children.
- Always be aware hot grease is flammable. Wipe off any grease deposits on the range top and front.
- Do not leave containers of cooking fat around the range.
- In the event of a grease fire, do not remove the pan, cover the pan to extinguish the flame.

- Always turn utensil handles inwards but not cover adjacent heated surfaces, to prevent accidental spillage and burns.
- Always when opening an oven door, allow hot air and steam to escape.
- Always use dry pot holders. Moist pot holder will cause steam burns. Do not use towels or other cloths near the heated plates.
- Always clean ventilation hoods frequently. Grease should not be allowed to accumulate in hood and filters.
- Always make sure cabinet and work surface are capable of supporting heavy cooking utensils used on your range.
- Always make sure cooking utensils are suitable for range top service. Only certain types of glass, glass ceramic earthenware/glazed utensils with stand sudden temperature changes without breaking.
- Always make sure your appliance is properly installed and grounded by a qualified technician.
- Always make sure your appliance is serviced by a qualified technician.



NEVER

- Never store items of interest to children above the range.
- Never allow children to climb on, sit or stand on any part of the range.
- Never allow children to play with the controls or any part of the range.
- Never wear loose fitting clothing or other flammable materials that could contact hot surfaces on the range.
- Never leave boiling pans unattended, boil over causes smoking and greasy spillovers may ignite.
- Never store gasoline or other volatile liquids in the range or in cabinets above or near the range, which can catch fire or explode.
- Never use water on grease fires. Smother fire or flame or use a dry chemical or foam type extinguisher.
- Never repair or replace any part of the appliance unless recommended in this manual. All other servicing should be carried out by a qualified technician.

- Never cover or restrict the air flow to the controls compartment.
- Never install cabinets (shelves) or similar above the range with a depth greater than 13" (330mm).
- Never heat unopened food containers. Pressure build-up may cause the container to burst and cause injury.
- Never reach directly into a hot oven to add or remove cooking utensils. Instead pull the grid shelf out to its maximum projection.
- Never use a steam cleaner to clean your range.
- Never use a power spray or oven cleaners on the control panel.
- Never use caustic cleaners, abrasive pads or metal scrapers to clean enamel surfaces.
- Never use aluminium foil as a protective liner on the oven base, except as suggested in the manual. Improper use of this type of liner may create a risk of fire.

Deep Fat Frying

- Use a deep pan.
- Never fill the pan more than one-third full of fat or oil
- Never use a lid on the pan.
- **Important:** Oil is a fire risk, do not leave pans containing oil unattended.
- In the event of a fire, cover the pan with a lid and turn OFF the appliance.
- Do not try to fry too much food at a time, especially frozen food. This only lowers the oven temperature of the oil or fat too much, resulting in greasy food.
- Always dry food thoroughly before frying, and lower it slowly into the hot oil or fat. Frozen foods in particular, will cause frothing or spitting, if added too quickly.
- Never heat fat, or fry with a lid on the pan.
- Keep the outside of the pan, clean and free from streaks of oil or fat.

Smother the flames on the hob preferably with a fire blanket, rather than attempting to remove the pan to the outside.

Burns and injuries are caused almost invariably by picking up the burning pan to carry it outside.

Do not hang dish towels on the left hand side of the AGA handrail. Doing so will block the air vent. Blocking the air vent can cause excessive temperature increase to the control panel and prevents easy access to the controls.

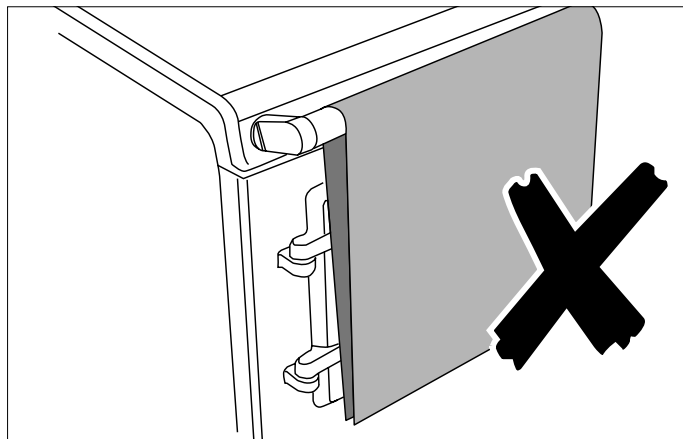

When the oven(s) are on **DO NOT** leave any oven door open for long periods, this will effect the temperature of the oven and may allow controls to become hot.

A little smoke and some odor may be emitted when the appliance is first switched on. This is normal and harmless (from oven lagging and starch binder on the element insulation) and will cease after a short period of use.

CAUTION: The Control System of your AGA will, because of regulatory compliance requirements, implement a software reset at 2.00 am local time. The reset process will turn off the external vent fan. If you have at any time manually set the vent fan to be ON, please check its operation before you commence cooking.

3. Introduction

As responsible manufacturers we take care to make sure that our products are designed and constructed to meet the required safety standards when properly installed and used.

Your new AGA eR7 gives you everything you love about the classic AGA heat storage cooker, but with the added convenience of touchscreen technology and the ability to turn each cooking area on and off, as and when you want it.

Made in the heart of Shropshire, England, your AGA cooker, like the generations of cookers before it, has been manufactured from cast iron. Traditional iron-making skills combined with industrial strength elements enable the ovens and hotplates to heat up rapidly, so you can have them all on, or just one.

The cooking excellence of the AGA range has been famous since its inception in the 1920's and is renowned due to the indirect radiant heat that its cast iron emits rather than just air temperature. And, if you haven't found out already, you'll soon discover that food that is cooked this way retains its natural flavour and succulence, and simply just tastes better.

So grab a cup of tea, have a read, and prepare to dig into some of the tastiest dishes you're ever likely to make.

 **IMPORTANT NOTICE: PLEASE READ THE ACCOMPANYING WARRANTY.**

Any alteration that is not approved by AGA could invalidate the approval of the appliance, operation of the warranty and could affect your statutory rights.

In the interests of safety and effective use, please read the following before using your new AGA appliance.

The use of the cooking appliance results in the production of heat and moisture in the room in which it is installed. Ensure that the kitchen is well ventilated: keep natural ventilation holes open or install a mechanical ventilation device (mechanical extractor hood).

Prolonged intensive use of the appliance may call for additional ventilation, for example, opening of a window, or more effective ventilation, for example increasing the level of mechanical ventilation where present.

Installation must be to local and national wiring regulations and carried out by a qualified engineer.

A little smoke and some odour may be emitted when first switched on. This is normal and harmless (from oven lagging and starch binder on the element insulation) and will cease after a short period of use.

4. Overview

WARNING: ACCESSIBLE PARTS MAY BECOME HOT DURING USE. TO AVOID BURNS AND SCALDS CHILDREN SHOULD BE KEPT AWAY.

AGA eR7

Fig. 4.1

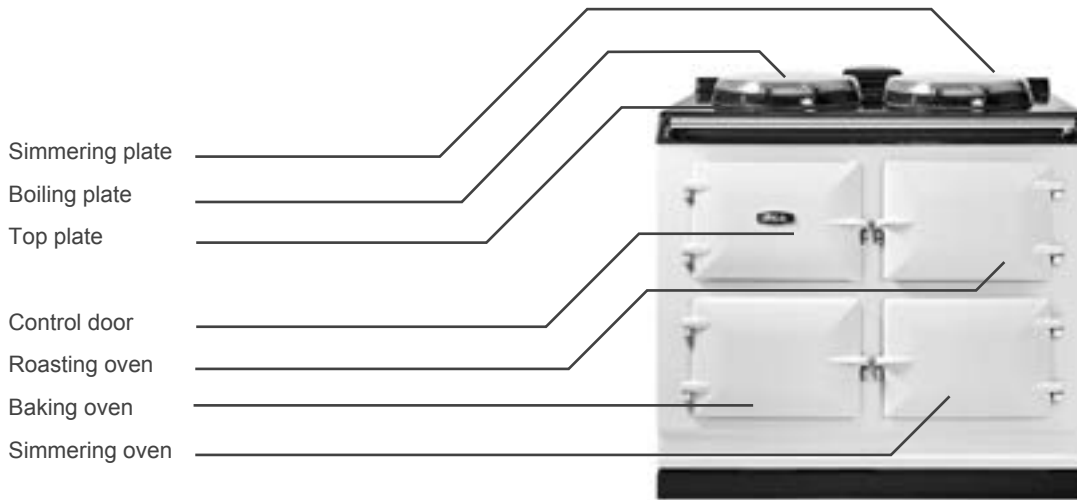

Hotplates

The two hotplates are at different heats; the boiling plate being the hottest of the two and the simmering plate is a lower heat. Each plate is individually controlled.

Boiling Plate

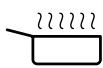
 The boiling plate is used for making toast, boiling a kettle, stir-frying and cooking at a higher heat.

Simmering Plate

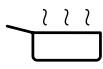
 The simmering plate is for slower cooking, such as sauces, simmering pans and can also be used to cook on directly for toasted sandwiches, drop scones, no-fat fried eggs and quesadillas.

Roasting Oven

 The hottest oven for high temperature cooking; pastries breads, roasting of meat, vegetables and poultry, grilling at the top of the oven and frying on the floor.

Baking Oven

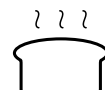
 A moderate oven for cooking cakes and biscuits, baking fish, lasagne or shepherds pie, plus roasting meat and poultry at a medium heat. Cooking sweet and savoury together is no problem as the flavours do not mix.

Simmering Oven

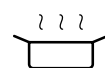
 Long, slow cooking in the Slow Cook Oven develops flavours and makes the toughest meat tender. It's large capacity means several pans can be stacked here; soup, casserole, steamed rice, steamed carrots and poached pears all cooking simultaneously, without any danger of burning.

WARNING: ACCESSIBLE PARTS MAY BECOME HOT DURING USE. TO AVOID BURNS AND SCALDS CHILDREN SHOULD BE KEPT AWAY.

AGA eR7 with Hotcupboard

Fig. 4.2



Hotplates

The two hotplates are at different heats; the boiling plate being the hottest of the two and the simmering plate at a lower heat. Each hotplate is individually temperature controlled.

 **Boiling Plate**

The boiling plate is used for making toast, boiling a kettle, stir-frying and cooking at a high heat.

 **Simmering Plate**

The simmering plate is for cooking slower, such as sauces, simmering pans and can also be used direct on for toasted sandwiches, drop scones, non-fat fried eggs and quesadillas. (Use of Bako-Glide will protect the hotplate surface during 'direct on' cooking)

Warming Plate (Hotcupboard)

The warming plate is the ideal resting place for cooked food.

Slow Cooking Oven (Hotcupboard)

Ideal for a broad range of long slow cooking applications, such as leg of lamb, pulled pork, belly pork and celebration cake.

NOTE: Meat and vegetable dishes should be started on the boiling plate or in the roasting oven.

Warming Oven (Hotcupboard)

Used for warming plates and serving dishes. Can also be used for resting joints before carving.

 **Roasting Oven**

The hottest oven for high temperature cooking pastries, breads, roasting of meat, vegetables and poultry, grilling at the top of the oven and frying on the floor. The oven has 5 pre-set cook settings R9, R8, R7, R6 and B4 which gives the flexibility to vary the oven temperature from very hot to moderate. The oven, as the others, is vented into the room, so some cooking smells will be present.

 **Baking Oven**

A moderate oven for cooking cakes and biscuits, baking fish, lasagne or shepherd's pie, plus roasting meat and poultry at a medium heat. The oven has 4 pre-set cook settings B4, B3, B2 and B1 which gives the flexibility to vary the oven temperature from moderate to cool. Cooking sweets and savoury together is no problem as the flavours do not mix.

 **Simmering Oven**

Long, slow cooking in the simmering oven develops flavours and makes the toughest meat tender. Its large capacity means several pans can be stacked here; soup, casserole, steamed rice, steamed carrots and poached pears all cooking simultaneously, without any danger of burning. The oven has a fixed temperature.

5. How to use your AGA eR7

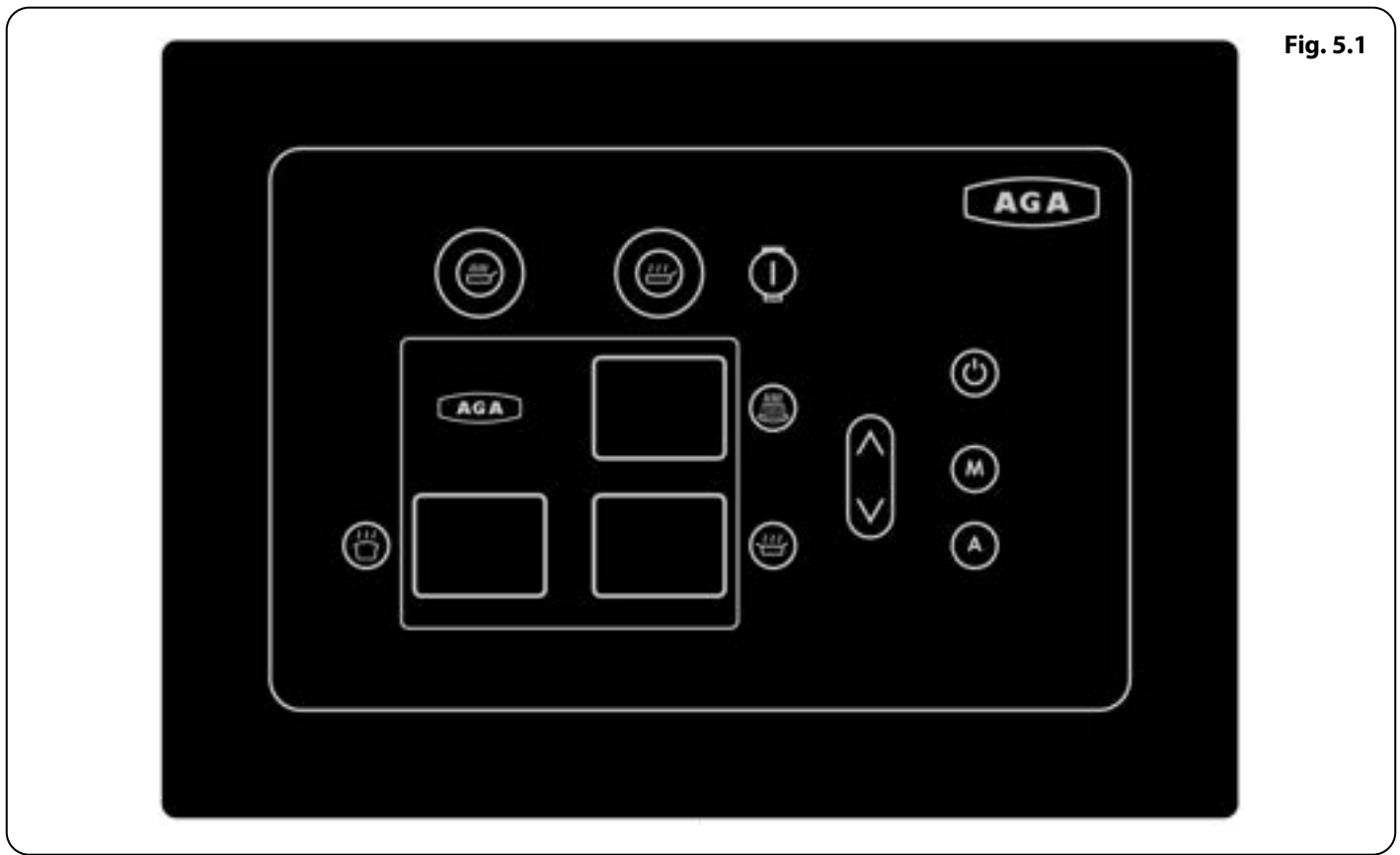

Fig. 5.1

Control Panel Fig. 5.1

This is situated behind the top left hand door. The control panel has a capacitive touch screen with LED indicators and character display to indicate which zone is activated and what setting is selected.

Handset Fig. 5.2

Your AGA eR7 cooker also comes with a Handset which can be used to program the ovens. It displays the time, date and program events. The hotplates work on Manual only.



Fig. 5.2

DESN 517465

Getting started

When switching on the AGA cooker for the first few times, there are two things you may notice, neither of which should cause concern.

1. The AGA cooker will emit an odour for a short while, this is simply due to the protective oil we put on the hotplates and ovens burning off. Due to the newness in the first couple of hours, it is advisable to open the kitchen window while this takes place.
2. Condensation may occur on the top and front plate whilst the AGA cooker is heating up, caused by the insulation lagging and starch binder on the element insulation drying out. The condensation should be wiped away as soon as possible to prevent staining the enamel.



Your AGA eR7 has the external appearance of a classic AGA heat storage enamelled cast iron cooker. However its flexibility is almost unbounded because in place of a single heat source each cooking zone has its own electrically heated cast iron element(s). The separation of cooking zones, allows a choice of control. You are able to select only those zones that you want, or need, to use.

The control panel is situated behind the top left hand door and has a capacitive touch screen with LED indicators and character display to indicate which zone is activated and what setting is selected. An audible beep will confirm selection.

To turn on the cast iron hotplates press on/off button  to turn on the power to the appliance. The 'Power ON/OFF' button and 'Manual Select' button will light up.

Operating the hobs

Press the Hob power button  which illuminates to indicate the hotplate and simmer buttons are ready to be activated. If the hotplate or simmer plate is not selected within 3 seconds the 'Hob Power' button will deactivate.

With the 'Hob Power' button active the hotplate and/or simmer plate can be turned on by pressing the centre of the symbol  . The symbol outer ring will blink until the desired temperature is reached, at which point the LED will become solid.

Options to turn the hobs Off

De-select the hotplate or simmer plate by pressing the illuminated symbol. The LED will turn off to indicate that hob is no longer active. After 3 seconds of both hotplate and simmer plate being de-selected the 'Hob Power' LED will automatically deactivate.

Both the hotplate and simmer plate can be turned off together by pressing the 'Hob Power' button .

To turn OFF all zones press on/off button (Ovens & Hob) .

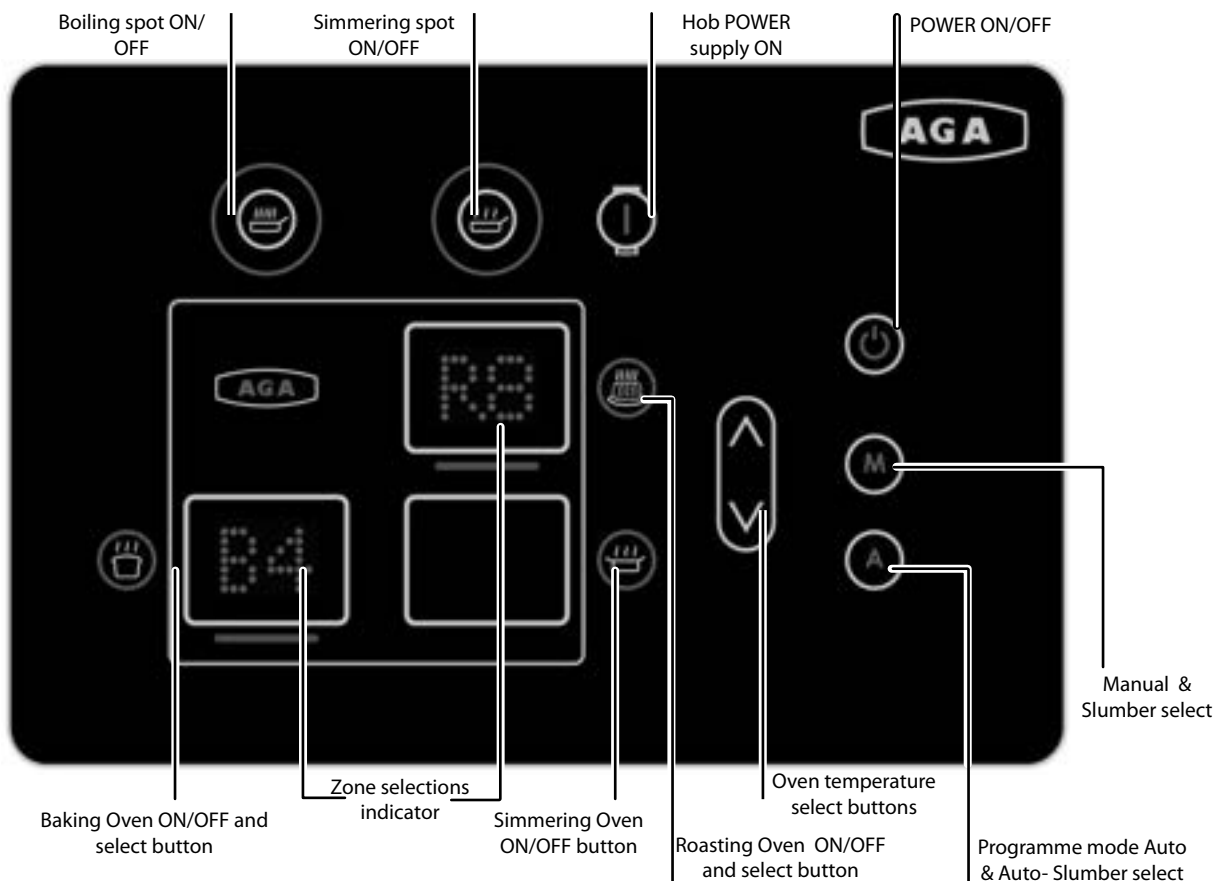

Operating the Ovens

The appliance has 4 oven operating modes:

- MANUAL
- SLUMBER
- AUTO
- AUTO-SLUMBER



Selection can only be made when the on/off button is on.

Manual mode *(ovens only)*

In this mode, all three ovens can be activated and the desired cooking temperature selected.



Press on/off button  to switch on the power to the appliance.

The 'M' button  will be illuminated to indicate the appliance is in manual mode.

Each oven can be selected by pressing the appropriate button.   

The selected oven will blink until the desired temperature is reached. For the roast and bake ovens the oven setting will also be displayed in the relevant window (Roast oven – 'R8' and Bake oven – 'B4').

To change the oven setting, press the desired button, a red selection bar will appear under the relevant window to indicate the setting can be changed.

Use the UP  or DOWN  arrows to change the setting. The red selection bar will remain active for 30 seconds.

To turn OFF a single oven press the desired button.



For the roast and bake ovens, the button is to be pressed twice, once to select and once to switch OFF.



To turn OFF all zones press on/off button (Ovens & Hob) .

Slumber setting *(ovens only)*

In this mode, all three ovens are active, (the roasting and baking oven are pre-set to approximately 248°F, the simmering oven is pre-set to approximately 212°F).

Press on/off button  to switch on the power to the appliance.

Press and hold the 'M' button  for 3 seconds, which will blink to indicate slumber mode is selected.

The 3 oven symbols will illuminate    and blink until at the desired temperature. The settings display window for the roast and bake ovens will display the letter "S" to indicate slumber mode.

To cancel Slumber, press and hold the 'M' button  for 3 seconds or press on/off button  to turn OFF all zones (Ovens & Hob).

To override an oven setting while in slumber mode

No individual oven can be 'OFF'. However the roast or bake oven can be switched from 'Slumber' to a cooking setting. This is achieved by pressing the relevant symbol once. A selection bar will appear under the relevant oven and the default setting is displayed. (Roast oven – 'R8' and Bake oven – 'B4') The desired setting can then be selected by using the arrow buttons as previously described.

Pressing an individual oven button once more returns that oven back to 'Slumber'

If both roast and bake ovens are overridden the appliance will revert back to manual mode and the 'M' button  will become solid to indicate it is no longer in slumber mode.

Auto

This mode setting brings selected ovens up to full heat from off.

The ovens can be selected to operate once or twice each day.



Each operation is termed an 'event', the start and finish time is chosen by you unless you use the pre-set time.

Press on/off button  to switch on the power to the appliance.

Press 'A' button , which illuminates to indicate the cooker is in Auto mode.



Select oven (s) for automatic operation, by pressing the appropriate button (s).   

Select the desired cook setting by using the arrow symbols. Press the desired button, a red selection bar will appear under the relevant window to indicate the setting can be changed.

Use the UP  or DOWN  arrows to change the setting. The red selection bar will remain active for 30 seconds.

The roast and bake ovens will indicate selection by displaying the setting and the letter 'A' in the display window. After 30 seconds only the letter 'A' will be displayed until the event time is reached. During an event period the desired setting will be displayed in the window and the relevant oven symbol will blink until the desired temperature is reached.

When the simmering oven is selected the symbol will blink to indicate selection and will continue to blink until an event period as started and the temperature reached.

To cancel AUTO mode press 'M' button  to return to manual mode or press on/off button  to turn OFF all zones (Ovens & Hob).

AUTO/Slumber (ovens only)

This mode setting brings selected ovens up to full heat from Slumber.



The ovens can be selected to operate once or twice each day.

Each operation is termed an 'event', the start and finish time is chosen by you unless you use the pre-set time.

Press on/off button  to switch on the power to the appliance.

Press 'A'  then press and hold the 'A' button for 3 seconds.

Select ovens for automatic slumber operation, by pressing the appropriate buttons.   

The 3 oven symbols will illuminate    and blink until at the desired temp (slumber).

The 'A' button  will blink continually while in Auto slumber mode.

Select the desired cook setting by using the arrow symbols. Press the desired button, a red selection bar will appear under the relevant window to indicate the setting can be changed.

Use the UP  or DOWN  arrows to change the setting. The red selection bar will remain active for 30 seconds.

The roast and bake ovens will indicate selection by displaying the setting and the letters 'AS' in the display window. After 30 seconds only the letter 'AS' will be displayed until the event time is reached. During an event period the desired setting will be displayed in the window and the relevant oven symbol will blink until the desired temperature is reached.

NOTE:



During Auto-Slumber mode the simmering oven is not affected by event periods and can be switched ON or OFF at any time.

PLEASE NOTE:-

- Don't forget to include time for warm-up.
- Don't forget if you have set the AUTO/Slumber programme and have selected the AUTO/Slumber mode, an oven or ovens must be selected.
- The hotplates can only be operated manually.
- All the selected ovens will remain at 'Slumber' between 'events'.
- The last 'AUTO/Slumber' oven selection is remembered and re-called when 'AUTO' is next selected.
- **DO NOT OPERATE WITH THE APPLIANCE DOORS OPEN.**

AUTO and AUTO/Slumber

Changing between any of the four operating modes, will cause the hotplates to switch OFF if in use - this is a built-in safety factor. They can be switched back on after the mode change if required.

To cancel AUTO/SLUMBER mode press 'M' button  to return to manual mode or press on/off button  to turn OFF all zones (Ovens & Hob).

6. Cooking on your AGA eR7

The AGA eR7 is designed to give you flexibility when cooking a range of dishes through the four settings in the baking oven and the five settings in the roasting oven, as well as the long slow cooking in the simmering oven.

When referencing recipes from cookbooks, the eR7 pre-set cook settings are equivalent to the gas mark number.

The guide below gives an indication of the settings to use for specific foods, but the degree of cooking is often down to personal taste and you will soon find the settings which suit you. Happy cooking!

eR7 Pre-set oven settings	Description	Equivalent cooking Temperature °F	Equivalent Fan Oven Temperature °F	Typical Food Type
Simmering / Slumber	Very low	230-248	194-212	Very slow drying of meringues Slow cooking of stews, casseroles, meats, vegetables and poaching fruit. Food must be brought to temperature before placing in the simmering oven with the exception of meringues.
B1	Cool	284	248	Slow braised meat eg salt beef. Very rich fruit cake, pavlova.
B2	Slow	302	266	Slow roast eg. pork belly, ribs, gammon, lamb. Simnel cake, finishing lemon meringue, rice pudding, shortbread, cherry cake, custards eg crème caramel
B3	Moderately low	320	284	Curry, casseroles, stews, gammon, slow cooked meat, suet puddings eg steak and kidney, chilli. Cherry cake, Madeira cake, light fruit cake and cheesecake.
B4	Moderate	356	320	Tray bakes, sandwich cakes, small cakes, flapjacks, biscuits, bread and butter pudding, roulade
R6	Hot	392	356	Pastry, pizza, garlic bread, gratin, baked fish, baked chicken, toad in the hole, roasting meat, browning potato toppings on pies, moussaka, lasagne, baked vegetables eg dauphinoise potatoes, roasting nuts, finishing pasta bakes and soufflé. Fairy cakes, swiss roll, muffins, crumble.
R7	Hot	428	392	Bread, choux, roasting meat, soufflé, fish cakes, crackling, puff pastry pies and tarts, roasted vegetables and potatoes, baked potatoes, browning potato toppings on pies. Blind baking pastry, fruit pies, scones, quiche.
R8	Very hot	446	410	Roasted Mediterranean vegetables, potatoes. Fast roasting meat and poultry. Pizza and grilling
R9	Very hot	464	428	Fast grilling

7. General advice

Food **SHOULD NOT** be placed into any oven until it is up to normal operating heat i.e. the display for the chosen oven zone is solid and not flashing.

The oven doors should not be left open for long periods of time during cooking and heating up.

Warm up times

When a zone is heating up it will be indicated by a blinking red light on the control panel. When a zone has reached temperature a solid red light will indicate it has warmed up. AGA recommends that to fully saturate the castings it is best to leave them for one hour for the optimum cooking results.

Boiling Plate

The boiling plate takes approximately 11 minutes to reach temperature from cold.

Simmering Plate

The simmering plate takes approximately 8 minutes to reach temperature from cold.

Roasting Oven

The roasting oven takes approximately 35 minutes to reach R8 from cold, and approximately 15 minutes to reach temperature from 'Slumber'.

Baking Oven

The baking oven takes approximately 22 minutes to reach B4 from cold, and approximately 15 minutes to reach temperature from 'Slumber'.

Simmering Oven

The simmering oven takes approximately 45 minutes to reach temperature from cold.

PLEASE NOTE: For optimum cooking performance, after the temperature has been reached, we recommend leaving for another 30 minutes for the castings to become heat saturated, particularly relevant if you are cooking a large meal or baking.

PLEASE NOTE: The times are based on each zone being operated individually. If a large combination of zones are turned on simultaneously, it may slow down the individual warm up times. If all zones are turned on at the same time it will take approximately one hour for the whole appliance to reach operating temperature.

These times are based on the cooker having a single phase supply of 32 amps @ 230 V. For other power supply configurations, these times may change.

8. Handset – A hand held control

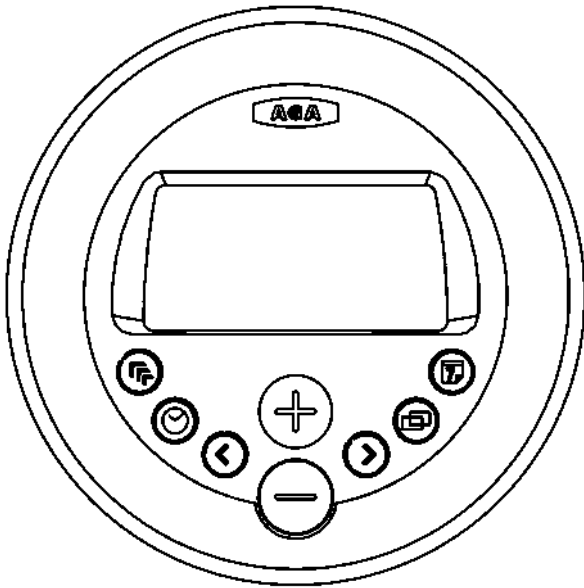

The handset displays the time, date and events. Programming uses eight push buttons. The information is displayed using a back-lit LCD screen.

Screens

The handset has 3 main screens.

The display will revert to 'sleep' mode after approximately 3 minutes. Simply press the required button to open up any screen.

1. Information Home screen (main menu)
2. Date/Time screen
3. Events Programming screen

Button operations

1.  **Communication or 'Handshake' button** used initially to synchronise the handset to the AGA eR7.
2.  **Clock button** Opens and closes the date and time settings screen.
3.  **Left/Back Button** Moves back and highlights the previous setting.
4.  **Plus Button** Increases the highlighted setting.
5.  **Minus Button** Decreases the highlighted setting.
6.  **Right/Forward Button** Moves forward and highlights the next setting.
7.  **Copy Button** Copies the time programme from the current day to the following day in the 7-day event calendar screen.
8.  **7-day event Button** Opens and closes the 7-day event calendar screen.

9. Handset advice

Operating distance



The handset will only operate in the same room as the cooker and up to a maximum distance of 4 metres from the appliance. If out of recommended operating range, the handset may show 'Standby'. If this happens move the handset back to within the recommended distance and it should correct itself, see below.

Handset to AGA eR7 Signal Check

The  (Standby) symbol is shown when in the following situations;

1. Standby mode
2. Communications fail
3. A power cut
4. Handset is out of range of the AGA eR7 cooker

When transferring information from or to the controller always operate the handset in front of the cooker, this gives the strongest signal.





If the handset shows  Standby, when the cooker is on, press the  button firmly for 1 second, this will activate the communication link between the cooker and handset.

Communication/Handshake

For details on initial Communication/Handshake, see **"Communication/handshake" page 16.**

Preview Mode

If the handset is out of range of the cooker or if the appliance is switched off, Preview only mode is available. Changes cannot be made to the programmed events. The  symbol is displayed in the screen and the message 'Preview only' is displayed briefly when the events programme screen is first entered.

When in Preview Mode you can review the days by using the  and  buttons. The  and  buttons become inactive and you cannot make any changes.

Handset Failure

In the unlikely event of handset failure, the appliance would still be operational with the last selected programme. The cooker can also be changed to Manual mode from one of the auto modes using the mode button on the control panel. If the handset is damaged or lost, a replacement can be obtained from AGA and re-programmed to suit your appliance.

DO NOT PLACE THE HANDSET ON ANY HOT SURFACES.

10. Communication/handshake

This process will be required on the original installation of the AGA eR7. If the handset is replaced for any reason the new handset will need to be synchronised.

- You will also need to set the time and date.
- You will also be given the option to set your own Auto programme preferences.

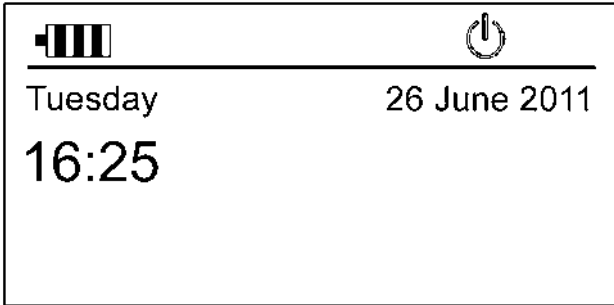

Step 1



Handshake can be activated 30 seconds after mains power has been applied to the cooker. The Standby button on the touch panel must be 'ON'. It must then be completed within 2 minutes, otherwise you will need to repeat the process.

Step 2

Press and hold  button on the handset for 10 seconds to open the communicate/synchronise screen. The following screen message then appears.

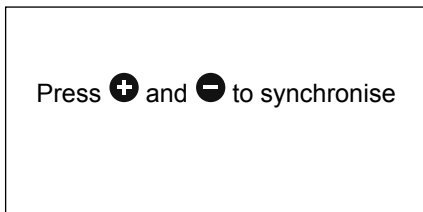
Step 3



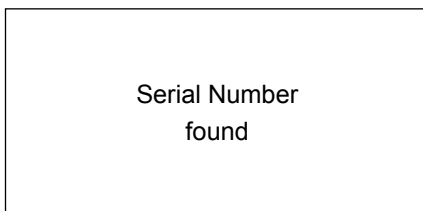

Simultaneously press the  and  buttons, the serial number will be 'found' by the handset.

The following screen message then appears briefly.



Step 4

Use the  and  buttons to choose the language you want the handset text to be in, then press  to confirm the language choice required.

Once time and date has been set the Auto/Event programme screen will appear.



Step 5

Set the correct time and date see "**The date/time setting screen**" page 17.

Step 6

You have the option to set your own Auto programme at this stage, see "**The date/time setting screen**" page 17. If you wish to leave until later, then press  it will remain at the pre-set times: 1 Event 7am - 7pm (7 days).

Notes



-  Symbol appears in the top right hand corner of the screen, if the handset is out of range with the cooker or the communication/handshake process has not been completed. When communication is OK then  symbol is displayed.
- The  button can be used to force communication between the cooker and the handset. This function is active once successful initial communication has been made, and the handset is in range.

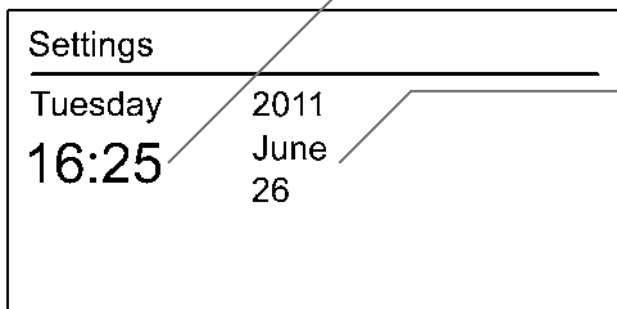

11. The date/time setting screen

Press and hold Clock button  until the screen is displayed.

In this screen the time, date, month and year can be altered/set.



Press the  or  buttons to alter the highlighted time, date, month and year settings.

Press the  or  buttons to cycle between the time, date, month and year.

Press  button at any stage to save the settings and exit the DATE/TIME screen.

'Message sent OK' will appear on the screen when the handset is in range of the cooker.

'Changes stored on handset only' will appear on the screen, when the controller handset is out of range of the cooker.

Notes

- Even if no changes are made to the time, date, month and year settings, a press of the clock button  is still required, to return to the Home screen.
- The day cannot be changed as the handset automatically knows this information, when the date and year is set.
- The Home screen will automatically appear after the replacement of new batteries.

12. Auto/events programme screen

This screen is opened by pressing the 7-day event button .

In this screen, the number of events and the start and end time of events can be set. Each day can have a different number of events, and start and end times, or all seven days can be the same.

There are pre-set times already programmed, to change to your desired settings follow these instructions. Pre-set times are 1 event 7am - 7pm (7 days).

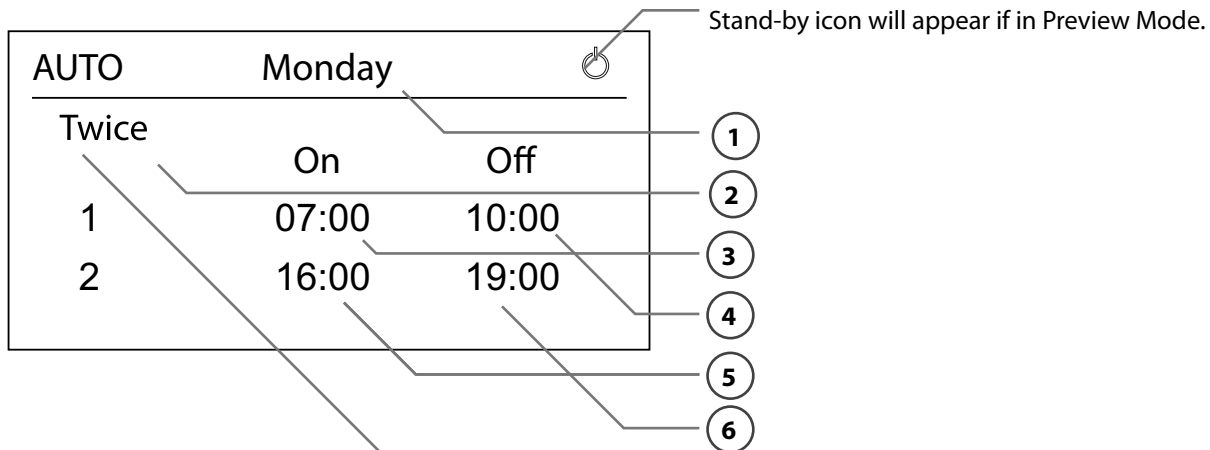













Stand-by icon will appear if in Preview Mode.

'Twice' will be shown if two events are set.





'Once' will be shown if one event is set.

'No' will be shown if no events are set.

What you can do



1. The current day is shown on the display, this can be changed to the day that you wish to edit by pressing the  and  buttons.
2. This shows the number of events in that day. This can be changed from no, once or twice by pressing the  and  buttons.
3. This shows the start time of the first event. This can be changed by pressing the  and  buttons.
4. This shows the end time of the first event. This can be changed by pressing the  and  buttons.
5. This shows the start time of the second event. This can be changed by pressing the  and  buttons.
6. This shows the end time of the second event. This can be changed by pressing the  and  buttons.

How you do it

Press the  or  buttons to navigate through the settings on the screen. When a setting is selected it will be highlighted by a dark box. Pressing the  and  buttons. will change the information in this highlighted box.

Press  to copy program settings to next day.

If you have made changes and wish to exit this screen, press the  button. A 'Save Changes' - Yes or No? message will appear on the screen.

Pressing the  and  buttons will highlight Yes or No. Press the  button again to confirm your choice.

REMEMBER: After setting the Auto event that an oven selection must be chosen on the touch panel  if you wish to activate the programme you have just entered.

Notes

- Even if no changes are made a press of the  button is still required, to return to the Home screen.

13. Information (home) screen

This is the main screen, where information such as time, date, battery life and connectivity is displayed. If you have programmed either of the 'AUTO' modes and they are currently in progress, the next change of event will also be displayed. The information below explains this in more detail.

Press any button on the handset to open this screen, from 'Sleep' mode.

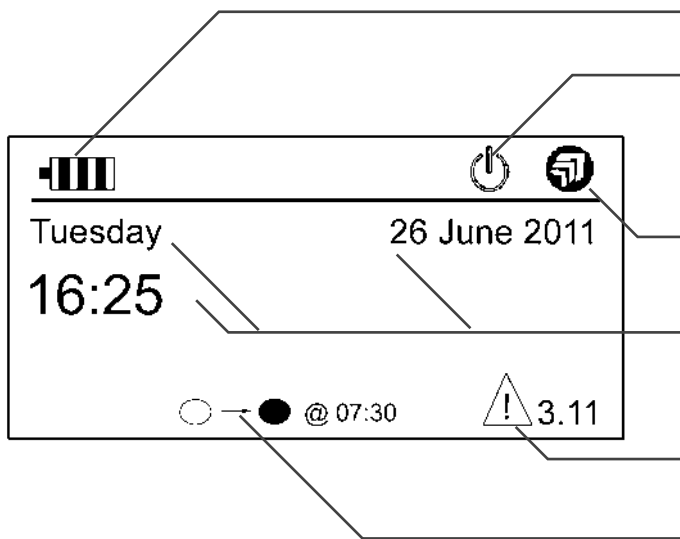

Change of event symbols

- → ● **AUTO event on**
(before AUTO event)
- → ○ **AUTO event OFF**
(during AUTO event)
- ⏻ → ● **AUTO/Slumber event ON**
(before AUTO/Slumber event)
- → ⏻ **AUTO/Slumber event OFF**
(during AUTO/Slumber event)

Symbol indicating the battery life.

If there is no communication between the AGA eR7 and the handset because: the cooker is not powered, in standby or the handset is out of range from the cooker. The ⏻ symbol is displayed.

Communication/Handshake symbol indicates communication between the cooker and handset is OK.

Symbols indicating the current time and day.

Warning triangle and error code is displayed if an error occurs.

If either AUTO or AUTO/Slumber mode is active the next event change will be displayed for that day with the relevant symbols to show start and end times.

NOTE: If standby icon is shown then event indicator will not be displayed.

Power cuts under 10 minutes

When the power is restored, the AGA eR7 will resume normal operation as was set prior to the power interruption.

Power cuts over 10 minutes

Most functions will have turned OFF.

- 'Manual' mode - all zones OFF.
- 'Slumber' mode - hotplates OFF, Slumber ON
- 'AUTO' mode - hotplates OFF, ovens continue with the set programme.
- 'AUTO/Slumber' - hotplates OFF, ovens continue with the set programme.

A 'Power Cut' message may appear on the handset screen, confirm by pressing any button on the handset. Therefore the cooker may not be at temperature when expected.

Automatic update of time

In the event of power cuts the handset will automatically update the controls within the cooker to the correct time on restoration of power. This is provided that the following criteria are met:

1. The handset is sited within range of the cooker
2. The handset has good batteries
3. The handset contains the correct time itself

PLEASE NOTE: The handset time will need to be updated with Spring and Autumn time changes B.S.T / G.M.T. See "**The date/time setting screen**" page 17.

14. Batteries

The handset is fitted with four 'AAA' batteries, which are packed separately. Your Engineer will insert them when your AGA eR7 cooker is installed. When replacing the batteries, follow these instructions in conjunction with the diagrams.

Remove the handset from its backplate, then remove the battery cover plate from the rear of the handset (**Fig. 14.1**).

Carefully lever out the batteries commencing with the bottom one first pushing and pulling out on the **positive (+) end only** (**Fig. 14.1**). Repeat this procedure to remove the other batteries.

Always use long life batteries for replacements - rechargeable batteries are not recommended.

Replace the batteries commencing with the bottom one working to the top (**Fig. 14.3**).

Battery life will depend on usage. Replace the batteries when the battery symbol on the handset is down to one bar.

Care and cleaning

The handset should be wiped clean using a soft clean cloth. **DO NOT** use abrasive cleaning products or submerge the handset in water.

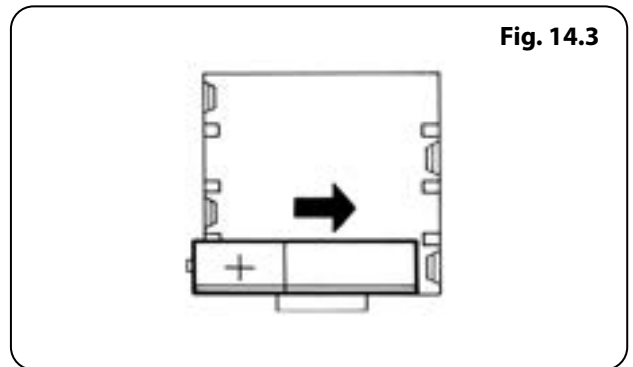
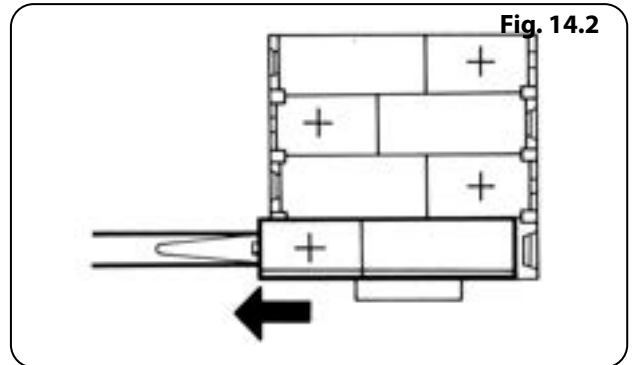
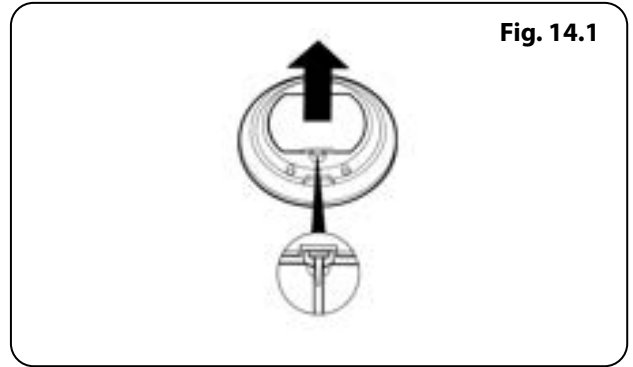

15. Equipment supplied with your AGA eR7

Getting to know you AGA eR7

If you have not already seen a demonstration, ask your AGA Specialist for details. A demonstration will show you how to get the best from your new AGA and will give you hints and tips. You will also see a selection of AGA utensils and accessories being used.



Large Size Roasting Tin with Grill Rack

This is designed to slide onto the oven runners without the need for it to sit on an oven grid shelf. The roasting tin can be used with the grill rack, in its high position, for grilling at the top of the roasting oven. It can be used for roasting meat, or poultry with or without the grill rack. Large quantities of roast potatoes can be cooked in this tin. The roasting tin can also be employed for making large traybakes or cakes. The grill rack is useful on its own as a cake cooling rack. Can be used in any oven but not recommended for hotplate use.

Half Size Roasting Tin and Grill Rack

This tin can be slid onto the oven runners width-ways or can sit on an oven grid shelf. The half size roasting tin can be used with the grill rack, in its high position, for grilling at the top of the roasting oven. It can be used for roasting smaller joints of meat, or poultry with or without the grill rack. Roast potatoes can be cooked in this tin. The roasting tin can also be employed for making traybakes or cakes. The grill rack is useful on its own as a cake cooling rack. It can be used in any oven but not recommended for hotplate use.



1 Floor Grid

This grid is used on the floor of the ovens, in particular the roasting and simmering ovens to protect food needing over 30 minutes cooking from the intensity of the heat from the base element.

3 Oven Grid Shelves

These are for inserting in each oven to provide a surface for dishes and tins which do not fit direct onto the oven runners. They can be used in any oven, as required. **“Fitting and Removing the oven shelves” page 15** on how to locate the oven shelves correctly.

Roasting Oven Perforated Baffle

A roasting oven perforated baffle is positioned in the top of the roasting oven, in order to optimise cooking performance. For best results, please ensure it is in place at all times, while the oven is in operation, including when grilling. The Installation Engineer will fit this in place. This can also be removed for cleaning.



Toaster

This is for toasting bread on the boiling plate. AGA toast is renowned for its excellence, crisp on the outside and soft in the centre. Take thick slices of bread and place in the AGA toaster - if the bread is very moist or very fresh, heat the toaster beforehand to prevent sticking - lift the boiling plate insulated cover and place the toaster direct onto the plate with the handle at an angle from the handle of the cover.

Close the cover and wait for the bread to toast one side - this will take 1-2 minutes dependent upon the variety of bread - open the cover and turn the toaster over and repeat the process to toast the other side. The toaster can also be used for heating pitta bread, toasting teacakes and as a cake cooling rack.



Wire Brush

This is for cleaning the raw cast iron hotplate surfaces, keeping them clear of crumbs and burnt on debris - which would otherwise affect the boiling performance of pans and the kettle. Use on the hotplates and the ovens. Take care not to touch the enamel surfaces as the wire brush will scratch the finish.



AGA Utensils and Accessories

To get the very best performance from your cooker we recommend AGA saucepans with the thick tri-core bases and stacking lids so that the maximum use of oven space is made and an AGA kettle for boiling water.

16. Fitting the Oven Shelves

Fig. 16.1

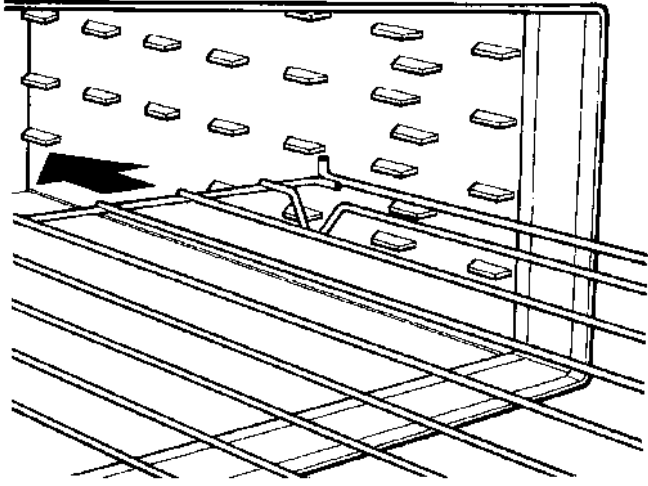

DESN 512403

Fig. 16.2

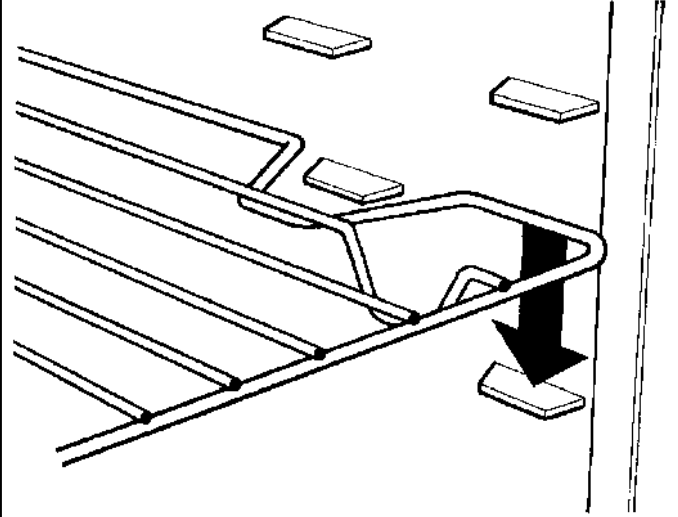

DESN 512404

17. Removing the Oven Shelves

Fig. 17.1

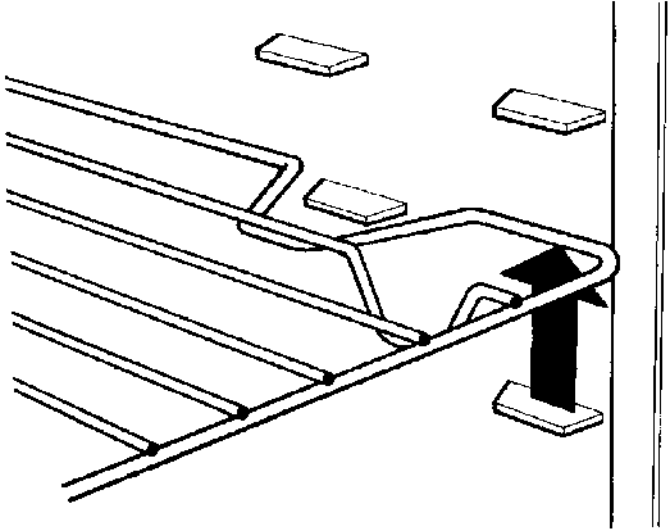

DESN 512405

Fig. 17.2

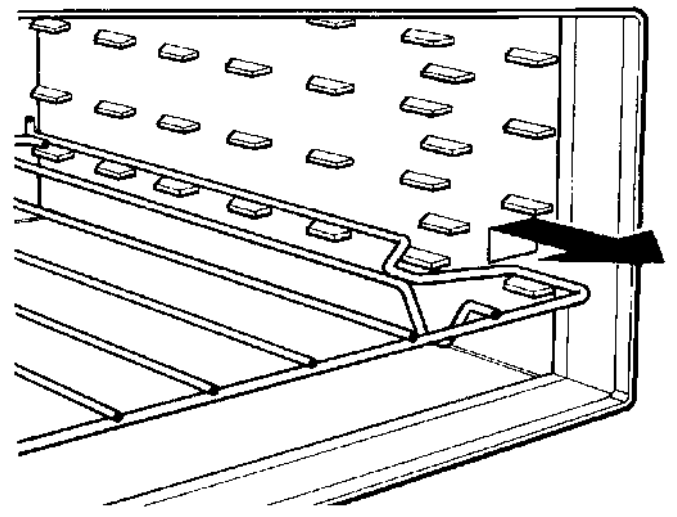

DESN 512406

18. Using the zones of the AGA eR7

The different zones of the AGA eR7 cooker are described in the following pages individually. Recipe suggestions are given for each area or zone with alternative cooking methods - the choice is yours whichever is most convenient to you. For instance you may prefer to use just the hotplates for a quick dinner in the week or there can be a choice of an oven alternative when you have the ovens on during the colder weather or at weekends, when you are doing more cooking.

The classic AGA heat storage cooker is famous for the gentle warmth it emits, with the AGA eR7 you will get warmth only when the cooker is on or warmth to a lesser degree when only parts of it are on.

The Plates

Hotplates

The hotplates are operated manually, make sure the standby button is on then just press the touch control panel of the hotplate you need and a flashing red light will appear, when the hotplate reaches its full preset heat it will become solid red.

The boiling plate is on the left hand side and the simmering plate is on the right hand side of the AGA eR7. The boiling plate is the hottest with the simmering plate being the cooler of the two. They both have electric elements embedded into the cast iron which heat up in approximately 11 and 8 minutes respectively. The hotplates can be used completely independently from the ovens.

This means the AGA eR7 differs from the classic AGA heat storage cooker in that they can be used for the entire cooking time of appropriate dishes because the design keeps the hotplates at a constant heat, whereas the classic AGA cooker continues to cook on a falling heat so for these we recommend starting on the hotplate(s) then transferring to the ovens, this can be done with the AGA eR7 but is not necessary. For instance, if making a pasta dish with sauce on the AGA eR7, it can all be done on the hotplates.

The whole hotplate area can be used for cooking and several pans can be accommodated on a single plate at any one time. The hotplates are set very slightly above the top plate to avoid accidental scratching if the pans are pulled to one side. **DO NOT** drag the utensils from one plate to another as the enamel will suffer!

The stainless steel insulated covers are brought down over the hotplates when they are not in use. When the hotplates are 'on' the insulated covers will be warm. We strongly advise not to put anything such as kettles, saucepans or baking tins directly onto the insulated covers because they will show any scratches - invest in a pair of chef's pads to protect the surface if the covers are to be used as resting places!

Keep the hotplates clear of any burnt on food or crumbs by brushing with the wire brush, supplied with your AGA. Cleaning details can be found on **page 35**.

Boiling Plate

The hottest hotplate, the boiling plate is used for boiling, frying, griddling, stir-frying, making toast - indeed anything that requires a high heat. Green vegetables keep their colour when boiled quickly here, or use a steamer over the saucepan to cook more than one vegetable at once.

When stir frying or cooking anything that is inclined to splash we would recommend using an AGA Splash Shield which will protect the insulated cover from splatter, making cleaning a doddle! Just wash the Splash Shield in hot soapy water or place in a dishwasher between two dinner plates.

Please be advised the boiling plate is too hot to cook food direct on it.

Simmering Plate

The simmering plate is the cooler of the two hotplates and so is used for recipes that require a lower heat such as, making sauces, scrambling eggs, heating milk, slow frying, simmering soups and root vegetables. In addition it can be used direct on as a form of griddle - invaluable for toasted sandwiches, quesadillas, drop scones, searing scallops and even a non-fat fried egg! Slow cooked toast can be made on the simmering plate, no need here to use the AGA toaster. Bako-glide can be used to protect the hotplate surface when direct on cooking.

Both boiling plate and simmering plate are the same size. Both are machined flat to give the best all over contact with the AGA saucepans, grill pan, frying and kettle.

Cleaning details can be found on **page 35**.

Top Plate

The top plate is the enamelled surface surrounding the hotplates. It will become warm when the AGA eR7 hotplates are in use. Although it is not a cooking surface you can use the warmth for a number of useful activities, which more often than not save times and washing-up! These include warming honey or syrup in the jar, or melting butter or chocolate in a basin - so saving on melting over a saucepan - but do please put the basin on a cork mat or folded piece of kitchen towel to avoid scratching the enamel. Although it is durable and hard-wearing surface vitreous enamel is glass and will show scratch marks!

The top plate when warm can also be used to rest a cup of coffee or tea or dry off awkwardly shaped tins, peelers or food mixer and processor parts.

The ovens

The roasting oven for high temperature cooking, offering a range of cook settings B4, R6, R7, R8, and R9.

The baking oven for moderate temperature cooking, offering a range of cook settings B1, B2, B3, and B4.

The simmering oven for long, slow cooking which is fixed at simmering temperature.

DO NOT OPERATE THIS APPLIANCE WITH THE DOORS OPEN, SINCE THIS CAN CAUSE A LOCK-OUT.

Each oven has the same capacity, (able to fit a 13kg (28lb) turkey) and the classic AGA heat-storage cooker techniques can be used such as stacking of saucepans in the simmering oven. This enables the steaming of root vegetables, rice, steamed pudding, casserole, poaching fruit all in the same oven leaving the hotplates free.

You can have one, two or all three ovens on at their pre-set heat or the roasting and baking ovens can also be at 'Slumber' mode, (the simmering oven is always at the same heat).

The ovens are made from cast iron, which cooks by a radiant heat and this is the secret of the cooking excellence for which the AGA cooker is renowned. An indirect radiant heat does not dry food out, so it retains its natural moisture and flavour.

Slumber mode

In Slumber mode, all three ovens operate like a simmering oven.

The simmering oven is always in Slumber, whereas the roasting and baking oven can be set on Slumber mode for either cooking at a low heat, or to generate gentle warmth into the kitchen, or in readiness for turning up to their normal pre-set heat.

Cooking at Slumber in the roasting or baking ovens gives the best results for making large rich fruit cakes and meringues as they benefit from the gentle heat up of top and base elements to ensure thorough cooking. Other foods which benefit from cooking at Slumber in these ovens are steamed and Christmas Puddings and slow cooking large joints of meat - start the cooking process before placing the oven on Slumber.

The roasting oven



The roasting oven is indirectly heated by two elements, one in the base of the oven and the other in the roof. These elements heat the air and the cast iron within to provide cooking results consistent with the classic AGA heat-storage cooker, with the flexibility of being able to turn it to change the cooking temperature.

The roasting oven can be used for 'grilling' at the top and 'shallow frying' on the oven floor, see "**Cooking on your AGA eR7**" page 12.

When cooking on the floor of the roasting oven for long periods of time (more than 30 minutes), place the floor grid on the floor of the oven before putting the food into the oven, this lifts the food away from the base element to ensure best cooking results are achieved.

A note when cooking on the floor of the roasting oven.....

- Please leave 1 hour before cooking directly on the floor of the oven, this is to ensure maximum temperature stabilisation of the base element.
- You can cook directly on the floor of the roasting oven for short periods of time e.g. pizza, quiche, or foods that take 30 minutes or less.

NOTE: The roasting oven perforated baffle should be positioned in the top of the roasting oven in order to optimise cooking performance. It must be in place at all times, while the cooker is in operation, including when grilling. (See diagram for fitment of roasting oven perforated baffle).

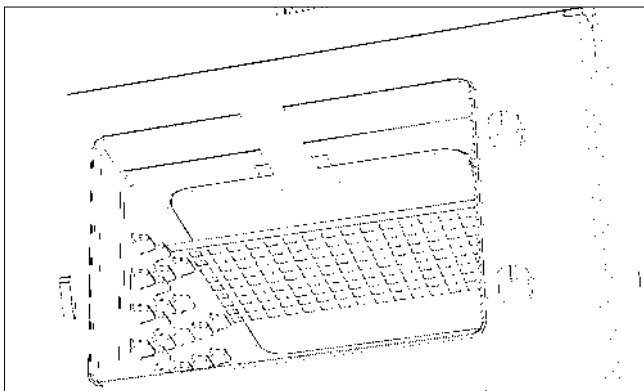

The roasting oven is zoned in heat, meaning it is slightly hotter towards the top than the centre and the oven grid shelf set on the oven floor is slightly less hot than the centre.

The floor of the oven can be used as another cooking surface, indeed it is often called a hidden hotplate - for food needing longer than 30 minutes, such as roast potatoes, on the floor of the oven you will need to use the floor grid for protection, so they do not over brown.

The beauty of the roasting oven is that any fat splashes are burnt off when the oven is at full heat, just brush out occasionally to get rid of carbon deposits.

The roasting oven is excellent for bread and pastries. Quiches in ceramic or pies in Pyrex dishes need not be baked blind as when they are placed on the floor of the oven the pastry cooks from underneath and the filling will set and brown from the all-round heat. As you are aware metal flan tins conduct heat quicker than ceramic so always place them on the floor grid placed on the floor of the oven to avoid over-base browning.

The specially designed roasting tins and bakeware slide directly onto the runners, so almost every available square centimetre of space can be used.

Roasting oven at slumber

When the roasting oven is set at Slumber it can be used to cook rich fruit cakes or slow cook roasts, casseroles and curries. With the exception of meringues and rich fruit cakes, food that is to be slow cooked should be brought up to heat before placing in an oven at Slumber. The light will flash when heating up to Slumber, then go solid when up to temperature.

The baking oven



The baking oven is indirectly heated by two elements, one in the base of the oven and the other in the roof. These elements heat the air and the cast iron within to provide cooking results consistent with classic AGA heat-storage cookers, with the flexibility of being able to turn it to change the cooking temperature.

This oven is set at a moderate heat, so is ideal for cakes, biscuits; also anything that requires medium heat cooking such as fish pie, lasagne, soufflés, crumble and roulades. Meat and poultry can be cooked here indeed most things that can be cooked in the roasting oven can be cooked in the baking oven but for a longer time, see **“Cooking on your AGA eR7” page 12.**

For the best results when cooking cakes do allow an hour heat up time. Cook cakes together on one shelf if two shelves are used interchange the food to achieve even colouration, as you would with any oven which is zoned in heat.

As with the roasting oven the specially designed roasting tins and bakeware slide directly onto the runners, so almost every available square centimetre of space can be used.

Baking Oven at Slumber

When the baking oven is set at Slumber it can be used to cook rich fruit cakes or slow cook roasts, casseroles and curries.

With the exception of meringues and rich fruit cakes, food that is to be slow cooked should be brought up to heat before placing in an oven at Slumber. The light will flash when heating up to Slumber, then go solid when up to temperature.

The simmering oven



The simmering oven is indirectly heated by one element in the base of the oven.

This element heats the air and the cast iron within to provide cooking results consistent with the traditional simmering oven of the classic AGA heat-storage cooker, with the flexibility of being able to turn it to Off when not required. The simmering oven is always at a simmer or Slumber mode ideal for long slow cooking.

The floor grid is used here to protect items placed on the floor of the oven such as vegetables for steaming, keeping sauces warm or casseroles cooked for a long time. Always ensure this is in place, before putting food into the oven.

The simmering oven can be described as a continuation oven, it continues to cook food that has been brought up to heat elsewhere on the cooker with the exception of meringues which are dried out rather than ‘cooked’.

The simmering oven



The simmering oven is indirectly heated by one element in the base of the oven.

This element heats the air and the cast iron within to provide cooking results consistent with the traditional simmering oven of the classic AGA heat-storage cooker, with the flexibility of being able to turn it to Off when not required. The simmering oven is always at a simmer or Slumber mode ideal for long slow cooking.

The floor grid is used here to protect items placed on the floor of the oven such as vegetables for steaming, keeping sauces warm or casseroles cooked for a long time. Always ensure this is in place, before putting food into the oven.

The simmering oven can be described as a continuation oven, it continues to cook food that has been brought up to heat elsewhere on the cooker with the exception of meringues which are dried out rather than 'cooked'.

User Guidance

- Allow the oven to heat up fully, the longer the oven is on the better, since this helps reduce the amount of moisture created during simmering.
- To get the very best performance, we recommend to use AGA cookware with thick bases and stacking lids.
- **DO NOT** place dishes directly on to the oven base. Always place onto either a shelf or the floor grid.
- Joints of meat and poultry should be brought up to heat ideally in the Roasting oven for 30 - 45 minutes, before transferring to the Simmering oven.
- This method is unsuitable for stuffed meat and poultry.
- Make sure that pork and poultry reach an internal temperature of at least 167°F.
- Always bring soups, casseroles and liquids to the boil before putting in the simmering oven.
- Always thaw frozen food completely before cooking.
- Root vegetables will cook better if cut into small pieces.
- Adjust seasonings and thickenings at the end of the cooking time.

- Many dried pulses and beans for example, dried red kidney beans must be boiled for a minimum of 10 minutes, after soaking, and before inclusion in any dish.

PLEASE NOTE: DO NOT store anything in the simmering oven and **DO NOT** use large cookware such as the large baking tray and large meat tin until the oven has reached its operating temperature. Failure to do this may cause the safety function to lock in the OFF position. It is also advisable when using large cookware in the simmering oven to push it to the back of the oven.

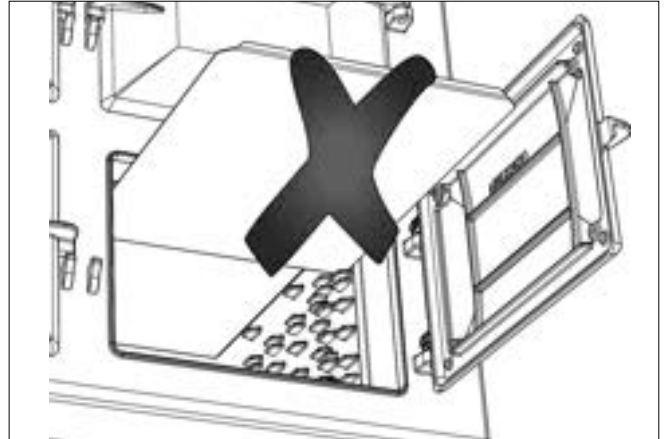

19. AGA (Hotcupboard)

Slow Cooking Oven plus Warming Oven

These ovens are heated by a single element at the rear of the oven cavity. It is operated by a single push ON-OFF button located on the left hand side of the hotcupboard top plate and can be turned ON and OFF when required. These ovens are not cast iron on the interior.

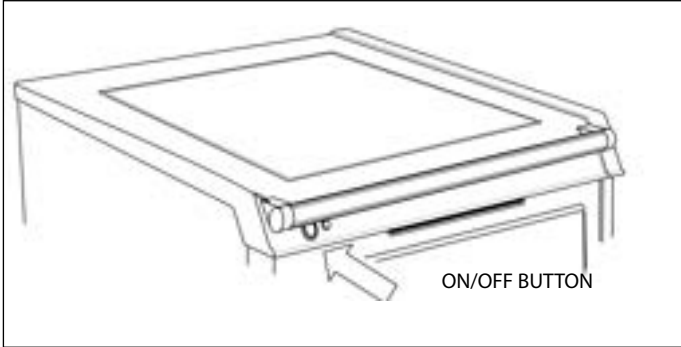

Slow Cooking Oven

This oven has similar characteristics of the simmering oven and should be utilised in a similar manner. It delivers a gentler convected heat making it better suited for longer cooking times especially for overnight cooking, for example rich fruit cakes and celebration cakes. The cooking of meringues may also be better suited for this oven.

NOTE: These ovens vent into the room, mechanical venting to the outside is not available.

Points to remember when Slow Cooking:

- Pre-heat the oven for 30 minutes before starting to cook.
- Bring casseroles, soups etc to the boil on the hob and start meat in the roasting oven, before placing in the slow cooking oven.
- Make sure that casseroles have sufficient liquid, particularly when cooking over a long period.
- Use lids on casseroles or foil to cover food whilst it is cooking to retain moisture.
- Make sure all dishes will fit into the oven before preparing food.
- Make sure that meat and poultry is piping hot before eating and reaches 167°F internal temperature.
- Always thaw frozen food completely before cooking.

You can also produce crisp, white meringues cooked in the slow cooking oven.

Timings for cooking in the slow cooking oven will depend upon the temperature, quantity and type of dish you are cooking, as a guide for casseroles, a minimum of 2 hours cooking time is recommended.

Keep an eye on the food until you are familiar with the oven.

The slow cooking oven can be described as a continuation oven. It continues to cook food that has been brought up to heat elsewhere on the cooker with the exception of meringues which are dried out rather than 'cooked'.

CAUTION:
This unit is heavy, proper equipment and adequate manpower must be used to remove the oven doors.

20. Fitting and removing the oven doors

Fitting the Doors

Fig. 20.1

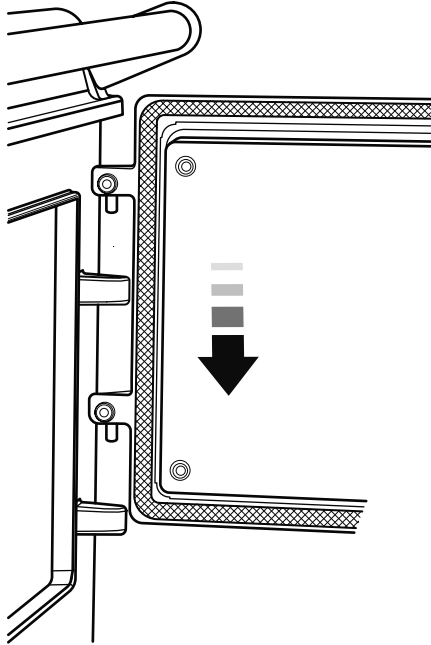

DESN 517491

Fig. 20.2

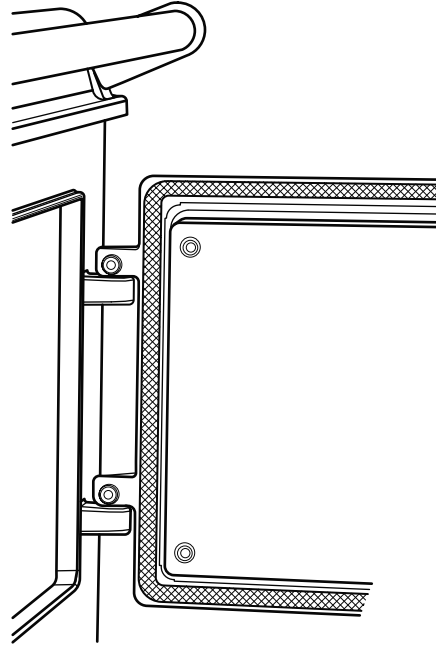

DESN 517489

Removing the Doors

Fig. 20.3

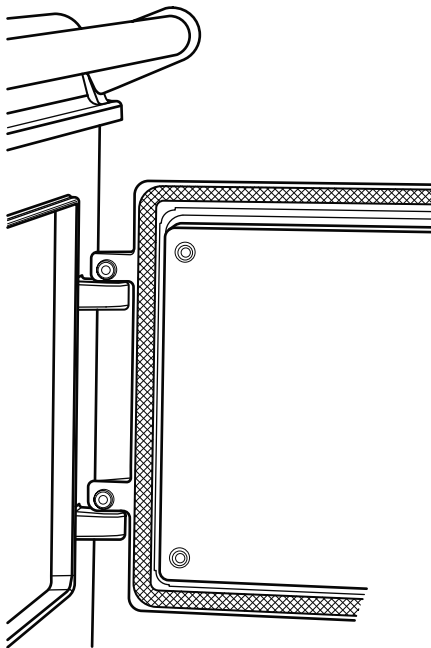

DESN 517489

Fig. 20.4

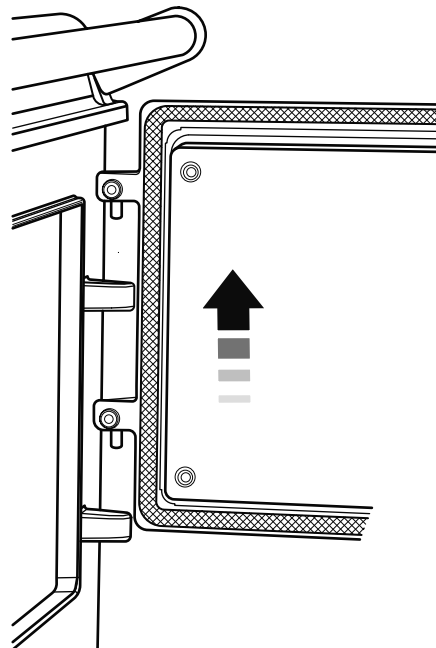

DESN 517490

21. Cleaning & Caring for your Range

WARNING: ACCESSIBLE PARTS MAY BECOME HOT DURING USE. TO AVOID BURNS AND SCALDS CHILDREN SHOULD BE KEPT AWAY.

- ⚠ **REMEMBER: be careful of the hot appliance.**
- ⚠ **For most cleaning it is best when the appliance is turned off.**
- ⚠ **DO NOT use a steam cleaner to clean this range.**
- ⚠ **DO NOT use abrasive pads, caustic cleaners, oven cleaners or metal scrapers to clean the surfaces of the enamel.**
- ⚠ **The touch control panel may be cleaned with a damp cloth and warm soapy water.**
- ⚠ **IMPORTANT: AGA recommend Vitreous Enamel Association approved cleaners for cleaning the vitreous enamelled surfaces of this product obtainable from your AGA Retailer.**
- ⚠ **When cleaning use as little water as possible.**
- ⚠ **DO NOT immerse the doors in water as they are packed with insulating material, which will be damaged by excessive moisture.**
- ⚠ **DO NOT put oven doors or resting plates in a dishwasher.**

Top Plate and Front Plate

- ⚠ **The easiest way to clean the AGA top plate and front plate is to mop up spills as they happen.**
- ⚠ **Baked on food is more difficult to clean but can usually be removed with proprietary vitreous enamel cleaners or mild cream cleaners using a cloth, or if necessary, a nylon scouring pad.**
- ⚠ **If milk or fruit juice, or anything containing acid is spilt on the enamel, wipe off immediately.**
- ⚠ **Clean off any condensation streaks on the front plate, around the oven doors or any vitreous enamel maybe permanently discoloured.**
- ⚠ **All that is usually needed to keep the vitreous enamelled surfaces of your range bright and clean is a daily rub over with a damp, soapy cloth followed immediately with a clean, dry cloth to avoid streaks.**
- ⚠ **Remember the top plate and the polished covers will scratch if pans or utensils are dragged across them.**

To keep the vitreous enamel surfaces of the range bright and clean, a daily rub over with a damp soapy cloth followed immediately with a clean, dry cloth to avoid streaks is all that is required. AGA E-cloths are excellent for this, obtainable from your AGA Retailer.

Cast iron ovens and hotplates

Ovens - are made from cast iron and keep themselves clean. They are very durable, but will rust if surface moisture is left on them. Remember to always switch the ovens on, to dry them out after cleaning.

Heating up the ovens periodically will help burn off any cooking deposits to aid cleaning within the ovens.

To season the ovens, a light vegetable spray oil (corn oil is best) is recommended. Any stubborn stains can be removed with the wire brush supplied.

Hotplates - is made from cast iron, and is easy to care for. Regular maintenance will ensure long-life. They will rust if surface moisture is left on them

Should the hotplates become soiled, use a sponge, cloth, scouring pad or wire brush to remove burnt-on spills.

Rinse off detergents or cleaning agents thoroughly.

Remember to switch on the hotplate for a few minutes to dry it after cleaning. Every now and then, apply a thin coating of vegetable oil (corn oil is best) when the hotplate is cold.

Lids and oven door/lids linings

The top of the insulated cover (lid) - this is chrome or stainless steel and can be kept clean by wiping over with a damp cloth and polished up - the AGA E-cloths are excellent for this purpose as they are lint-free and eco-friendly. AGA stainless steel and chrome cleaner are recommended to keep the insulated cover clean and shining. These can be purchased from your local AGA Specialist.

Lining of the insulated cover (lid interior) - the use of an AGA splash shield is recommended to keep the lining free of fat splashes, obtainable from your AGA Retailer.

If the lining is marked it is best cleaned when the hotplate is cold. It can be cleaned with hot soapy water and/or a cream cleanser. If badly marked then a soap impregnated pad can be used - this should be used in a circular motion.

The first few times a soap impregnated pad is used you will see the circular marks, these will become reduced and the surface of the lining becomes shinier each time when used. Do not use excessive water and make sure the lining is dry before closing the cover.

Oven door linings - the linings can be cleaned with hot soapy water, a cream cleanser or soap impregnated pad. To deep clean the lining place a towel on the work surface and carefully lift off the oven door (doors are heavy) and place it enamel side down on the towel padding. Clean with a soap impregnated pad to remove stubborn marks. Dry off before replacing on their hinges.

WARNING: ACCESSIBLE PARTS MAY BECOME HOT DURING USE. TO AVOID BURNS AND SCALDS CHILDREN SHOULD BE KEPT AWAY.

Roasting Pans

The enamelled roasting pans supplied with the AGA eR7 should be cleaned in hot soapy water, soaking if necessary. A nylon scouring pad can also be used. They may also be cleaned in the dishwasher, but with constant use, the enamelled finish will become dull in appearance.

DO NOT use caustic cleaners or oven cleaners.

PLEASE NOTE: Cleaners used for Vitreous Enamel are often unsuitable for use on: chrome and stainless steel components, including the insulating covers, hand-rails and their brackets.

22. Servicing and warranty

- Your Aga does not need to be regularly serviced.
- Fans may need periodic replacement.
- In the event of requiring maintenance, please call AGA Service or your authorised distributor.
- Your appliance **MUST** only be maintained and installed by a qualified engineer, AGA engineer or an authorised distributor.
- **DO NOT** alter or modify the appliance.

The appliance warranty does not cover Commercial use (see separate Warranty book provided for further details).

Error codes

In the unlikely event an error occurs with your AGA eR7 cooker, error codes may be displayed on your handset, for example:

3.11

Please provide AGA Service with this information. It will assist the service engineer with diagnosing your fault.

23. Installation Instructions

CAUTION: THIS UNIT IS HEAVY, PROPER EQUIPMENT AND ADEQUATE MANPOWER MUST BE USED IN MOVING THE RANGE TO AVOID DAMAGE TO THE UNIT OR THE FLOOR.

REMEMBER, when replacing a part on this appliance, use only spare parts that you can be assured conform to the safety and performance specification that we require.

DO NOT use reconditioned or copy parts that have not been clearly authorised by AGA.

**PLEASE READ THESE INSTRUCTIONS BEFORE USING THIS APPLIANCE
AND KEEP IN A SAFE PLACE FOR FUTURE REFERENCE.**

24. Installation requirements

Consumer protection

As a responsible manufacturer, we take care to make sure that our products are designed and constructed to meet the required safety standards when properly installed and used.

WARNING - ELECTRIC SHOCK HAZARD

It is the customer's responsibility to contact a qualified electrical installer to make sure the electrical installation is adequate and in conformance with the regulations.

Take special care when cutting holes in walls or floor. Electrical wires may be behind the wall or floor covering and could cause an electrical shock if you touch them.

Locate any electrical circuits that could be affected by the installation of this product and disconnect power circuit.

WARNING: THIS APPLIANCE MUST BE EARTHED.

DO NOT use an extension lead with this appliance.

The appliance is designed for the voltage stated on the data plate.

Recommended but not mandatory to fit an individual Residual Current Device (RCD) to the cooker supply circuit.

Hand this Manual to the User for retention and instruct in the safe operation of the appliance.

Delivery requirements

- The AGA eR7 arrives on 1 pallet
- The AGA eR7 with Hotcupboard arrives on 2 pallets.

There must be access to the kitchen to manipulate a foot print of 39 $\frac{5}{16}$ " (1005mm) x 29 $\frac{1}{8}$ " (740mm). A wooden template (skate with castor wheels) of dimensions 39 $\frac{5}{16}$ " (1005mm) x 29 $\frac{1}{8}$ " (740mm) could be used to check if the AGA eR7 fully built appliance is able to fit through the property grounds and doors into its installation position in the kitchen. It must also be considered that the height of the appliance is 37 $\frac{5}{8}$ " (960mm) off pallet and 43 $\frac{3}{8}$ " (1100mm) on the pallet, so high level obstacles/restrictions must not be overlooked.

If this skate/template can be manipulated through the property grounds and doors into position, then the AGA can be installed as intended with no re-work.

25. Location

Refer to **Fig. 26.1**.

It is recommended that any soft material flooring is removed from where the AGA will be installed.

It is essential that the base or hearth on which both range and/or module stands should be level and capable of supporting the total weight of one or both units.

The front plinth cover is removable and must not be obstructed by flooring or tiles. If necessary the range must be raised by the thickness of the tiles to ensure the plinth can be removed.

Any adjacent walls that project above the height of the hob must be of heat resistant material.

The side wall above the hob shall be greater than 3" (75 mm) from the range.

Surfaces over the top of the range must not be closer than 30" (760 mm).

The vent slots in the back of the top plate (or shroud) must not be obstructed.

NOTE: It is advisable that the supply cable is routed away from any hot surfaces i.e. hot water/flue pipes.

In the interest of safety, due consideration must be given to the protection of the electric cable to the range.

If a supply cord is damaged it must be replaced by the manufacturer, its service agent or similarly qualified persons in order to avoid a hazard.

The appliance is designed for the voltage stated on the rating plate, which is situated in the centre vent slot near the base of the front plate.

⚠ DO NOT install the range behind a decorative door in order to avoid overheating.

The complete range is floor-mounted and the space in which the appliance is to be fitted must have the following minimum dimensions:-

A minimum clearance of 2 ¼" (60 mm) is required above the raised insulating cover handle.

Overhead Cabinets

⚠ To eliminate the risk of burns or fires by reaching over hot surface units, cabinet storage space located above the surface units should be avoided.

Minimum Clearance to Combustibles

A gap of at least ½" must be observed between the rear of the top plate, and the wall behind the appliance. If the rear wall is of combustible material there must be a gap of 1" (25mm).

Range Hoods

It is recommended that this AGA is fitted with a range hood. The AGA venting system is located on top of the AGA between the two hotplates, and is designed for venting the moisture from the ovens. The cooker hood should be positioned not less than the minimum height as recommended by the manufacturer, from the top of the AGA.

Side Clearances

A ¼" (3 mm) gap is required each side between the range top plate and adjoining work surfaces that may be fitted, this is to allow for the safe removal of the top plate should this be required at a later date.

Where ranges are fitted against side walls a 4 ⅞" (116 mm) clearance is required on the right and left hand side for oven doors access.

If the AGA is to be installed in a brick recess, then the minimum clearance should be increased by at least ⅜" (10 mm), to allow for the walls not being square.

In addition, a minimum clearance of 39 ⅜" (1000 mm) must be available at the front of the range to enable the range to be serviced.

Tiling

When the range is to stand in a recess or against a wall which is to be tiled, in no circumstances should the tiles overlap the range top plate, access to remove the top plate must be allowed for servicing at a later date.

Rear Wall

A gap of at least ⅜" (10 mm) must be observed from the rear of the top plate, and the wall behind the appliance.

This appliance runs continuously, please take note of these **IMPORTANT** instructions:

Combustible Walls

Houses constructed of combustible materials (such as all-timber or stud wall partitions and batoned plasterboarded walls) require special wall heat protection features.

Non-combustible walls behind a range must be of at least 1" (25 mm) thick insulation board (Monolux or equivalent), up to hotplate level.

⚠ NOTE: Ensure electric cabling or plastic services do not pass within or on the outside of the wall, behind or directly above the range.

This type of material can age prematurely when exposed to continuous higher ambient temperature.

26. Clearances

Fig. 26.1

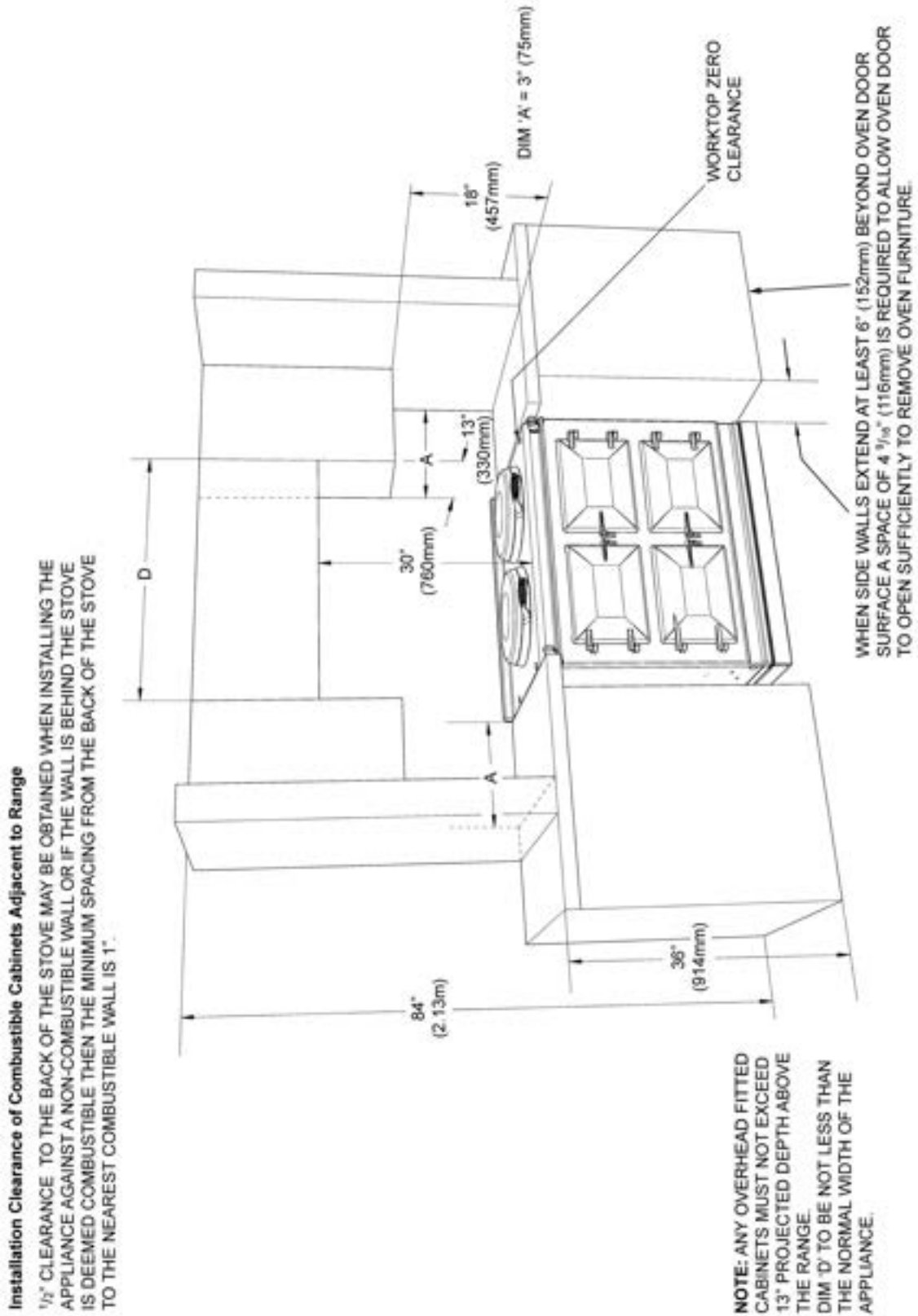

DESN 516298

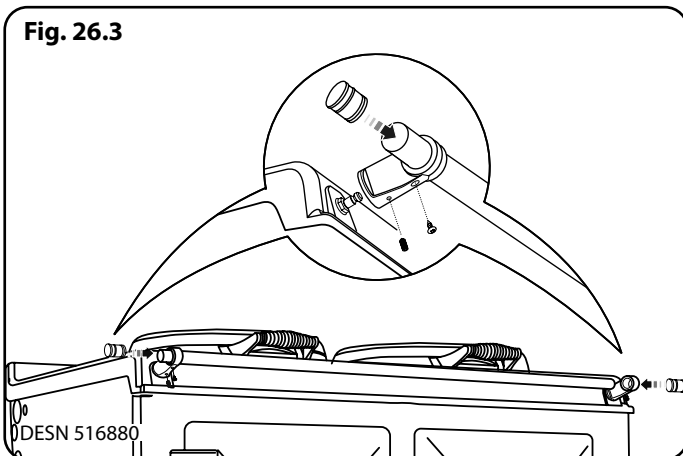
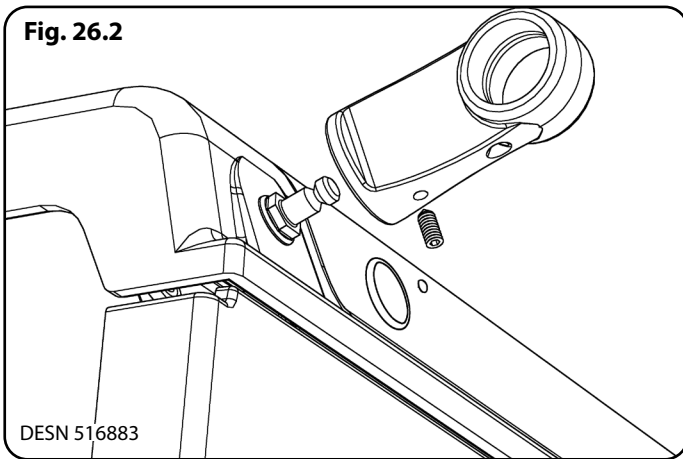

Fitting the Handrail

1. Fit the handrail bracket over the fixing stud located on the top plate. Lock into position by tightening the grub screw nearest the appliance **Fig. 26.2**.
2. Slide the handrail through the handrail brackets **Fig. 26.3**.
3. Once the handrail assembly is located squarely, lock the handrail in position by winding in the grub screws on the underside of each handrail bracket.
4. Once the handrails are locked in position, fit the handrail endcaps. The endcaps should be carefully pushed into place until they sit flush with the outside face of each bracket (a light smear of lubricant such as, hand or dish soap on the end cap 'O' rings may ease fitment **Fig. 26.3**).
5. Finally, fit the plinth fascia to the magnets on the front of the plinth. Make sure that the plinth fascia is centrally located and does not overhang the range.
6. Commission the AGA eR7, as stated in the relevant Installation Instructions and carry out functional test on each of the features of the AGA eR7.
7. Attach warning hanger (EGLL516660) located in literature pack, to AGA eR7 handrail when installation is complete. Advise customer to remove and read warning label.
8. Hand this Guide to the user for retention and instruct in the safe operation of the appliance.
9. Also advise the user that, for continued efficient and safe operation of the appliance, servicing is carried out at intervals recommended by the AGA distributor.

27. Appliance dimensions

AGA eR7 100-3

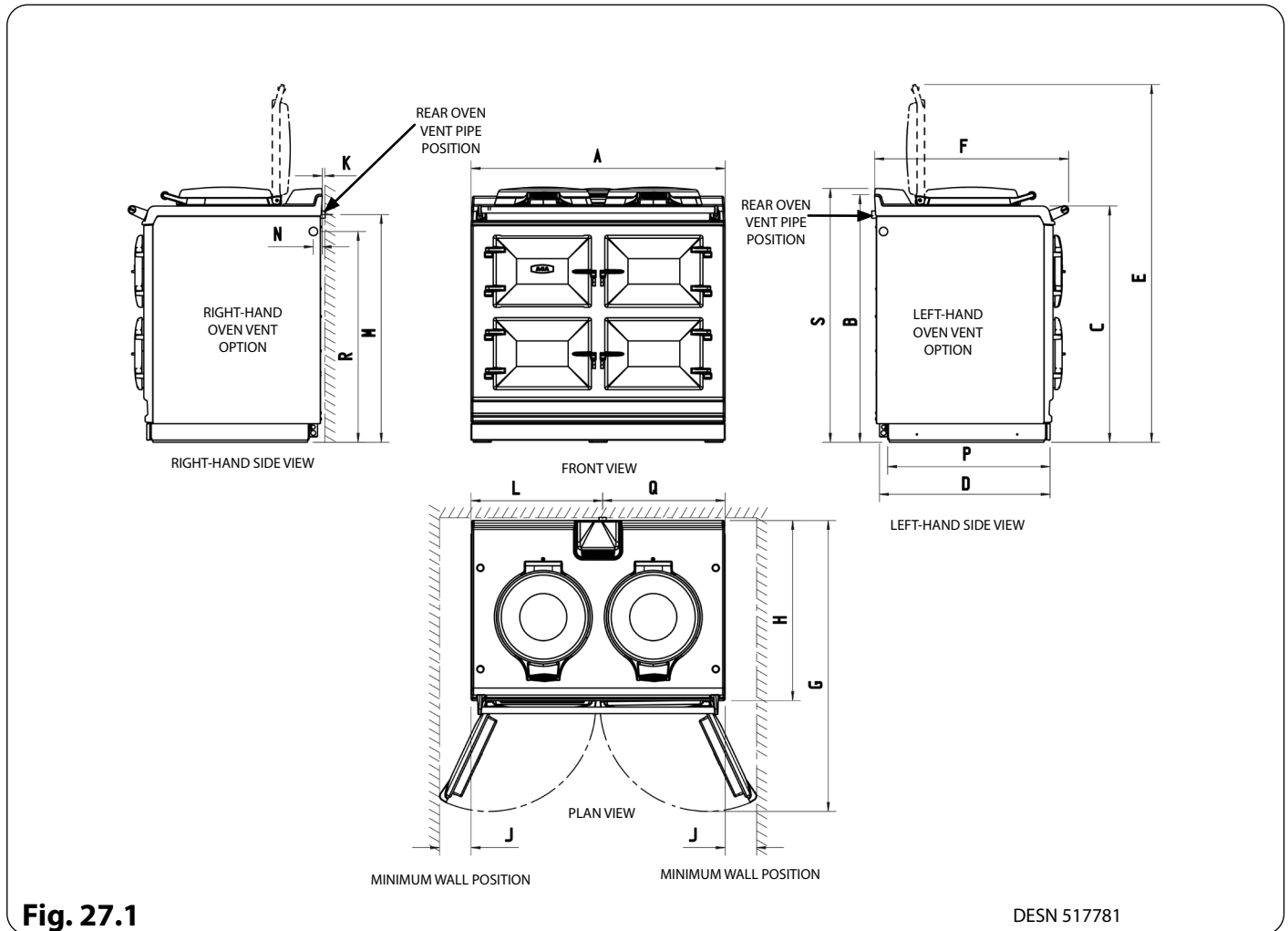

Fig. 27.1

DESN 517781

	A	B	C	D	E	F	G	H	J	K	L	M	N	P	Q	R	S
inch	38 7/8"	37 3/4"	36"	26 3/4"	54 5/8"	29 7/8"	45 1/16"	27 4/8"	4 7/8"	3/8"	20 1/15"	32 1/8"	1 3/8"	24 3/4"	18 1/16"	34 1/16"	38 3/4"

Cooker Dimensions

When surveying for a cooker installation the actual clearance required for the 'body' of the appliance should be increased by 3/8" beyond the figures quoted above. This allows safe margin to take into account the natural dimensional variations found in major castings. In particular the width across the appliance recess could be critical.

APPLIANCE WEIGHT

Model: AGA eR7 - 816 lb

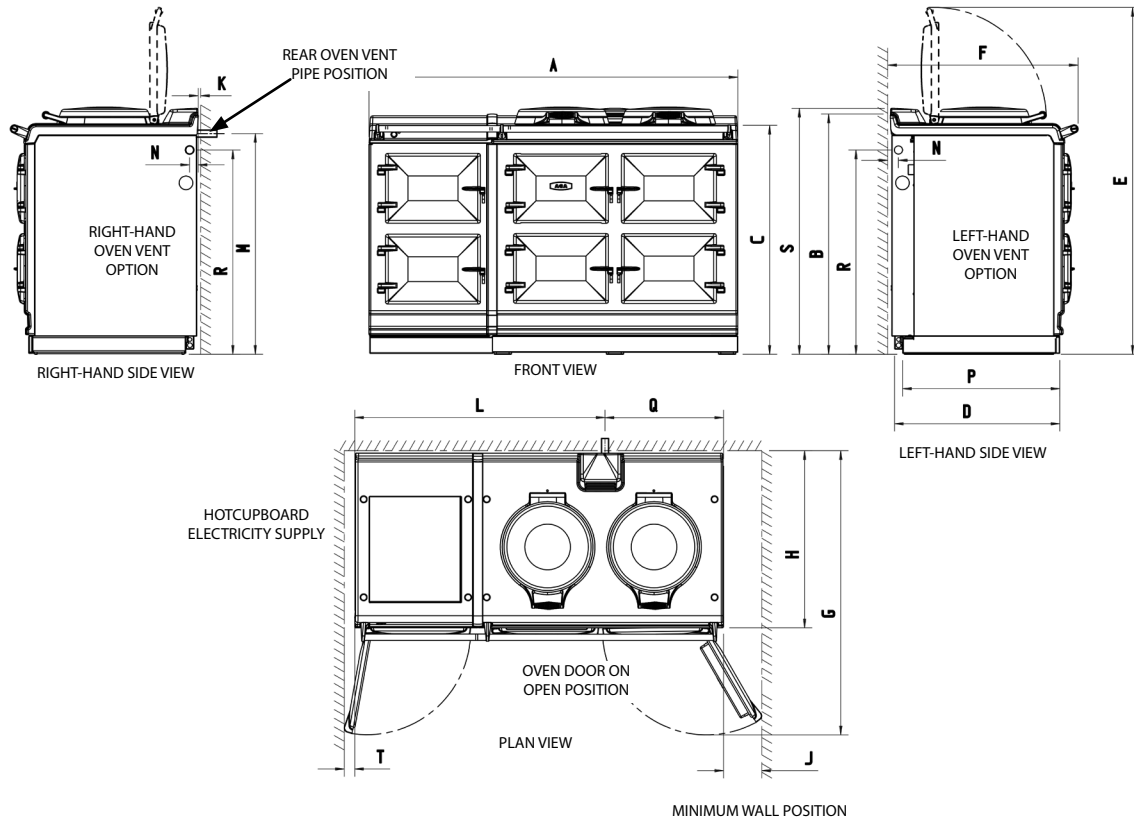

Fig. 27.2

DESN 517782

	A	B	C	D	E	F	G	H	J	K	L	M	N	P	Q	R	S	T
inch	58 3/16"	37 3/4"	36"	26 3/4"	54 5/8"	29 7/8"	45 1/16"	27 4/8"	4 7/8"	3/8"	39 7/16"	32 1/8"	1 3/8"	24 3/4"	18 11/16"	34 11/16"	38 3/4"	1 3/4"

Cooker Dimensions

When surveying for a cooker installation the actual clearance required for the 'body' of the appliance should be increased by 3/8" beyond the figures quoted above. This allows safe margin to take into account the natural dimensional variations found in major castings. In particular the width across the appliance recess could be critical.

APPLIANCE WEIGHT

Model: AGA eR7 - 816 lb

Hotcupboard - 243 lb

28. Connection to the Power Supply

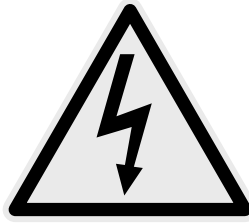

Electric Shock Hazard



The rating plate is located behind the removable plinth, see **Fig. 28.2**.

If the supply cord is damaged, it must be replaced by the manufacturer, its service agent or similarly qualified person to avoid a hazard.

Electrical Grounding is required on this appliance.

DO NOT connect to the electrical supply until the appliance is permanently grounded.

This appliance must be connected to a grounded, metallic, permanent supply. Or a grounding connector should be connected to the grounding terminal or wire lead on the appliance.

Failure to follow these instructions could result in death or serious injury.

This range must be supplied with a 240V, 60Hz power supply and connected to an individual, properly grounded branch circuit protected by a circuit breaker. At 240V, it has a maximum load of 30 amps. Electric hook-up must be done by a licensed electrician. This unit must be installed according to regional codes, or in the absence of codes, the National Electrical Code.

- Product installation requires a separate (not shared) 240V/40 amp circuit protected by an appropriate branch circuit supply.
- The service cord on your range is fitted with a standard four (4) prong type 14-50P plug (matching receptacle 14-50R).

The method of connection to the mains electricity supply must facilitate complete electrical isolation of the appliance.

The mains connection and isolation should not be positioned above the range and must be positioned within the area defined in **Fig. 28.2**.

THIS RANGE MUST BE COMPLETELY ISOLATED FROM THE ELECTRICITY SUPPLY BEFORE SERVICING. THE RANGE IS DESIGNED FOR THE VOLTAGE STATED ON THE RATING PLATE, WHICH IS SITUATED BEHIND THE PLINTH COVER.

⚠ WARNING: THIS APPLIANCE MUST BE EARTHED.

THIS APPLIANCE IS DESIGNED FOR THE VOLTAGE STATED ON THE RATING PLATE, WHICH IS SITUATED BEHIND THE PLINTH COVER.

IF THE SUPPLY CORD IS DAMAGED, IT MUST BE REPLACED BY THE MANUFACTURER, ITS SERVICE AGENT OR SIMILARLY QUALIFIED PERSON TO AVOID A HAZARD.

Mains Supply Location

Fig. 28.1

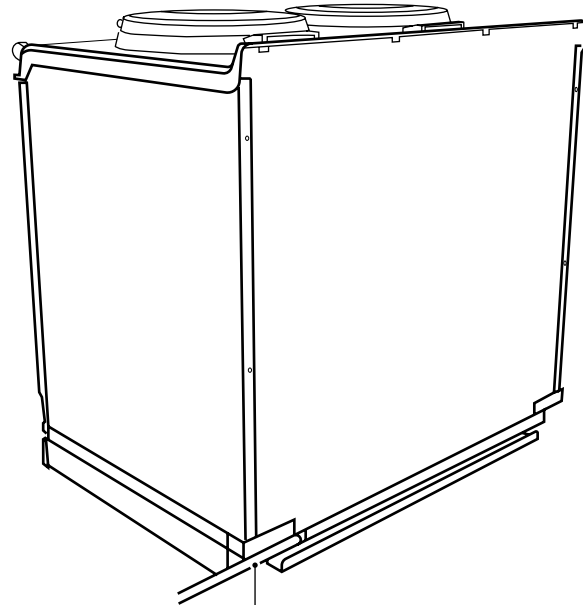

Mains cable fed from control tray
right-hand exit through ducting
dependent upon position of supply
socket

DESN 517444

Fig. 28.2

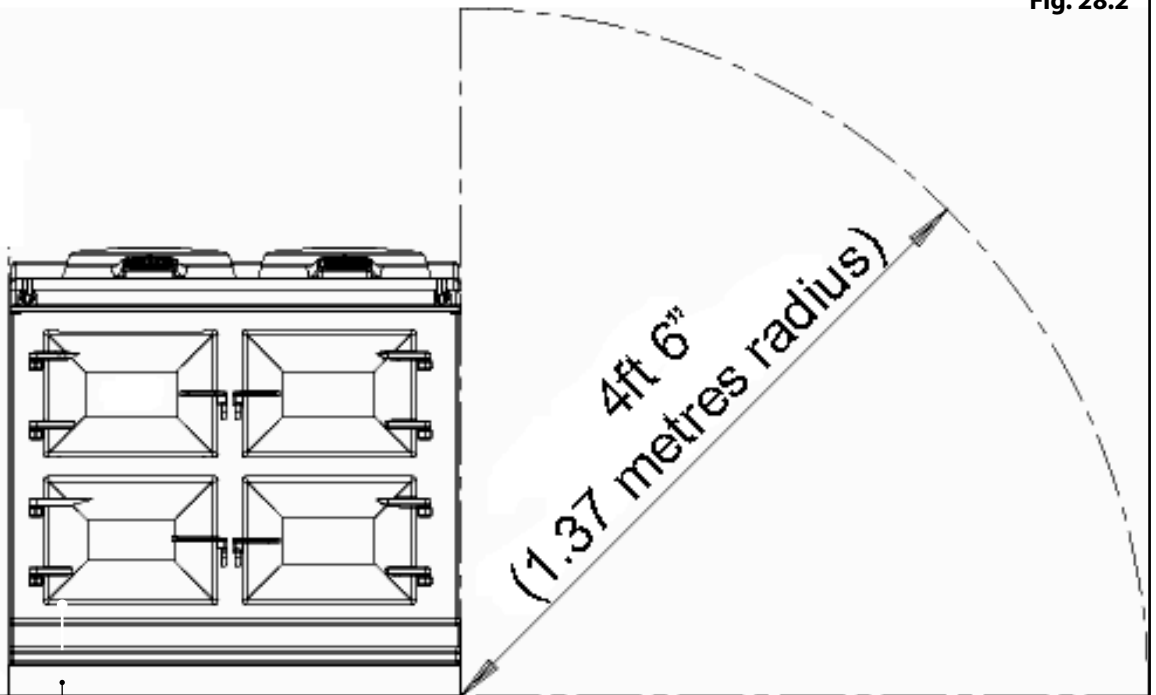

Data plate located behind toe-kick,
pull toe-kick to remove.

The mains supply connection and isolation point must be within the zone shown

DESN 516295

AGA Hotcupboard connections

THE HOTCUPBOARD ATTACHMENT REQUIRES A INDEPENDENT SINGLE PHASE POWER SUPPLY.

⚠ WARNING: THIS APPLIANCE MUST BE EARTHED.

THIS APPLIANCE IS DESIGNED FOR THE VOLTAGE STATED ON THE RATING PLATE, WHICH IS SITUATED ON A SLIDE-OUT TRAY IN THE HOTCUPBOARD BASE PLATE ABOVE THE PLINTH.

IF THE SUPPLY CORD IS DAMAGED, IT MUST BE REPLACED BY THE MANUFACTURER, ITS SERVICE AGENT OR SIMILARLY QUALIFIED PERSON TO AVOID A HAZARD.

A 120v ~ 60 Hz, 5 amp fused electrical supply is required adjacent to the appliance (with the exception of the AGA Hotcupboard with Induction Hob model, please refer to the AGA Induction Hob model instructions for the power supply requirements). External wiring to the unit must be installed using the mains cable provided, in accordance with the current wiring regulations and any local regulations which apply.

The method of connection to the mains electricity supply must facilitate complete electrical isolation of the appliance, preferably by a fused double pole switch, having a contact separation of at least $\frac{1}{8}$ " (3mm) in both poles.

The isolator should not be positioned immediately above the hotcupboard, but must be fitted with 6ft 6 $\frac{3}{4}$ " of the appliance.

Power supply - Hotcupboard with induction hob, please refer to owners manual supplied with the appliance.

29. Mains Supply Location

Mains cable routing

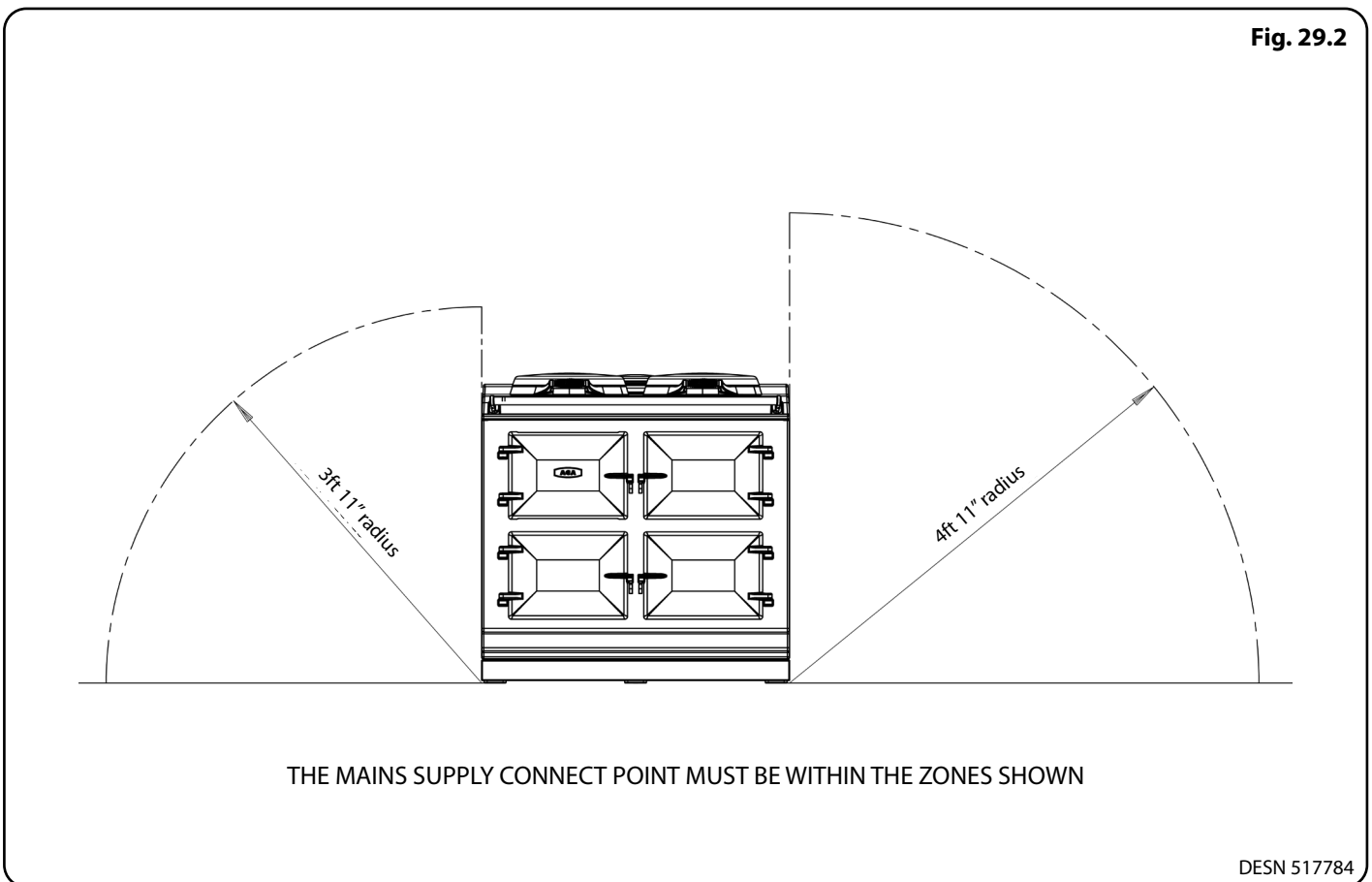
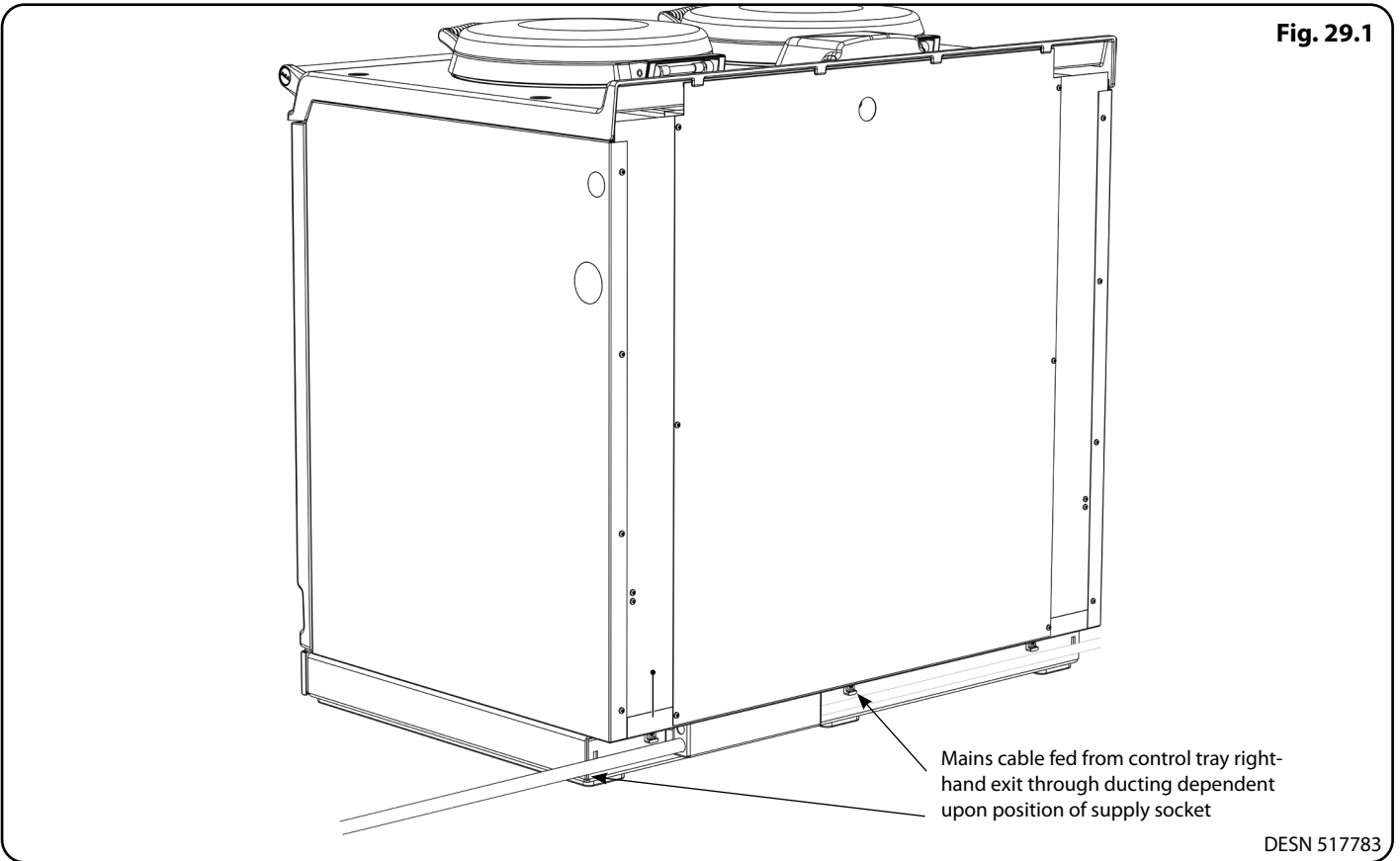

Mains cable routing- AGA Hotcupboard

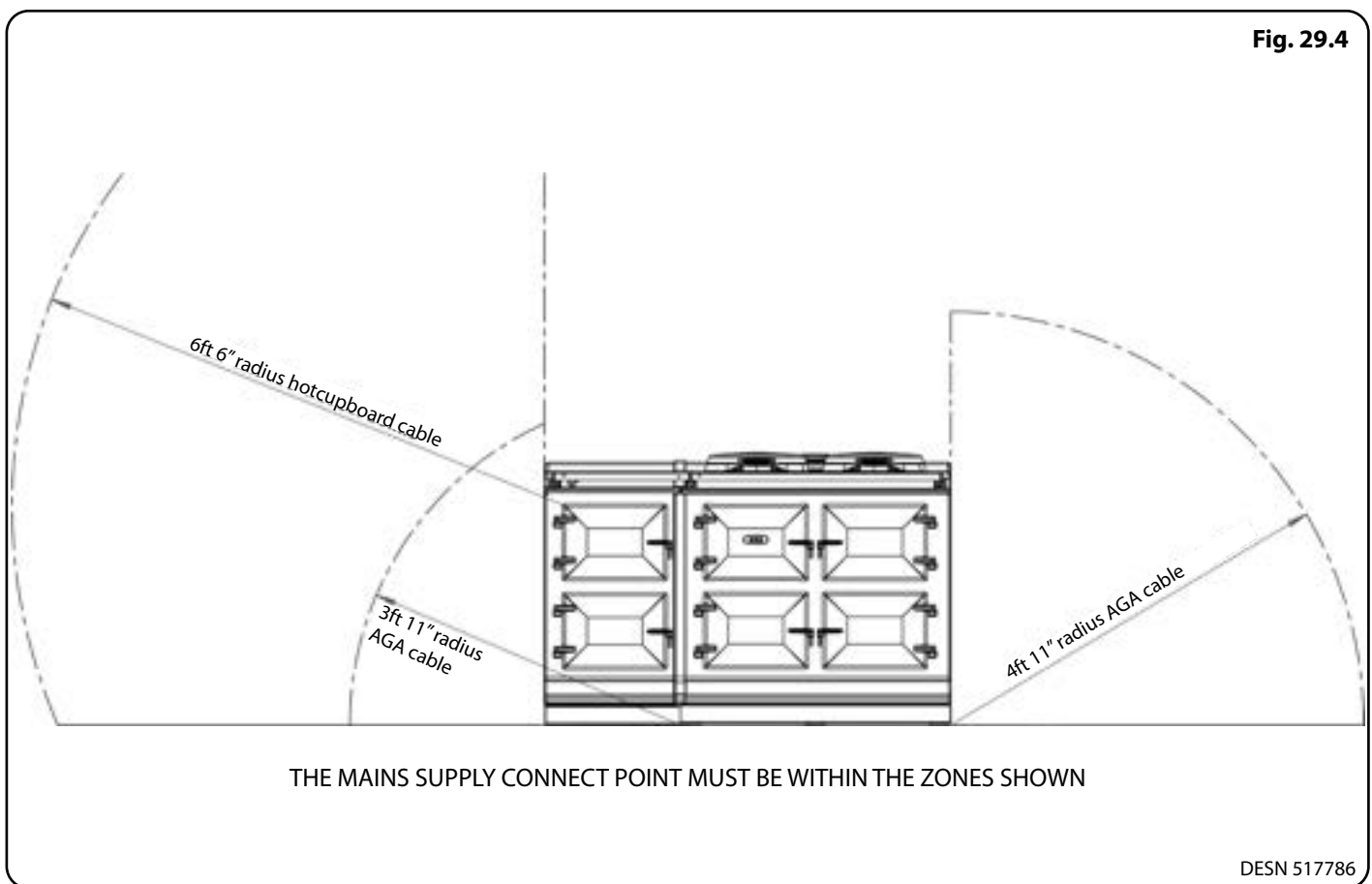
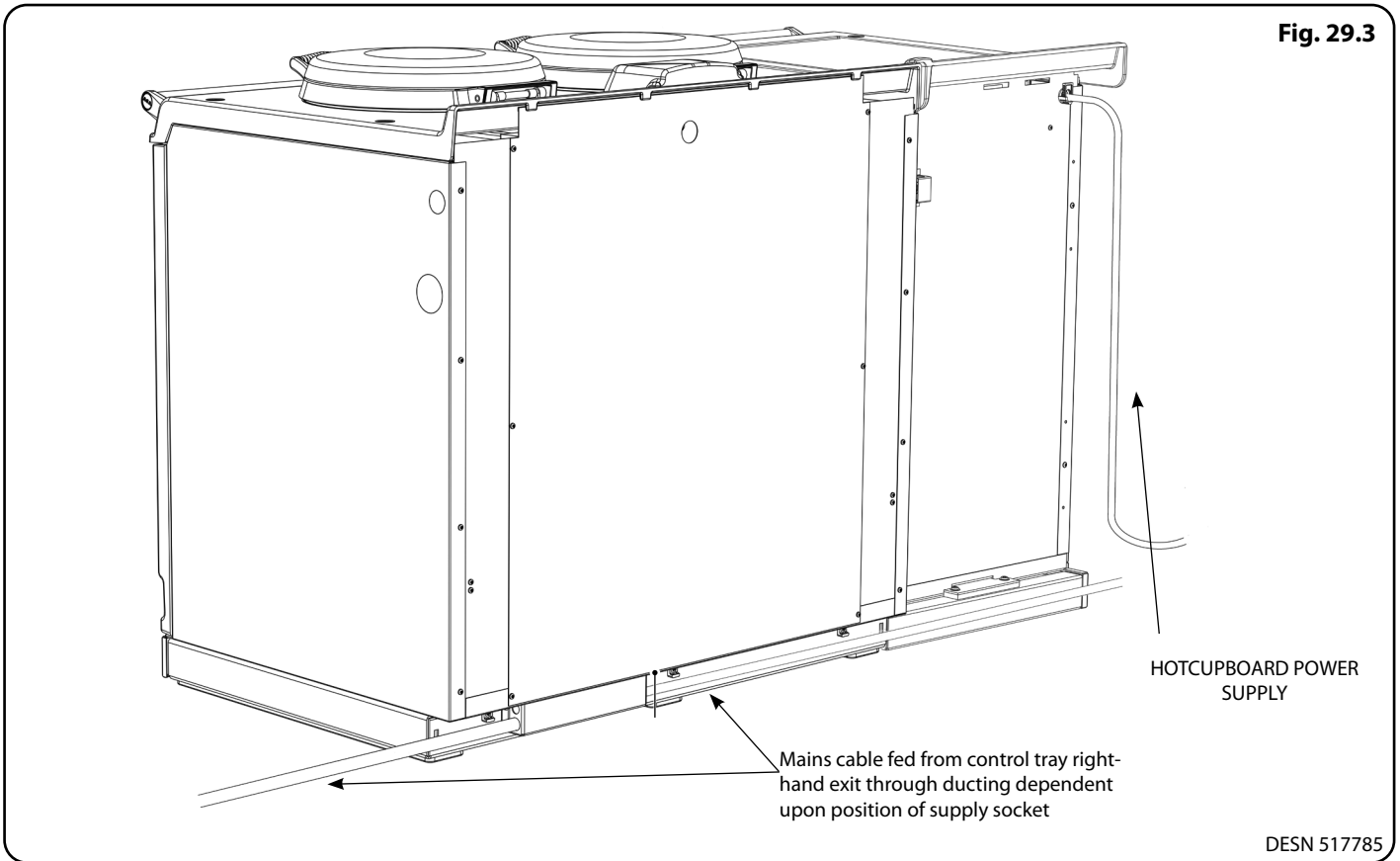

30. Hotcupboard installation

NOTE: The AGA hotcupboard should arrive with the top plate in a jacked up position (**except for induction top versions which will arrive with the top fully wound down**). This is to allow the complete appliance to be slid onto its plinth when alongside the AGA eR7 without the top plates clashing. The hotcupboard top plate should then be wound down to its correct height once the appliance is in its final position.

For induction top versions the top plate adjusters will need to be wound upwards before the hotcupboard can be fitted onto its plinth, in order to provide adequate clearance between the two top plates.

1. Detach hotcupboard from plinth by removing two screws and tongue bracket from plinth (**Fig. 30.1**), slide hotcupboard forwards and away from rear fixing bracket (**Fig. 30.2**).

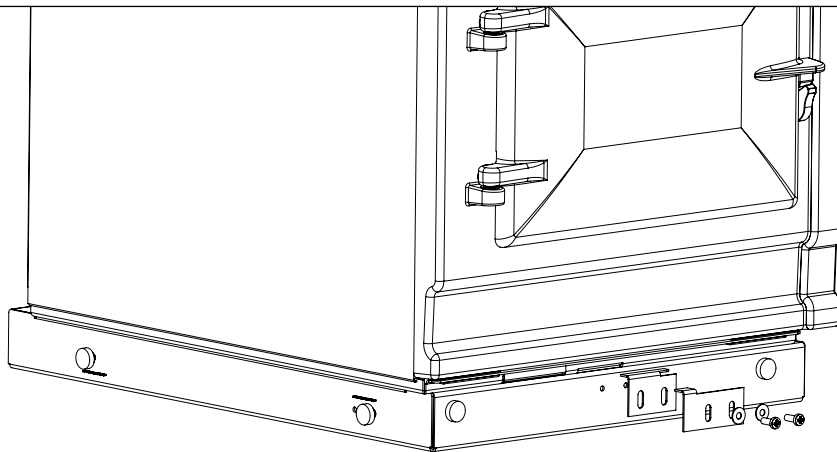

Fig. 30.1

DESN 517788

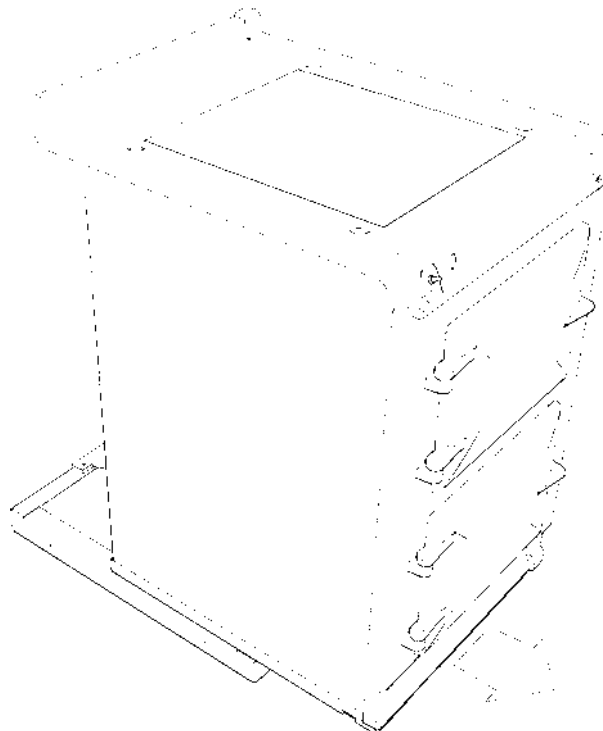
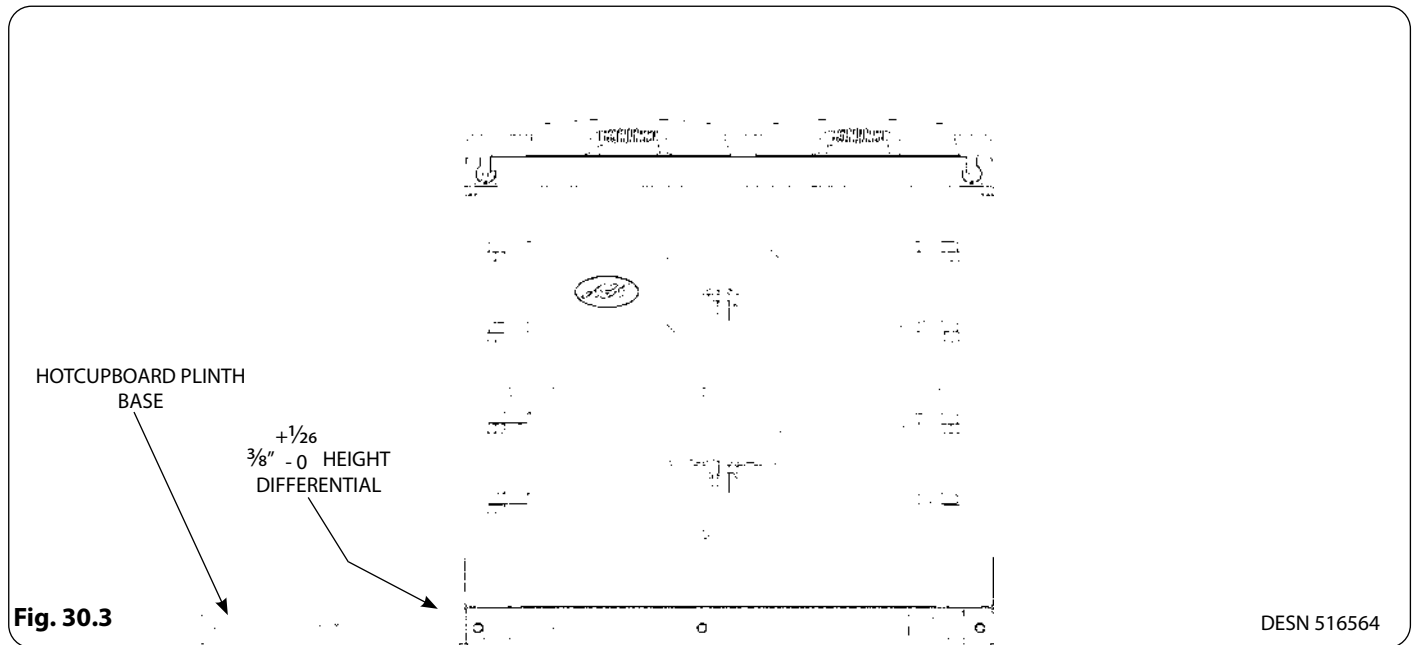

Fig. 30.2

DESN 516449

2. Position the plinth alongside the AGA eR7 leaving no gap between the two plinths (**Fig. 30.3**).

Check with a spirit level that the plinth level is correct, and also check height differential between the hotcupboard plinth and AGA eR7 plinth is correct $\frac{3}{8}$ " (11 mm). If necessary, use shims in each corner to level the plinth.



3. Attach hotcupboard plinth to the AGA eR7 plinth using M6 screws and washers provided (**Fig. 30.4**). Attach locking screw into plinth.

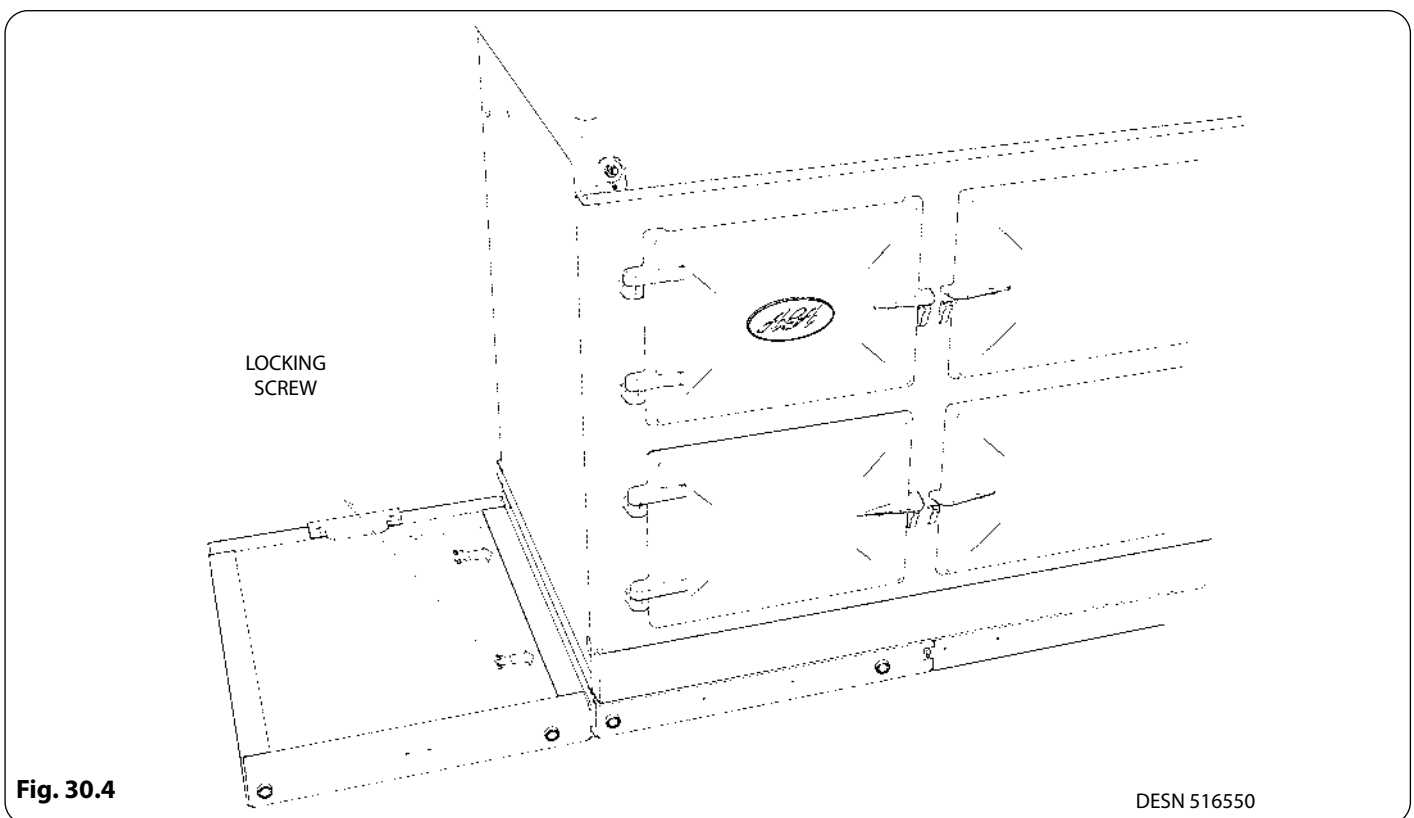

4. Run a straight edge along the front of the AGA eR7 plinth, to ensure the front face of both plinths sit squarely against the straight edge. (**Fig. 30.5**)

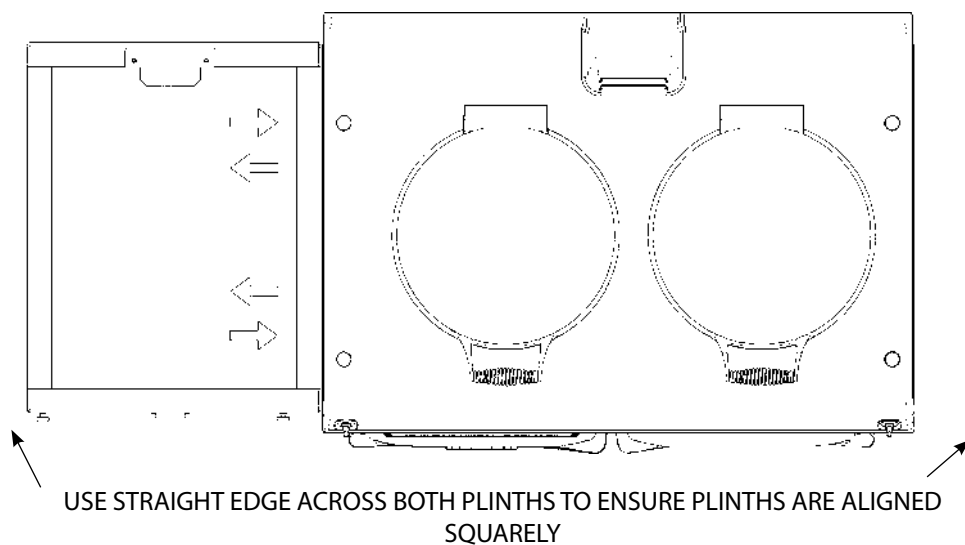

Fig. 30.5

DESN 516551

5. Front jointing bracket can now be hooked into place over the two pot magnets. This will latch the two plinths together. (**Fig. 30.6**)

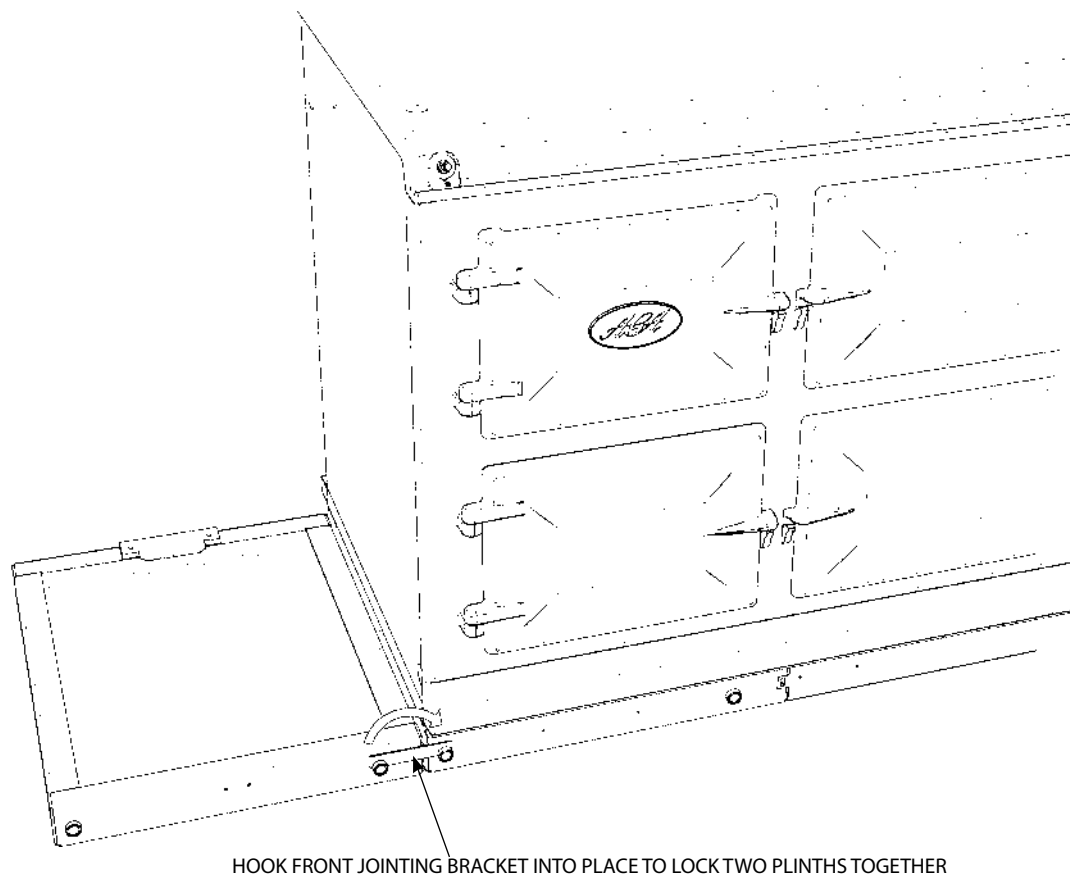

Fig. 30.6

DESN 516567

6. Slide hotcupboard onto plinth until rear tongue bracket engages fully into rear of base slot, (**Fig. 30.7**). Ensure the appliance is aligned squarely with the plinth then proceed to engage the front tongue bracket into the slot on the underside of the base plate. Once satisfied that the front tongue bracket is engaged fully lock it into place by tightening the two M6 screws fully.

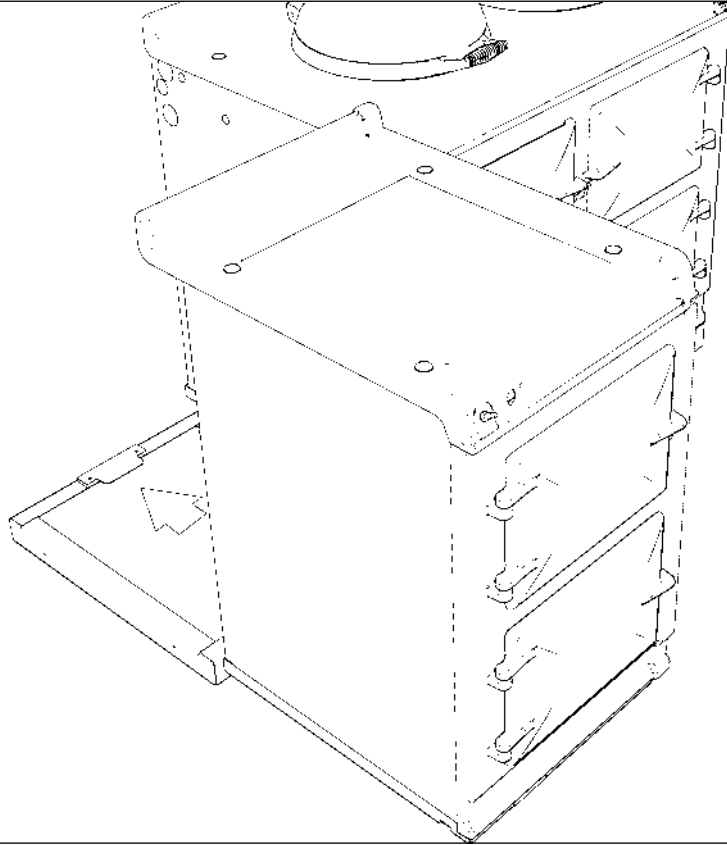

Fig. 30.7

DESN 516552

7. The hotcupboard top plate is set $\frac{3}{16}$ " (5mm) higher than the AGA eR7 top plate. This is to prevent damage to the enamel during installation. Lower the top plate using the adjusters (**Fig. 30.8** and **Fig. 30.9**).

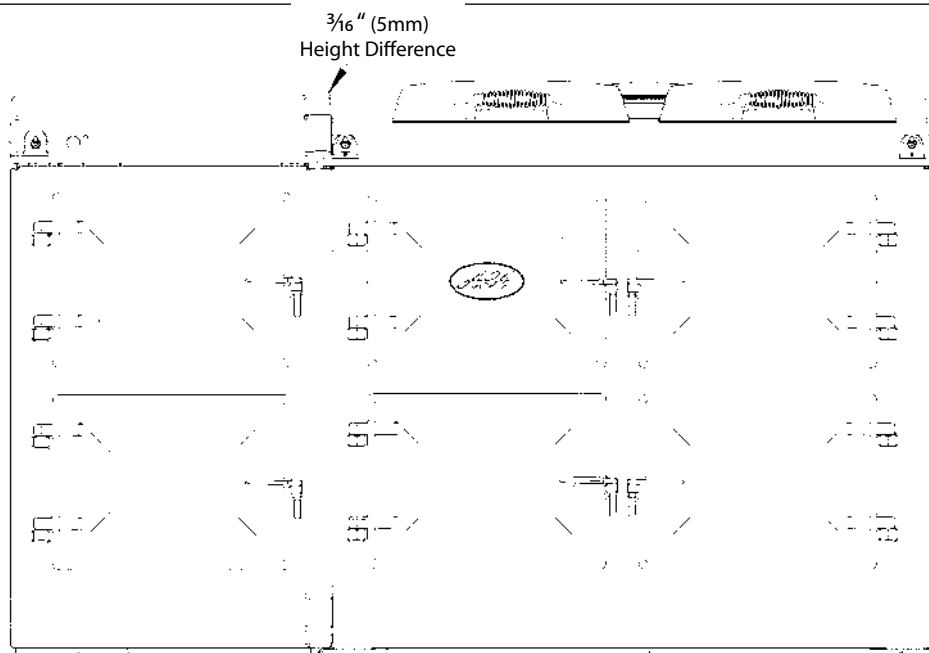

Fig. 30.8

DESN 516554

- Using the stay rod nut adjusting tool, carefully lower the top plate adjusting nuts until the top plate sits at the required height, making sure that the top sits level and matches the height of the AGA eR7. (**Fig. 30.9**).

For servicing requirement, top plate should be removed by raising adjusters approximately $\frac{3}{16}$ " (5mm), the top plate can now be removed easily without causing damage to the enamelled surfaces.

When removing the top plate, the switch wiring harness should be disconnected from the main wiring harness at the connection point located at the front left hand side of the appliance, beneath the formex cover sheet.

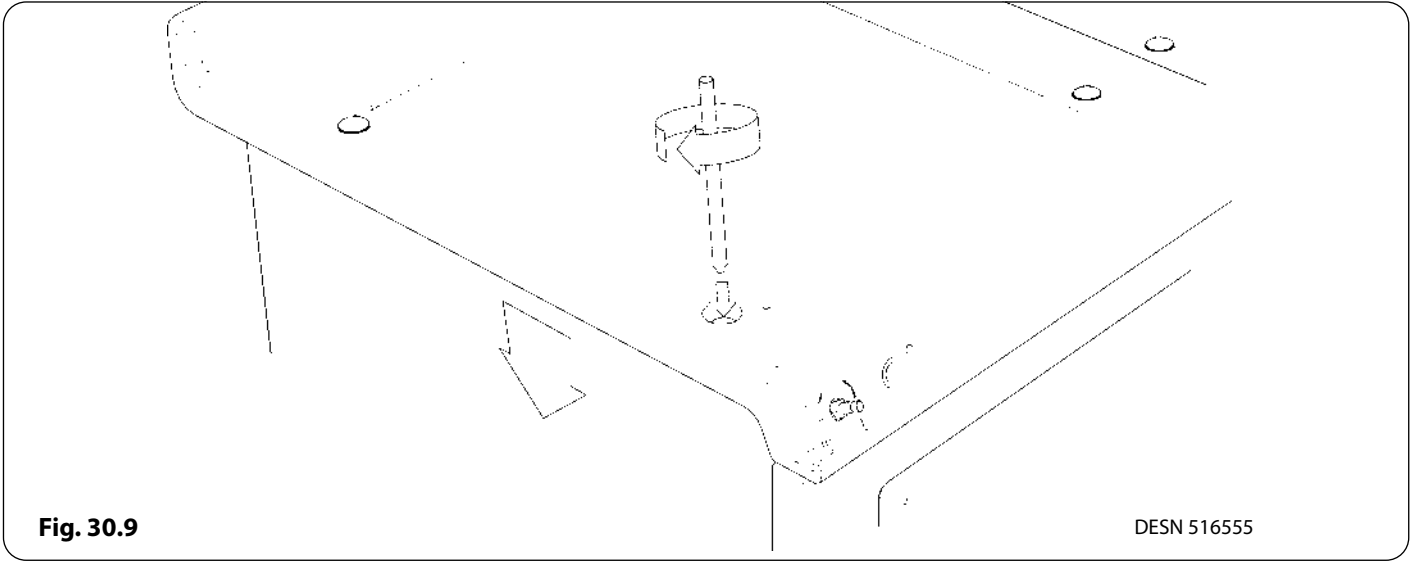

- Fit the handrail bracket over the fixing stud located on the top plate. Lock into position by tightening the grub screw nearest the appliance. (**Fig. 30.10**).

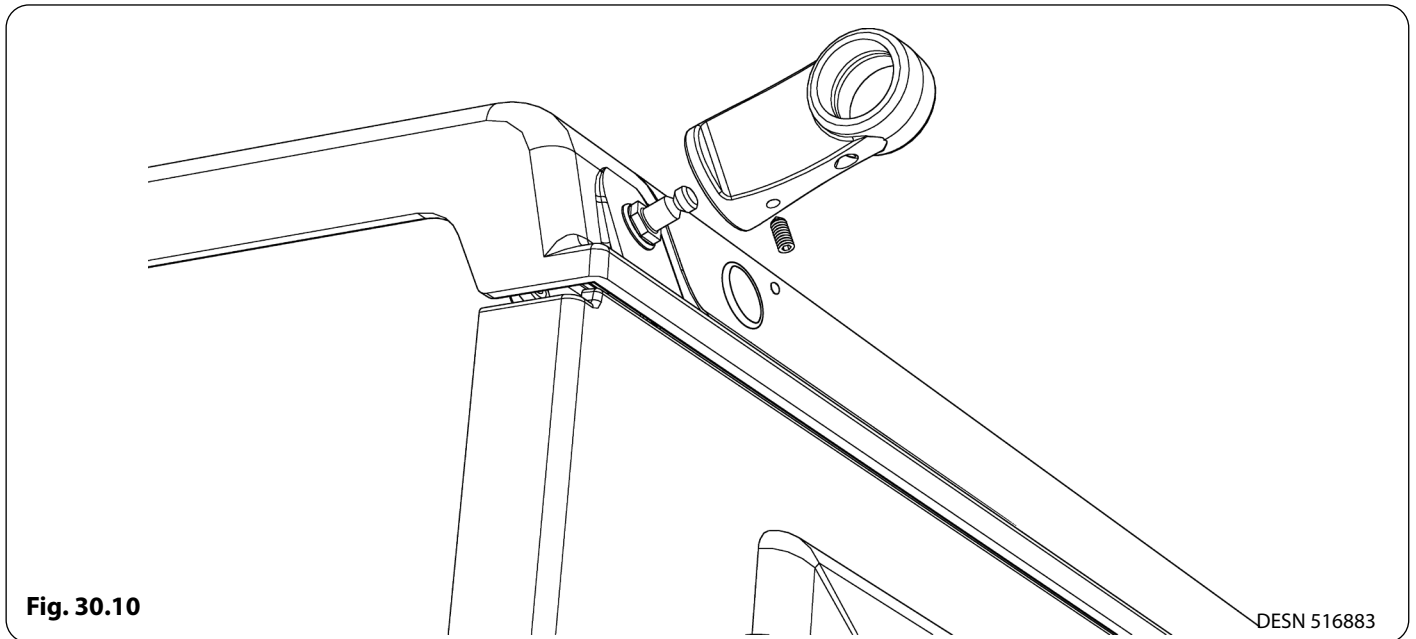

10. Next the handrail, endcaps and handrail require assembly. Slide the handrail through the handrail brackets.

AGA e7 HANDRAIL CONNECTION

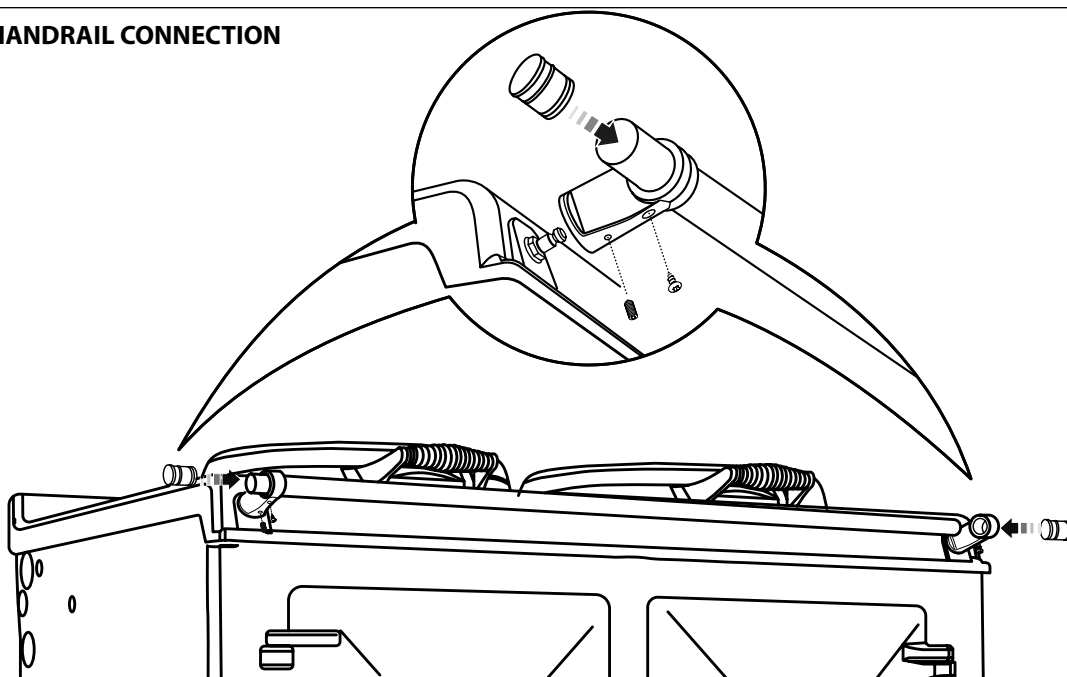

Fig. 30.11

DESN 516880

11. On 5 oven appliances, fit 'allthread' stud into the threaded end of the handrail, then feed the handrail through the bracket (ensuring that the allthread stud is protruding from the right hand side of the hotcupboard handrail) and screw the handrails together. (Fig. 30.12).

AGA e7 HANDRAIL CONNECTION

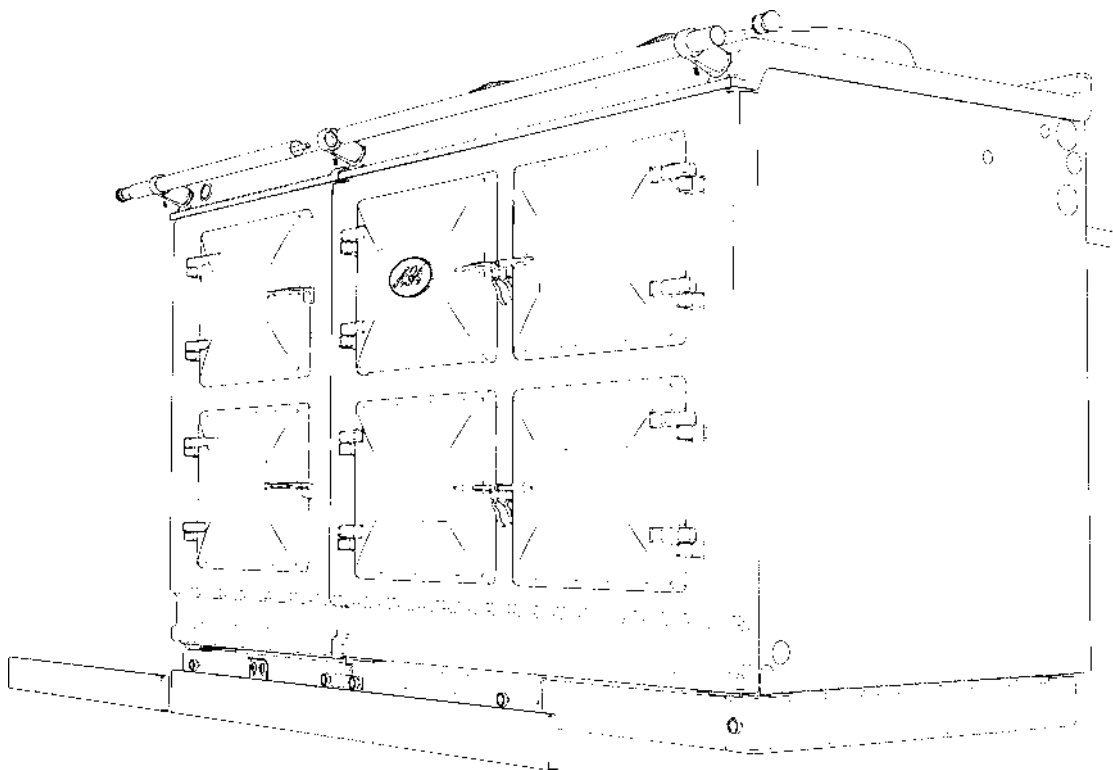

Fig. 30.12

DESN 516879

12. Once the handrail assembly is located squarely, lock the handrail in position by winding in the grub screws on the underside of each handrail bracket.
13. Once the handrails are locked in position, fit the handrail endcaps. The endcaps should be carefully pushed into place until they sit flush with the outside face of each bracket (a light smear of lubricant such as, washing up liquid on the end cap 'O' rings may ease fitment).
14. Finally, fit the plinth fascia to the magnets on the front of the plinth, making sure that on 5 oven appliances the right hand side of the module plinth fascia sits against the left hand side of the AGA eR7 plinth fascia leaving no gap between. Make sure that the plinth fascias are centrally located and do not overhang either appliance.
(Fig. 30.12)

Commission the AGA eR7, as stated in the relevant Installation Instructions and carry out functional test on each of the features of the AGA eR7.

31. Circuit Diagram

AGA Hotcupboard

⚠ Caution: label all wires prior to disconnection, when servicing controls wiring errors can cause improper and dangerous operation.

⚠ Verify proper operation after servicing

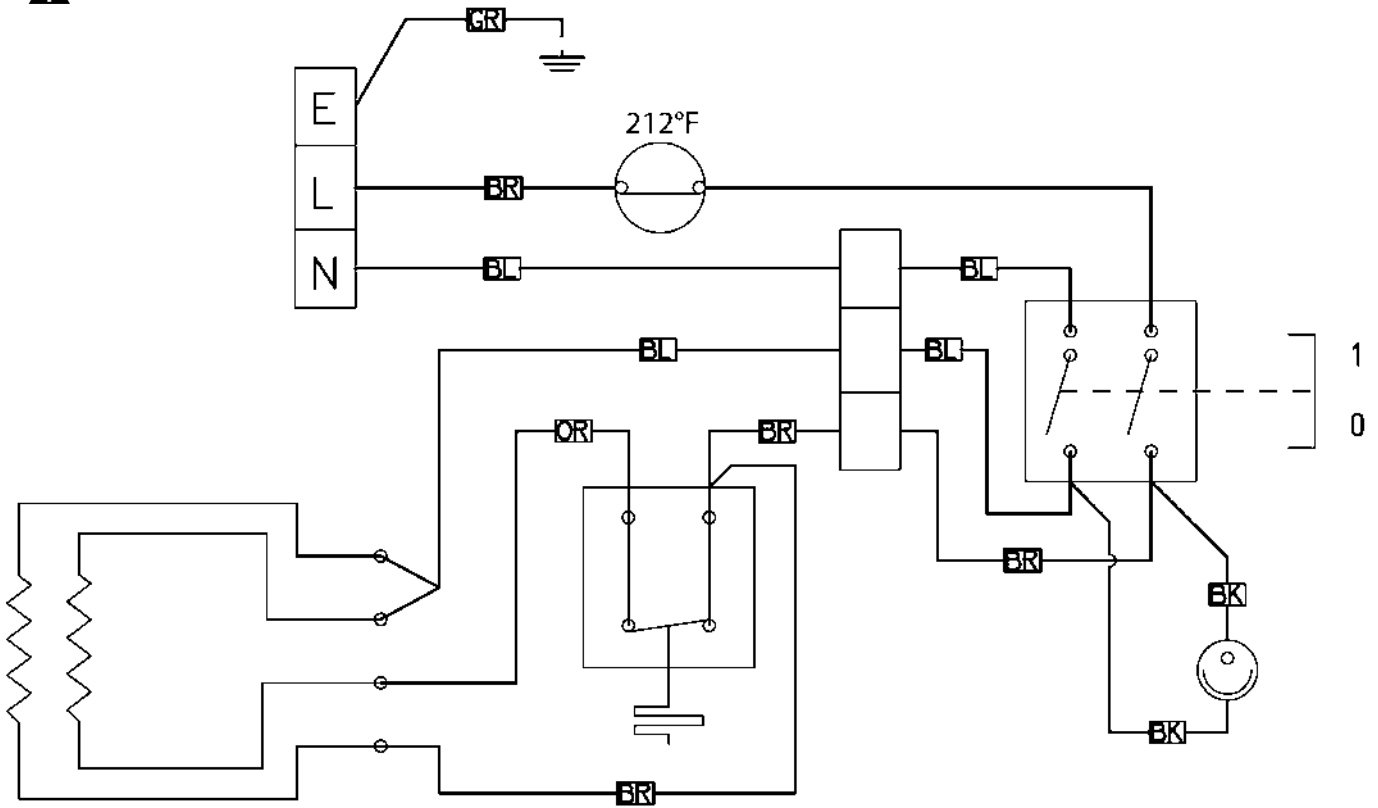

DESN 517488

Code	Colour
B	Blue
BR	Brown
BL	Black
OR	Orange
G	Green

AGA eR7

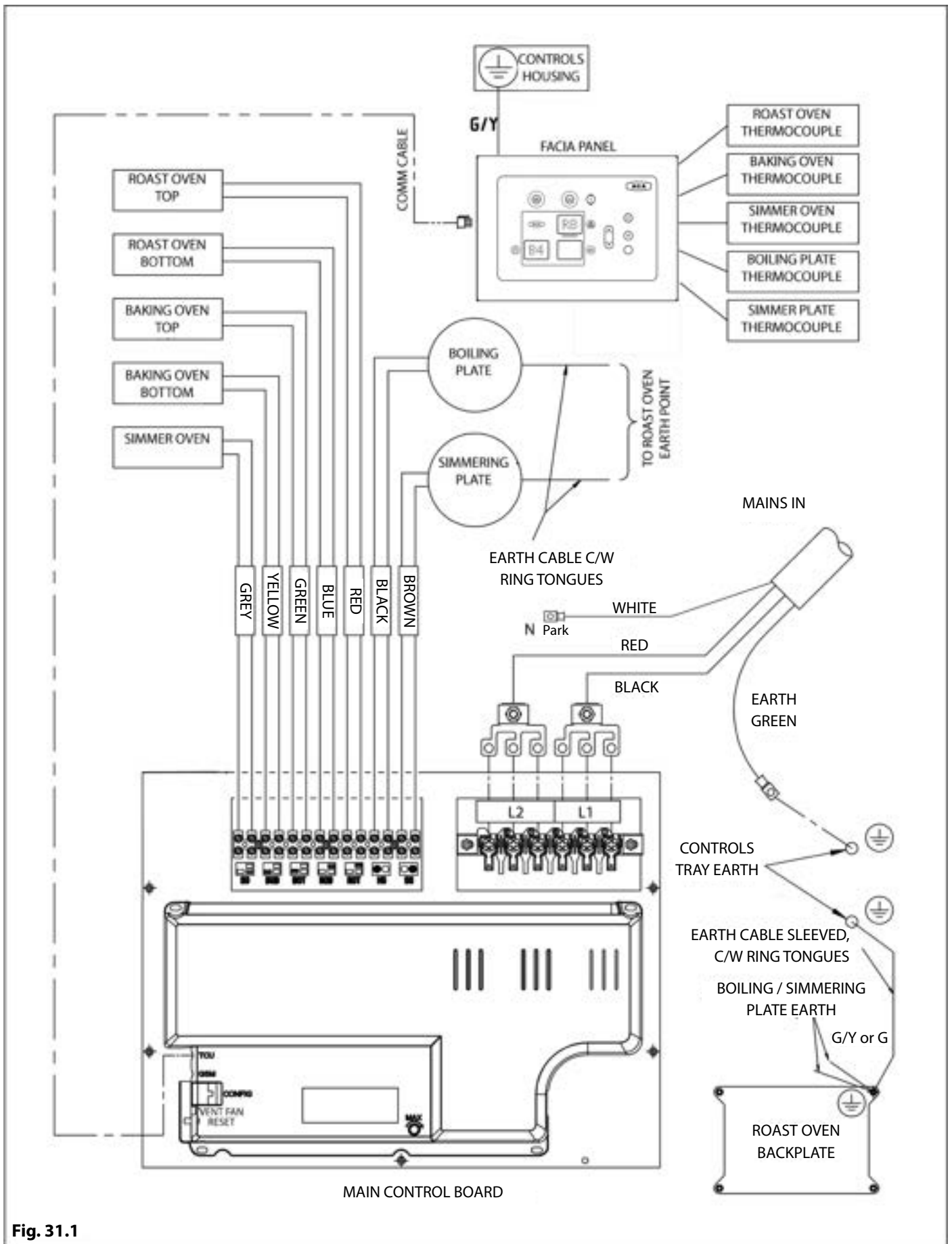

Fig. 31.1

**For further advice or information contact
your local AGA Specialist**

With AGA Marvel's policy of continuous product improvement, the Company reserves the right to change specifications and make modifications to the appliance described and illustrated at any time.



Middleby Residential

4960 Golden Pkwy

BLDG 3

Buford, GA 30518

Business 770.932.7282

Fax 770.932.7292

Toll Free Telephone 800.241.9152