



FRIEDRICH

Room Air Conditioners

Kühl®

Kühl® Q

Wallmaster®

R-32 Refrigerant

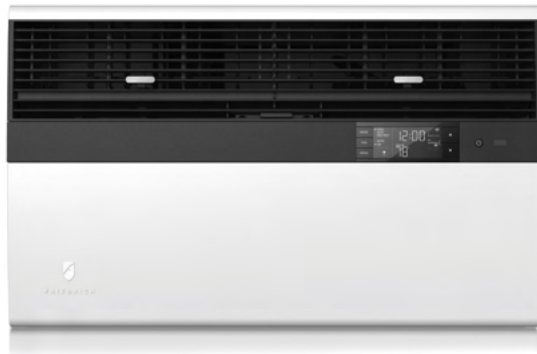

Kühl® 115-Volt: KCS12B10A, KHS10B10A
230-Volt: KCM24B30A, KCL28B30A, KCL36B30A

Kühl® Q 115-Volt: KCQ08B10A

Wallmaster® WCT16B30A

THE EXPERTS IN ROOM AIR CONDITIONING

TABLE OF CONTENTS

Table of Contents

TABLE OF CONTENTS	2
INTRODUCTION	4
Important Safety Information	4
Personal Injury Or Death Hazards	6
Control Options	8
Component Identification	9
User Interface	9
Model And Serial Number Location	10
Model Number Reference Guide	11
Serial Number Reference Guide	12
SPECIFICATIONS	13
Dimensions	14
Electrical Data	15
Electrical Data -Power Cord	16
OPERATION	17
Airflow Selection and Adjustment -Kuhl	17
Airflow Selection and Adjustment -Kuhl Q	18
Airflow Selection and Adjustment -Wallmaster	19
User Interface-Kuhl	20
User Interface - Kuhl Q	21
User Interface- Wallmaster	22
User Interface - All Models	23
Control Panel	34
Remote Control	35
Unit	36
Unit Cooling Mode	37
Unit Heat Control Operation - Heat Pump Only Unit	38
General Knowledge Sequence Of Refrigeration	40
Routine Maintenance	41
Remove and Install Front Cover -Kuhl	41
Routine Maintenance	42
Remove and Install Front Cover -Kuhl Q	42
Routine Maintenance	43
Remove and Install Front Cover -Wallmaster	43
Standard Filter Removal / Installation Instructions - Kuhl	45
Premium Carbon Filter Removal / Installation Instructions -Kuhl	46
Filter Removal / Installation Instructions - Kuhl Q	47
REMOVE AND INSTALL THE CHASSIS	48
Remove The Chassis - Kuhl	48
Install The Chassis -Kuhl	49
Kuhl Q	50
Wallmaster	51
TROUBLESHOOTING	52
Room Air Conditioner Unit Performance Test Data Sheet	52
Cooling Sizing Guide	52
Diagnostic Codes	53
Troubleshooting Tips	54
COMPONENT TESTING	62
Capillary Tube and Check Valve Assy (Heat Pump Units)	62
Capillary Tube Assy (Cool Only Units)	63
Reversing Valve Description And Operation	64
Testing The Reversing Valve Solenoid Coil	65
Checking The Reversing Valve	66
Touch Test Chart : To Service Reversing Valves	67
Compressor Checks	68
Fan Motor	70
Checking Capacitors	71
Thermistors Description	72
Test User Interface and Electronic Control Board	73
Electronic Control Board Identification	73
Replace the Electronic Control Board- Kuhl	74
Replace the User Interface	74
Replace the Electronic Control Board- Kuhl Q	75
Replace the User Interface	75

Replace the User Interface - Wallmaster	76
Replace the Electronic Control Board - Wallmaster	77
R-32 SEALED SYSTEM REPAIR	78
General Information	78
Required Equipment	80
Refrigerant Removal, Recovery, and Evacuation	81
Component Replacement/Brazing	82
Refrigerant Charging	83
Compressor Replacement	84
Compressor Replacement -Special Procedure in Case of Compressor Burnout	85
Replace The Reversing Valve	86
WIRING DIAGRAMS	87
Available Accessories	93
APPENDIX	94
Interactive Parts Viewer	94
Limited Warranty	94
Thermistor Resistance Values (This Table Applies to All Thermistors)	95
Friedrich Authorized Parts Depots	96

INTRODUCTION

Important Safety Information

The information in this manual is intended for use by a qualified technician who is familiar with the safety procedures required for installation and repair, and who is equipped with the proper tools and test instruments required to service this product.

Installation or repairs made by unqualified persons can result in subjecting the unqualified person making such repairs as well as the persons being served by the equipment to hazards resulting in injury or electrical shock which can be serious or even fatal.

Maintenance is the responsibility of the owner. Failure to properly maintain or repair equipment may result in personal injury and/or various types of property damage (fire, flood, etc.).

Safety warnings have been placed throughout this manual to alert you to potential hazards that may be encountered. If you install or perform service on equipment, it is your responsibility to read and obey these warnings to guard against any bodily injury or property damage which may result to you or others.

Due to continuing research in new energy-saving technology, all information in this manual is subject to change without notice.

This service manual is designed to be used in conjunction with the installation and operation manuals provided with each air conditioning system.

This service manual was written to assist the professional service technician to quickly and accurately diagnose and repair malfunctions.

Installation procedures are not given in this manual. They are given in the Installation/Operation manual which can be acquired on the Friedrich [website](#). Click the Link or scan the QR code to be directed to the Professional page where you can locate our technical literature.



SAFETY IS IMPORTANT

We have provided many important safety messages in this manual and on your appliance. Always read and obey all safety messages.



This is a safety Alert symbol. This symbol alerts you to potential hazards that can kill or hurt you and others.

All safety messages will tell you what the potential hazard is, tell you how to reduce the chance of injury, and tell you what will happen if the instructions are not followed.

All safety messages will follow the safety alert symbol with the word "WARNING" or "CAUTION". These words mean:



WARNING Indicates a hazard which, if not avoided, can result in severe personal injury or death and damage to product or other property.



CAUTION Indicates a hazard which, if not avoided, can result in personal injury and damage to product or other property.

NOTICE

Indicates property damage can occur if instructions are not followed.



This symbol indicates that this appliance uses a flammable refrigerant. If the refrigerant is leaked and is exposed to an external ignition source, there is a risk of fire.



This symbol indicates that the Operation Manual should be read carefully.



This symbol indicates that service personnel should be handling this equipment with reference to the installation manual.



This symbol indicates that information is available such as the Installation and Operation manual, or the Service Manual.

INTRODUCTION

⚠️ WARNING: The manufacturer's warranty does not cover any damage or defect to the air conditioner caused by the attachment or use of any components, accessories or devices (other than those authorized by the manufacturer) into, onto or in conjunction with the air conditioner. You should be aware that the use of unauthorized components, accessories or devices may adversely affect the operation of the air conditioner and may also endanger life and property. The manufacturer disclaims any responsibility for such loss or injury resulting from the use of such unauthorized components, accessories or devices.

⚠️ WARNING: This appliance is not intended for use by persons (Including children) with reduced physical, sensory or mental capabilities, or lack of experience and knowledge, unless they have been given supervision or instruction concerning use of the appliance by a person responsible for their safety.

Children should be supervised to ensure that they do not play with the appliance.

⚠️ WARNING: The maximum altitude for this appliance is 2,000 meters(6,562 feet).

Do not use above 2,000 meters(6,562 feet).

⚠️ WARNING: Electrical Shock Hazard

Disconnect all power to the unit before starting maintenance. All electrical connections and wiring **MUST** be installed by a qualified electrician and conform to the National Code and all local codes which have jurisdiction. Failure to do so can result in property damage, severe electrical shock or death.



⚠️ WARNING: Read Installation Manual

Read this manual thoroughly prior to equipment installation or operation. It is the installer's responsibility to properly apply and install the equipment. Installation must be in conformance with the NFPA 70-2023 national electric code or current edition, International Mechanic code 2021 or current edition, and any other local or national codes.



⚠️ WARNING: Safety First

Do not remove, disable, or bypass this unit's safety devices. Doing so may cause fire, injuries, or death.

⚠️ WARNING: This Product uses R-32 Refrigerant

Do not use means to accelerate the defrosting process or to clean, other than those recommended by the manufacturer.

The appliance shall be stored in a room without continuously operating ignition sources (for example: open flames, an operating gas appliance or an operating electric heater).

Do not pierce or burn.

Be aware that refrigerants may not contain an odor.



Refrigerant
Safety Group
A2L

⚠️ WARNING: Refrigeration System under High pressure

Do not puncture, heat, expose to flame or incinerate. Only certified refrigeration technicians should service this equipment. R32 systems operate at higher pressures than R22 equipment. Appropriate safe service and handling practices must be used.



⚠️ CAUTION: Do Not Operate Equipment During Active Stages Of Construction



To ensure proper operation, Friedrich requires that all equipment is not operated during active construction phases. This includes active stages of completing framing, drywalling, spackling, sanding, painting, flooring, and moulding in the equipment's designated conditioning space. The use of this equipment during construction could result in premature failure of the components and/or system and is in violation of our standard warranty guidelines. The operation of newly installed equipment during construction will accelerate the commencement and/or termination of the warranty period.

⚠️ WARNING: Keep all air circulation and ventilation openings free from obstruction.

⚠️ WARNING: The unit should not be in contact with any equipment that will transmit vibration to the unit. Any excessive vibration or pulsation to the unit could result in damage to the refrigerant tubing.

INTRODUCTION

Personal Injury Or Death Hazards

	 WARNING	 AVERTISSEMENT	 ADVERTENCIA
SAFETY FIRST	Do not remove, disable or bypass this unit's safety devices. Doing so may cause fire, injuries, or death.	Ne pas supprimer, désactiver ou contourner cette l'unité des dispositifs de sécurité, faire vous risqueriez de provoquer le feu, les blessures ou la mort.	No eliminar, desactivar o pasar por alto los dispositivos de seguridad de la unidad. Si lo hace podría producirse fuego, lesiones o muerte.

 WARNING
ALWAYS USE INDUSTRY STANDARD PERSONAL PROTECTIVE EQUIPMENT (PPE)

ELECTRICAL HAZARDS:

- Unplug and/or disconnect all electrical power to the unit before performing inspections, maintenance, or service.
- Make sure to follow proper lockout/tag out procedures.
- Always work in the company of a qualified assistant if possible.
- Capacitors, even when disconnected from the electrical power source, retain an electrical charge potential capable of causing electric shock or electrocution.
- Handle, discharge, and test capacitors according to safe, established, standards, and approved procedures.
- Extreme care, proper judgment, and safety procedures must be exercised if it becomes necessary to test or troubleshoot equipment with the power on to the unit.
- Do not spray water on the air conditioning unit while the power is on.
- Electrical component malfunction caused by water could result in electric shock or other electrically unsafe conditions when the power is restored and the unit is turned on, even after the exterior is dry.
- Use air conditioner on a single dedicated circuit within the specified amperage rating.
- Use on a properly grounded outlet only.
- Do not cut or modify the power supply cord or remove the ground prong of the plug.
- Never operate the unit on an extension cord.
- Follow all safety precautions and use proper and adequate protective safety aids such as: gloves, goggles, clothing, properly insulated tools, and testing equipment etc.
- Failure to follow proper safety procedures and/or these warnings can result in serious injury or death.

INTRODUCTION

PERSONAL INJURY OR DEATH HAZARDS

- **REFRIGERATION SYSTEM REPAIR HAZARDS:**

- Use approved standard refrigerant recovering procedures and equipment to relieve high pressure before opening system for repair. Reference EPA regulations (40 CFR Part 82, Subpart F) Section 608.
- Do not allow liquid refrigerant to contact skin. Direct contact with liquid refrigerant can result in minor to moderate injury.
- Be extremely careful when using an oxy-acetylene torch. Direct contact with the torch's flame or hot surfaces can cause serious burns.
- Make certain to protect personal and surrounding property with fire proof materials and have a fire extinguisher at hand while using a torch.
- Provide adequate ventilation to vent off toxic fumes, and work with a qualified assistant whenever possible.
- Always use a pressure regulator when using dry nitrogen to test the sealed refrigeration system for leaks, flushing etc.

- **MECHANICAL HAZARDS:**

- Extreme care, proper judgment and all safety procedures must be followed when testing, troubleshooting, handling, or working around unit with moving and/or rotating parts.
- Be careful when, handling and working around exposed edges and corners of the sleeve, chassis, and other unit components especially the sharp fins of the indoor and outdoor coils.
- Use proper and adequate protective aids such as: gloves, clothing, safety glasses etc.
- Failure to follow proper safety procedures and/or these warnings can result in serious injury or death.

- **PROPERTY DAMAGE HAZARDS**

- **FIRE DAMAGE HAZARDS:**

- Read the Installation/Operation Manual for the air conditioning unit prior to operating.
- Use air conditioner on a single dedicated circuit within the specified amperage rating.
- Connect to a properly grounded outlet only.
- Do not remove ground prong of plug.
- Do not cut or modify the power supply cord.
- Do not use extension cords with the unit.
- Be extremely careful when using acetylene torch and protect surrounding property.
- Failure to follow these instructions can result in fire and minor to serious property damage.

- **WATER DAMAGE HAZARDS:**

- Improper installation, maintenance or servicing of the air conditioner unit can result in water damage to personal items or property.
- Insure that the unit has a sufficient pitch to the outside to allow water to drain from the unit.
- Do not drill holes in the bottom of the drain pan or the underside of the unit.
- Failure to follow these instructions can result in damage to the unit and/or minor to serious property damage.

INTRODUCTION

Control Options

A variety of options for control, programming, and scheduling including wireless capabilities.

Wireless Programming and Control:

Friedrich Connect allows you to conveniently control, program, and monitor your air conditioning unit remotely from a smartphone or computer.

Programmable Timer Options:

Your unit's digital control comes equipped with a 24-hour timer.

The 24-hour timer allows you to set 2 temperature changes at pre-set times on the unit control panel.

Customizable Programming Options:

Customizable timers, with up to four temperature adjustments per day, can be set using Friedrich Connect for one or multiple units.

This service manual is designed to be used in conjunction with the installation and operation manuals provided with each air conditioning system.

This service manual was written to assist the professional service technician to quickly and accurately diagnose and repair malfunctions.

Due to continuing research in new energy-saving technology, all information in this manual is subject to change without notice.

IMPORTANT: It will be necessary for you to accurately identify the unit you are servicing, so you can be certain of a proper diagnosis and repair.

INTRODUCTION

Component Identification

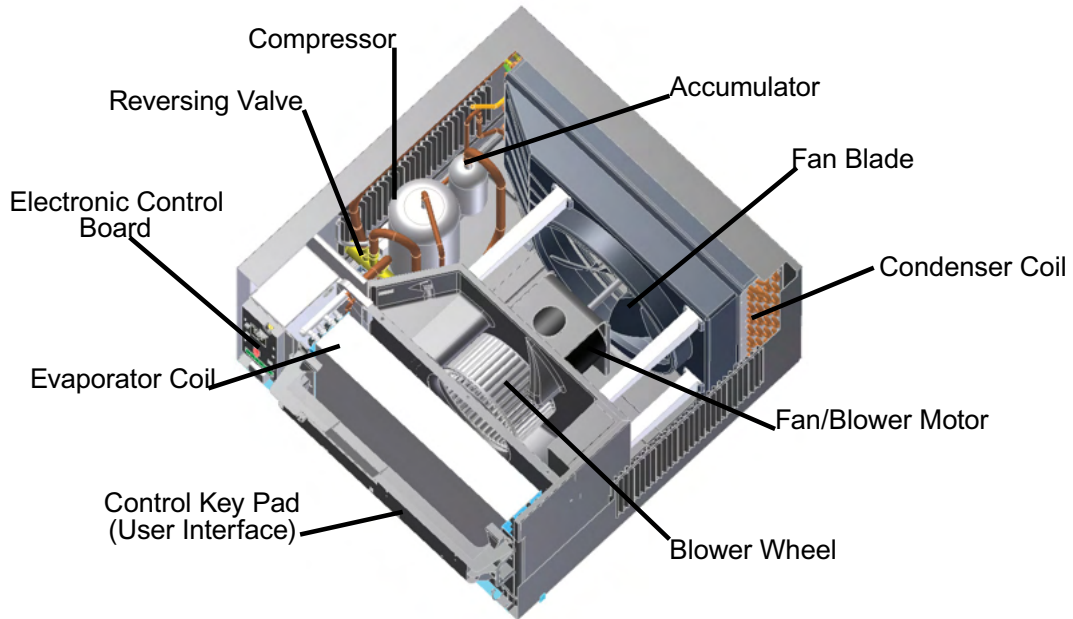

Figure 101 (Kuhl Component Identification)

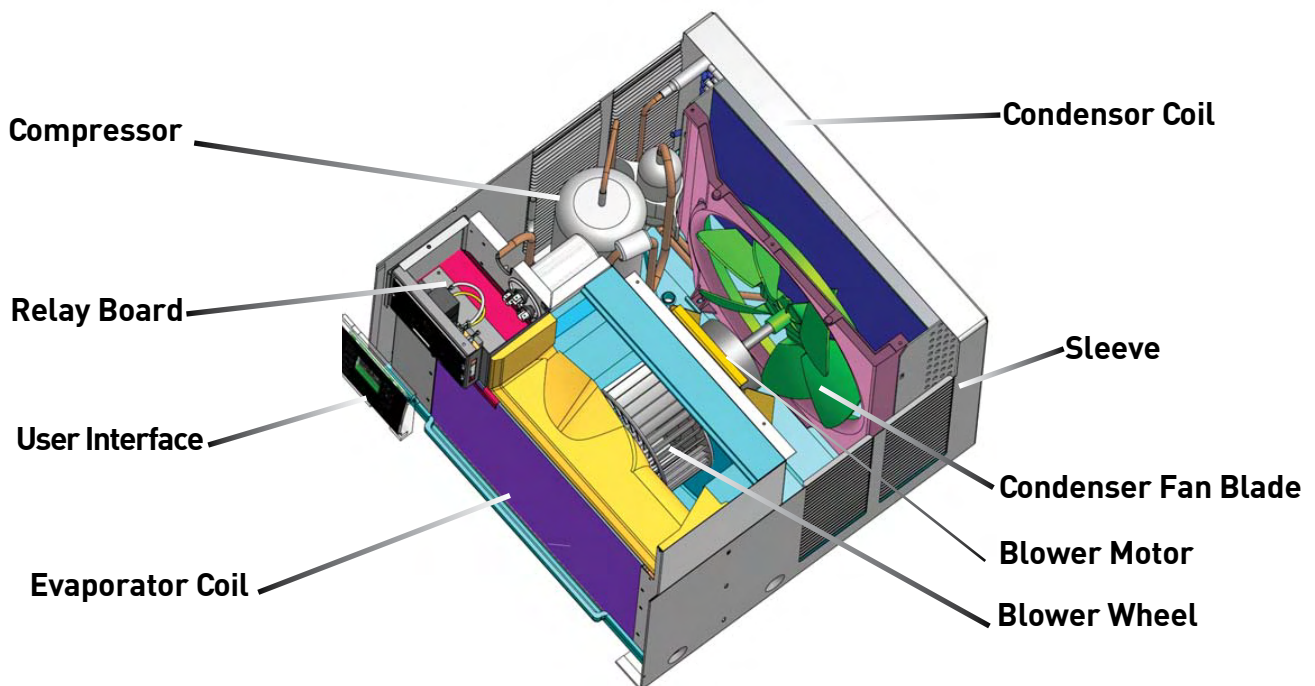

Figure 102 (Kuhl Q Component Identification)

INTRODUCTION

Model And Serial Number Location

IMPORTANT: It will be necessary for you to accurately identify the unit you are servicing, so you can be certain of a proper diagnosis and repair.

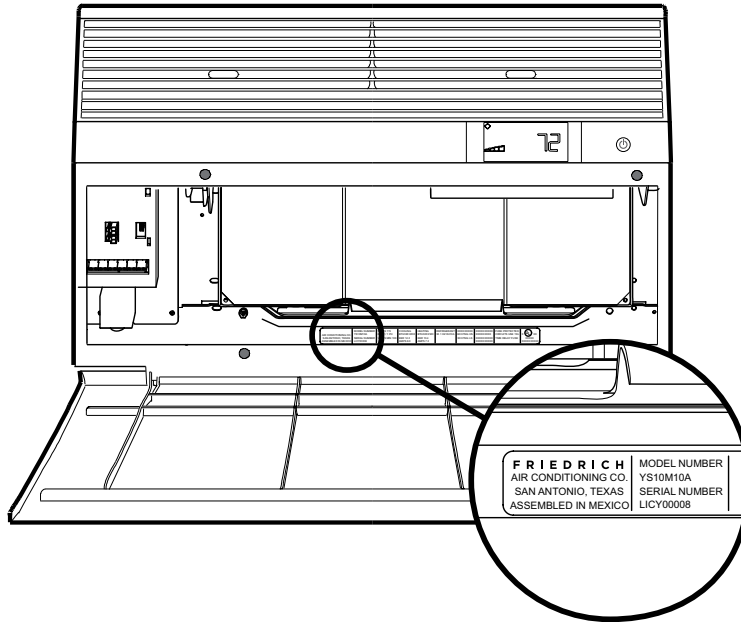

Figure 103 (Kuhl Model and Serial Number Location)

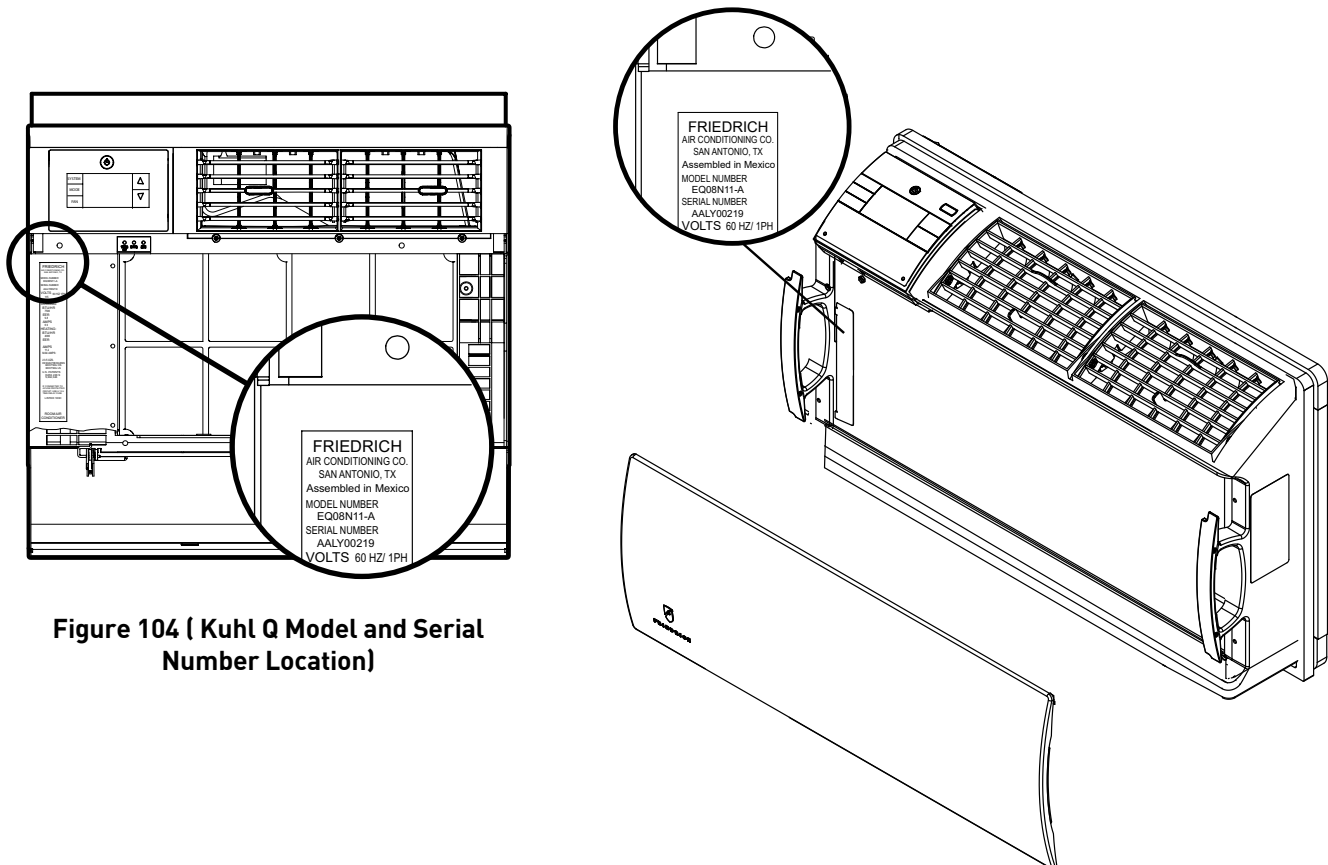
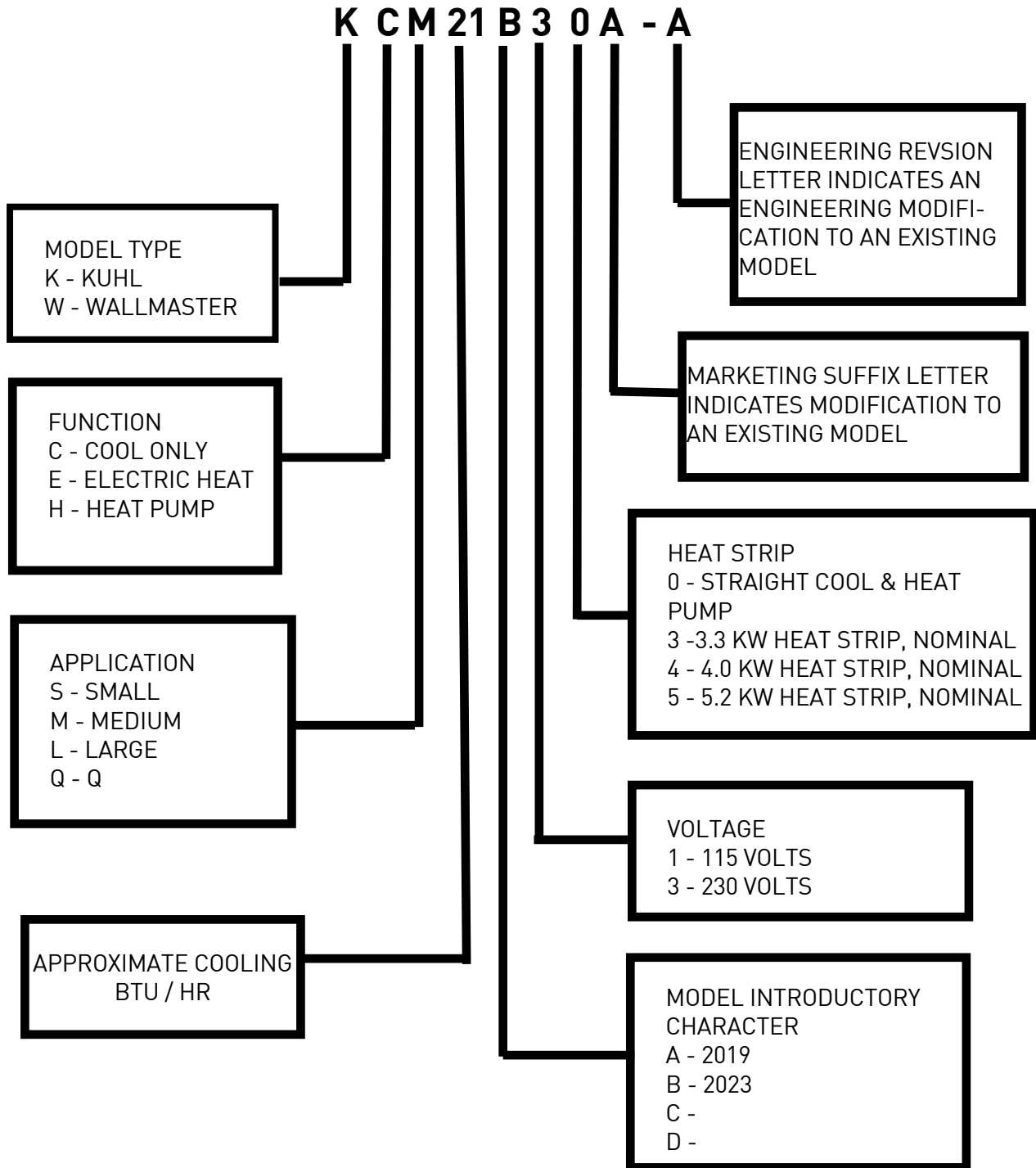

Figure 104 (Kuhl Q Model and Serial Number Location)

Figure 105 (Wallmaster Model and Serial Number Location)

INTRODUCTION

Model Number Reference Guide



IMPORTANT: It will be necessary for you to accurately identify the unit you are servicing, so you can be certain of a proper diagnosis and repair.

Figure 106 (Model Number Reference Guide)

INTRODUCTION

Serial Number Reference Guide

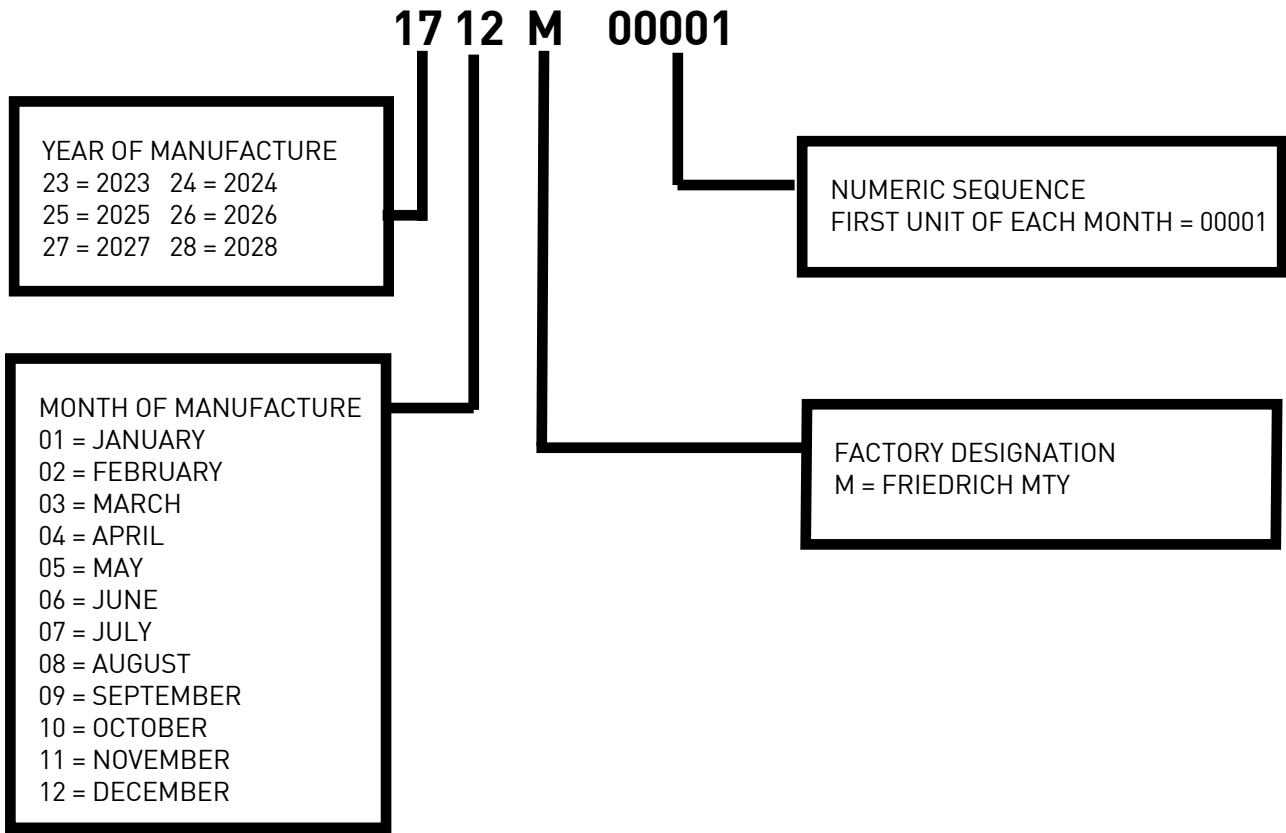

Figure 107 (Serial Number Reference Guide)

SPECIFICATIONS

Model	Cooling Btu	Heating Btu	Volts	Cooling Amps	Cooling Watts	Heating Amps	Heating Watts	EER	REFRIGERANT CHARGE (OZ.)	CEER	Estimated yearly Energy Cost
Kuhl Cooling Only Units											
KCS12B10A	12000		115	11.1	992			12.1	20	12	\$98
KCM24B30A	23800		230	13.8	2308			10.4	26	10.3	\$225
KCL28B30A	27100		230	16	2606			10.4	40	10.3	\$255
KCL36B30A	36000		230	23.6	3956			9.1	46	9	\$392
Kuhl Heat Pump Units											
KHS10B10A	10000	8500	115	9.3	826	9.8	804	12.1	19	12	\$81
Kuhl Q Cooling Only Units											
KCQ08B10A	8000		115	7.2	661			12.1	14	12	\$65
Wallmaster Cooling Only Units											
WCT16B30A	15400		230	9.2	1638			9.4	23	9.3	\$161
<p>* KHS10A10A heat pump operates on 115 volt and is not equipped with supplemental heat. Will not provide heat at temperatures below 40°F. Friedrich room air conditioners are designed to operate in cooling mode with outdoor temperatures from 60°F to 115°F.</p> <p>**Rating Conditions: 80 degrees F, room air temp. & 50% relative humidity, with 95 degree F, outside air temp & 40% relative humidity, all systems use R-410A. Test done at highest unit fan speed.</p>											

Figure 201(Specifications)

SPECIFICATIONS

Dimensions

Sleeve	Height Inches	Width Inches	Depth with Front	Shell Depth to Louvers	Minimum Extension Into Room*	Minimum Extension Outside * Inches	Window Width INCHES		In-wall Installation Finished Hole Inches			Carton Dimensions Inches		
			A	B	Inches	Inches	Minimum**	Maximum	Height	Width	Max. Depth C	Height	Width	Depth
S	15 ¹⁵ / ₁₆ "	25 ¹⁵ / ₁₆ "	29"	8 ³ / ₄ "	5 ³ / ₄ "	16 ¹⁵ / ₁₆ "	27 ³ / ₈ "	42"	16 ³ / ₁₆ "	26 ³ / ₁₆ "	7 ³ / ₈ "	19"	29"	34 ¹ / ₂ "
M	17 ¹⁵ / ₁₆ "	25 ¹⁵ / ₁₆ "	29"	8 ³ / ₄ "	5 ³ / ₄ "	16 ¹⁵ / ₁₆ "	27 ³ / ₈ "	42"	18 ³ / ₁₆ "	26 ³ / ₁₆ "	7 ³ / ₈ "	21"	29"	34 ¹ / ₂ "
L	20 ³ / ₁₆ "	28"	35 ¹ / ₂ "	16 ¹ / ₂ "	5 ³ / ₈ "	18 ¹⁵ / ₁₆ "	29 ⁷ / ₈ "	42"	20 ³ / ₈ "	28 ¹ / ₄ "	15 ¹ / ₈ "	24 ¹ / ₂ "	31 ⁵ / ₈ "	38 ⁷ / ₈ "
Q	14 ¹ / ₄ "	19 ³ / ₄ "	21 ³ / ₈ "	8 ¹ / ₂ "	5 ¹ / ₂ "	10 ³ / ₄ "	22"	42"	14 ¹ / ₂ "	20"	8 ¹ / ₂ "	18 ³ / ₄ "	22"	25 ¹ / ₂ "

Figure 202 (Kuhl Dimensions)

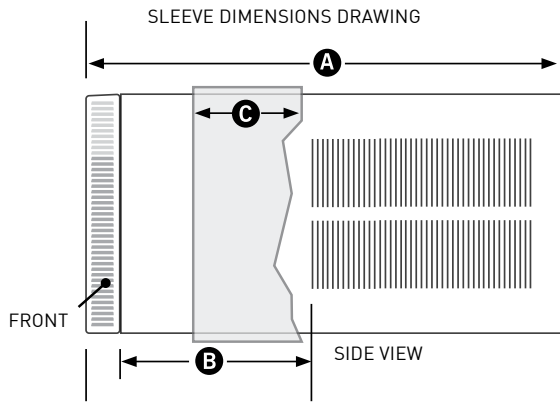

Figure 203 (Kuhl Sleeve Dimensions)

Height	Width	Depth	Height of Front	Width of Front	Depth with Front	Minimum Extension Into Room with Front
15 ³ / ₄ "	26 ¹ / ₂ "	21"	17 ¹ / ₄ "	27 ¹ / ₂ "	23 ¹ / ₄ "	7 ¹ / ₂ "

Figure 204 (Wallmaster Chassis Dimensions)

Height	Width	Depth	Depth with Front	Minimum Extension Outside	Thru-the-wall Finished Hole		
					Height	Width	Max. Depth
16 ³ / ₄ "	27"	16 ³ / ₄ "	24 ¹ / ₄ "	9 ¹ / ₁₆ "	17 ¹ / ₄ "	27 ¹ / ₄ "	15 ⁵ / ₁₆ "

Figure 205 (Wallmaster WSE Sleeve Dimensions)

Sleeve Dimensions			
	Freiedrich WSE Sleeve	Fedders A Sleeve	Fedders B Sleeve*
Height	16 ³ / ₄ "	16 ³ / ₄ "	16 ³ / ₄ "
Width	27"	27"	27"
Depth	16 ³ / ₄ "	16 ³ / ₄ "	19 ³ / ₄ "
*Installation in a Fedders B sleeve requires a baffle adapter kit-BAK			

Figure 206 (Wallmaster WSE Sleeve Dimensions)

Installation Clearances

Improper installation of the Air Conditioner can cause poor performance and premature wear of the unit. Ensure that the unit is installed with proper clearances as described below. Ensure no obstructions, or enclosures are within clearances limits to allow for proper airflow.

Clearances

- Top and Bottom of Unit - One (1) foot
- Sides of Unit - One (1) foot
- Front of Unit - Three (3) feet
- Rear of Unit - Three (3) feet

SPECIFICATIONS

Electrical Data

⚠ WARNING	
	<p>ELECTRIC SHOCK HAZARD Turn off electric power before service or installation.</p> <p>All electrical connections and wiring MUST be installed by a qualified electrician and conform to the National Electrical Code and all local codes which have jurisdiction.</p> <p>Failure to do so can result in personal injury or death.</p>

NOTICE
<p>FIRE HAZARD</p> <p>Not following the above WARNING could result in fire or electrically unsafe conditions which could cause moderate or serious property damage. Read, understand and follow the above warning.</p>





MODEL	CIRCUIT RATING OR TIME DELAY FUSE		REQUIRED WALL RECEPTACLE	
	AMP	VOLT	NEMA NO.	
KCS12, KHS10, KCQ08	15	125	5-15R	
WCT16	15	250	6-15R	
KCM24, KCL28	20	250	6-20R	
KCL36	30	250	6-30R	

Figure 207 (Circuit Breaker / Plug / Receptacle / Cord Rating)

Wire Size - Use ONLY wiring size recommended by the National Electric Code (NEC) for single outlet branch circuit.

Fuse/ Circuit Breaker - Use ONLY the correct HACR type and size fuse/circuit breaker. Read electrical ratings on unit's rating plate. Proper circuit protection is the responsibility of the homeowner.

Grounding - Unit **MUST** be grounded from branch circuit through service cord to unit, or through separate ground wire provided on permanently connected units. Be sure that branch circuit or general purpose outlet is grounded.

Receptacle - The field supplied outlet must match plug on service cord and be within reach of service cord. Do NOT alter the service cord or plug. Do NOT use an extension cord. Refer to the table above for proper receptacle and fuse type.

SPECIFICATIONS

Electrical Data -Power Cord

⚠ WARNING	
	Electrical Shock Hazard Make sure your electrical receptacle has the same configuration as your air conditioner's plug. If different, consult a Licensed Electrician. Do not use plug adapters. Do not use an extension cord. Do not remove ground prong. Always plug into a grounded 3 prong outlet. Failure to follow these instructions can result in death, fire, or electrical shock.

NOTICE
Do not use the LCDI device as an ON/OFF switch. Failure to adhere to this precaution may cause premature equipment malfunction.

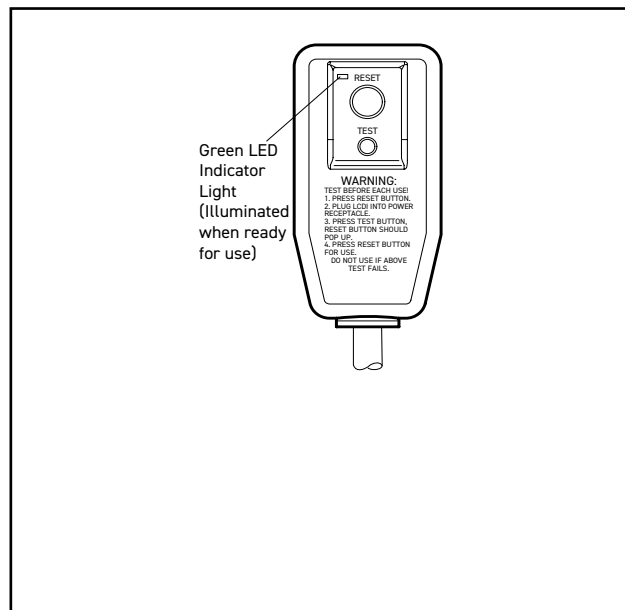

Figure 208 (LCDI Power Cord)

Make sure the wiring is adequate for your unit.

If you have fuses, they should be of the time delay type. Before you install or relocate this unit, be sure that the amperage rating of the circuit breaker or time delay fuse does not exceed the amp rating listed in Table 206.

DO NOT use an extension cord.

The cord provided will carry the proper amount of electrical power to the unit; an extension cord may not.

Make sure that the receptacle is compatible with the air conditioner cord plug provided.

Proper grounding must be maintained at all times. Two prong receptacles must be replaced with a grounded receptacle by a certified electrician.

The grounded receptacle should meet all national and local codes and ordinances. You must use the three prong plug furnished with the air conditioner. Under no circumstances should you remove the ground prong from the plug.

Test the power cord.

All Friedrich room air conditioners are shipped from the factory with a Leakage Current Detection Interrupter (LCDI) equipped power cord. The LCDI device on the end of the cord meets the UL and NEC requirements for cord connected air conditioners.

To test your power supply cord:

1. Plug power supply cord into a grounded 3 prong outlet.
2. Press RESET (see Figure 207).
3. Press TEST, listen for click; the RESET button trips and pops out.
4. Press and release RESET (Listen for click; RESET button latches and remains in). Check that the green LED light is on. The power cord is ready. for use.

Once plugged in, the unit will operate normally without the need to reset the LCDI device. If the LCDI device fails to trip when tested or if the power supply cord is damaged, it must be replaced with a new power supply cord from the manufacturer.

OPERATION

Airflow Selection and Adjustment -Kuhl

The airflow path may be adjusted to distribute air independently from the left or right side of the discharge opening. Each of the banks of louvers can be directed left, right, up, or down in order to achieve the most optimum airflow positioning.

To adjust airflow direction, grab the lever in the center of the louver bank and move it in the direction that you would like the air to be directed. Please note that it is normal that airflow may be stronger out of one side of the louvers than the other.

Fresh air and exhaust control

Your air conditioner has the ability to bring fresh air into the room or exhaust stale air out of the room. The control slide is found on the upper part of the unit (see Figure 301).

TO BRING IN FRESH AIR – Move the lever to the Fresh Air  position which allows outside air to enter the room. This is useful in fall and spring as a means of bringing in fresh outside air when using FAN ONLY. It can also be used in the summer with the compressor in the Cooling Mode if you wish.

TO EXHAUST INDOOR AIR – Move the lever to the Exhaust  position. This will allow stale air to be expelled to the outside of the dwelling. This is especially handy in the spring or fall when indoor air tends to get stale, or after a social gathering involving smokers, or to remove cooking odors.

BEST PERFORMANCE – Move the lever to the **Re-Circulate Position**.  This is the most efficient mode for cooling and heating. In this mode the unit will not bring air in or exhaust air.

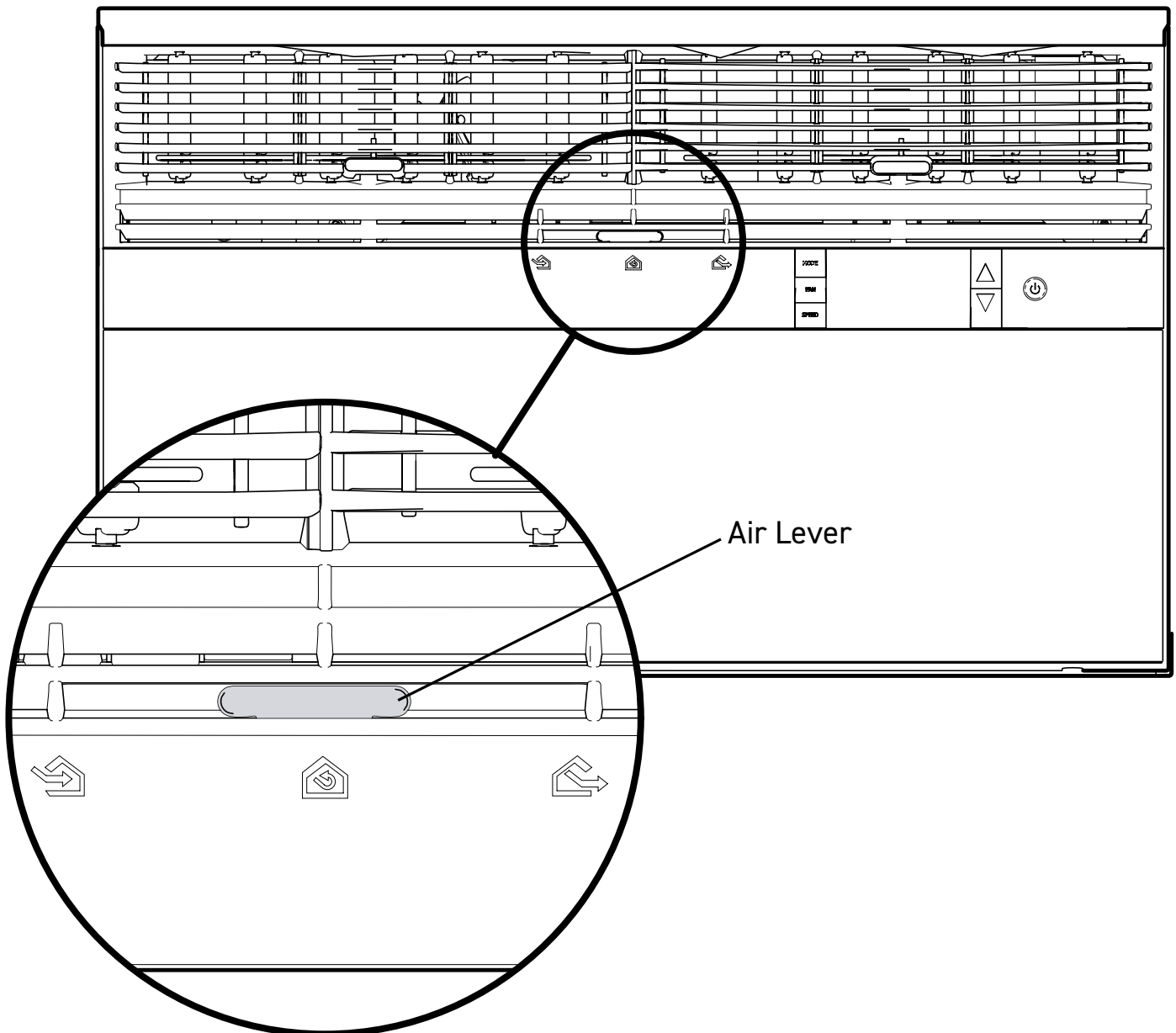

Figure 301a (Airflow Selection And Adjustment)

OPERATION

Airflow Selection and Adjustment -Kuhl Q

The airflow path may be adjusted to distribute air independently from the left or right side of the discharge opening. Each of the banks of louvers can be directed left, right, up, or down in order to achieve the most optimum airflow positioning.

To adjust airflow direction, grab the lever in the center of the louver bank and move it in the direction that you would like the air to be directed. Please note that it is normal that airflow may be stronger out of one side of the louvers than the other.

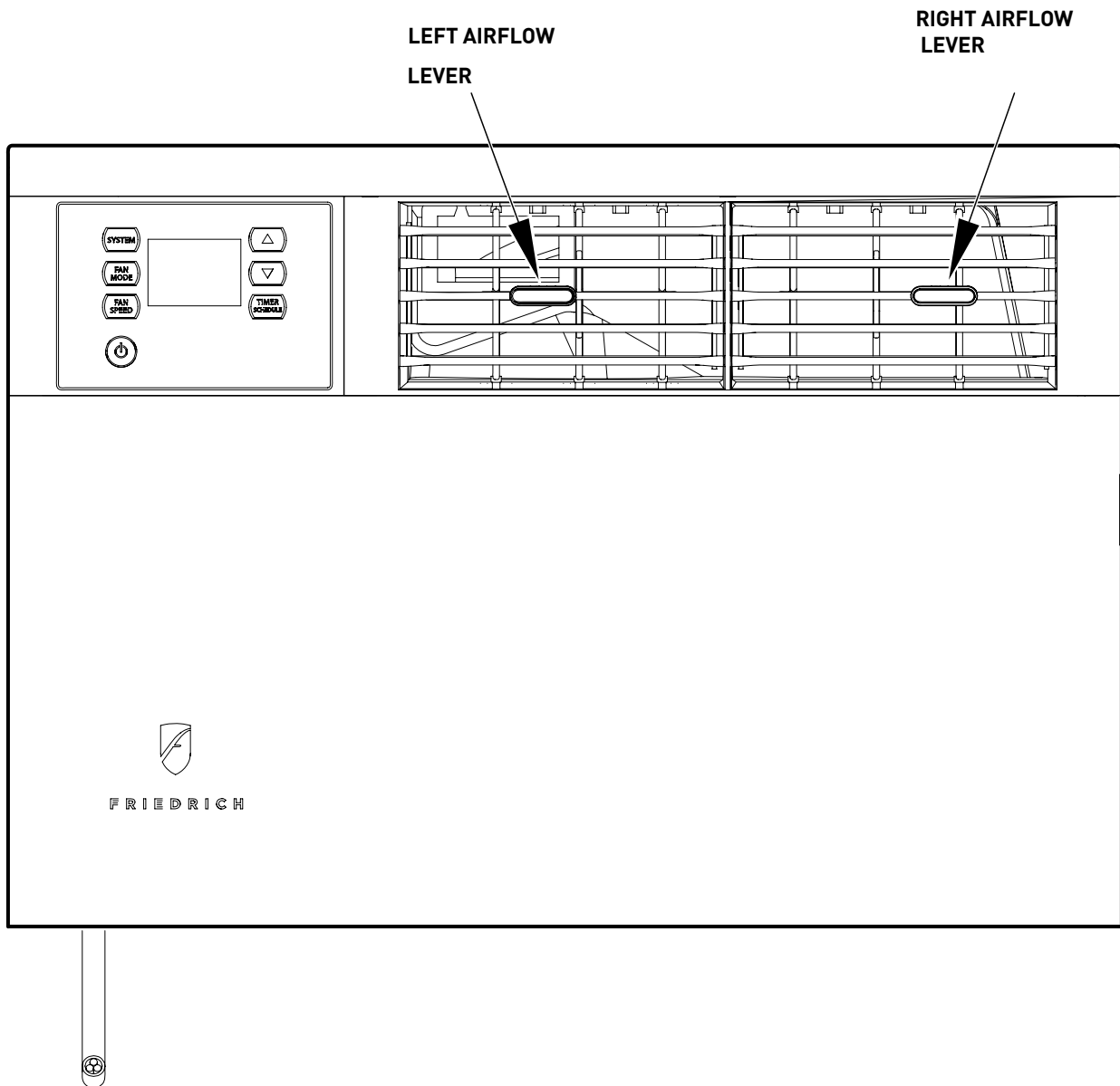

Figure 301b (Airflow Adjustment)

OPERATION

Airflow Selection and Adjustment -Wallmaster

The airflow path may be adjusted to distribute air independently from the left or right side of the discharge opening. Each of the banks of louvers can be directed left, right, up, or down in order to achieve the most optimum airflow positioning.

To adjust airflow direction left or right, grab the lever in the center of the louver bank and move it in the direction that you would like the air to be directed. To adjust the airflow up or down, rotate the entire vent to the desired position. Please note that it is normal that airflow may be stronger out of one side of the louvers than the other.

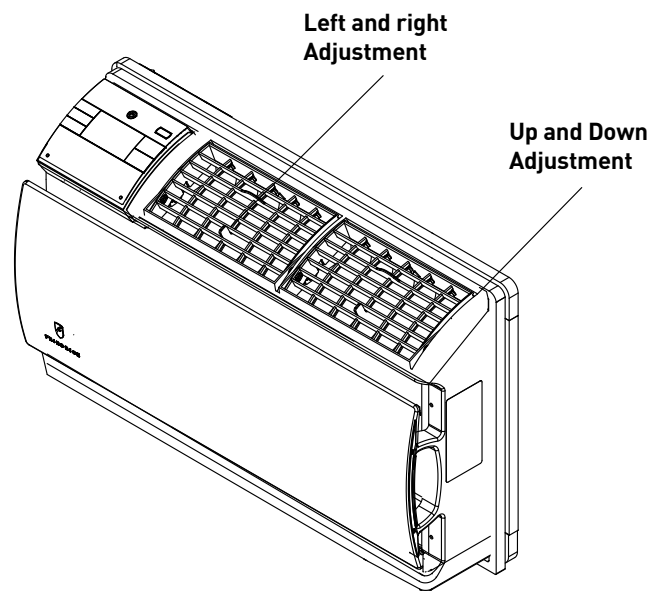

Figure 302 (Airflow Selection And Adjustment)

OPERATION

User Interface-Kuhl

All of the control panel function buttons and mode icons can be viewed in Figures 302 and 303.

Power On – Press the button to turn on the air conditioner. The power button illuminates to indicate that the power is on. The backlight on the power switch will automatically turn off after 20 seconds of inactivity. The remote control can also be used to turn power ON / OFF (see Remote Control).

Display – The display is a high efficiency LCD with a built-in backlight. After 20 seconds of inactivity, the display switches off. Touching any button automatically changes the display to full brightness.

There are three control push buttons on each side of the display.

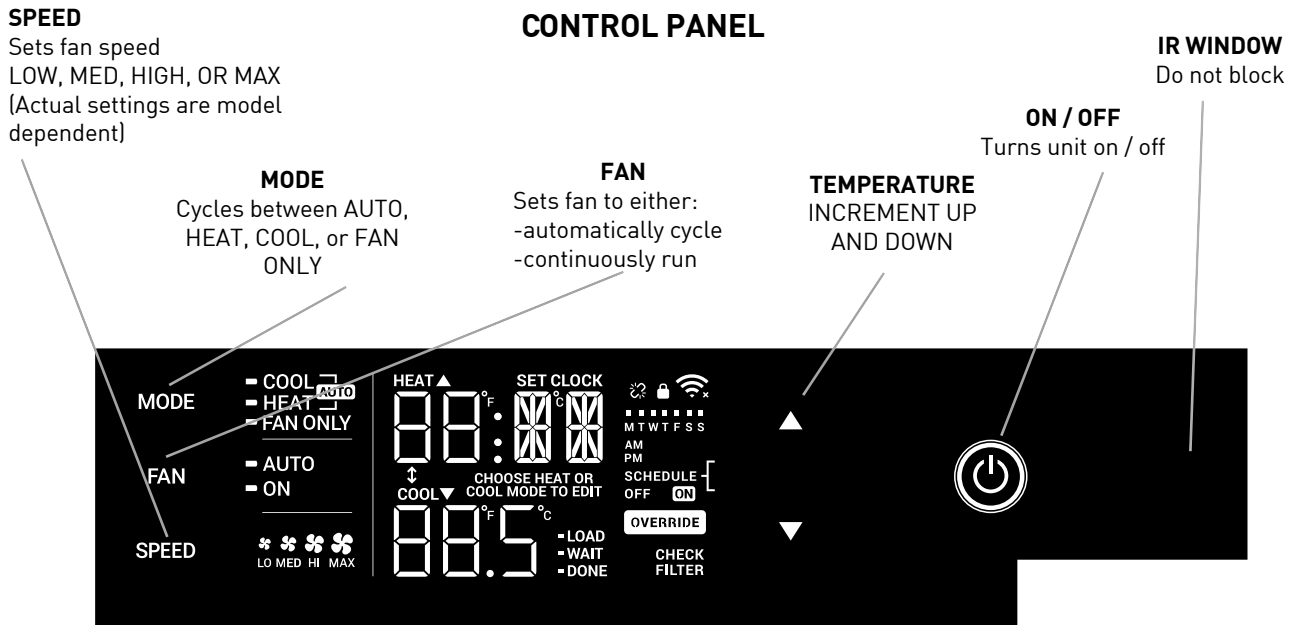

Figure 303

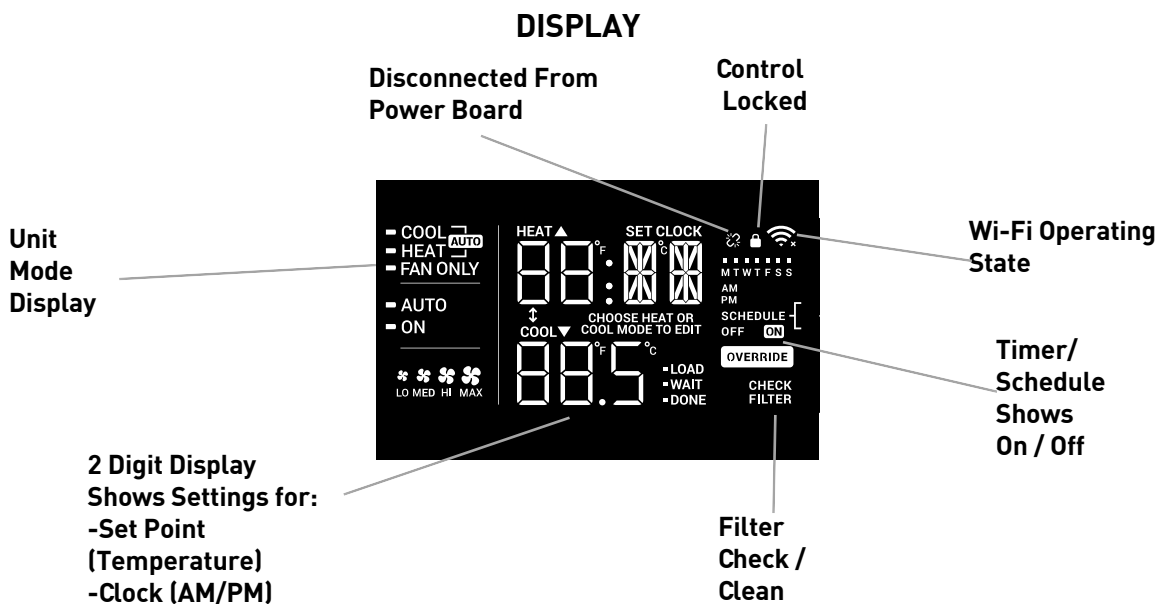

Figure 304

OPERATION

User Interface - Kuhl Q

All of the control panel function buttons and mode icons can be viewed in Figure 305.

Power On – Press the button to turn on the air conditioner. The power button illuminates to indicate that the power is on. The backlight on the power switch will automatically turn off after 20 seconds of inactivity. The remote control can also be used to turn power ON / OFF (see Remote Control).

Display – The display is a high efficiency LCD with a built-in backlight. After 20 seconds of inactivity, the display switches off. Touching any button automatically changes the display to full brightness.

There are three control push buttons on each side of the display.

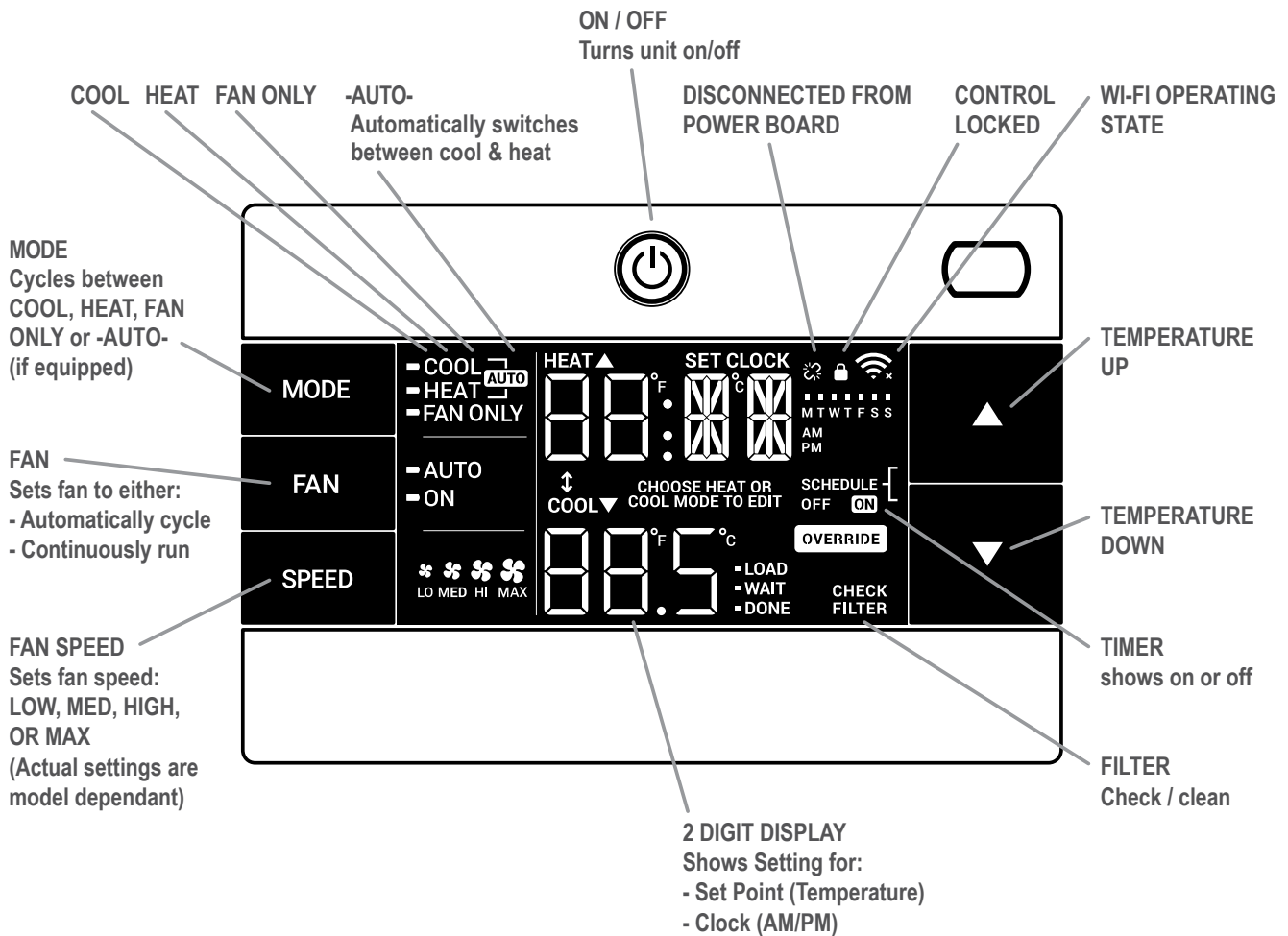

Figure 305 (Control Panel and Display)

OPERATION

User Interface- Wallmaster

All of the control panel function buttons and mode icons can be viewed in Figures 307.

Power On – Press the button to turn on the air conditioner. The power button illuminates to indicate that the power is on. The backlight on the power switch will automatically turn off after 20 seconds of inactivity. The remote control can also be used to turn power ON / OFF (see Remote Control).

Display – The display is a high efficiency LCD with a built-in backlight. After 20 seconds of inactivity, the display switches off. Touching any button automatically changes the display to full brightness. There are three control push buttons on each side of the display.

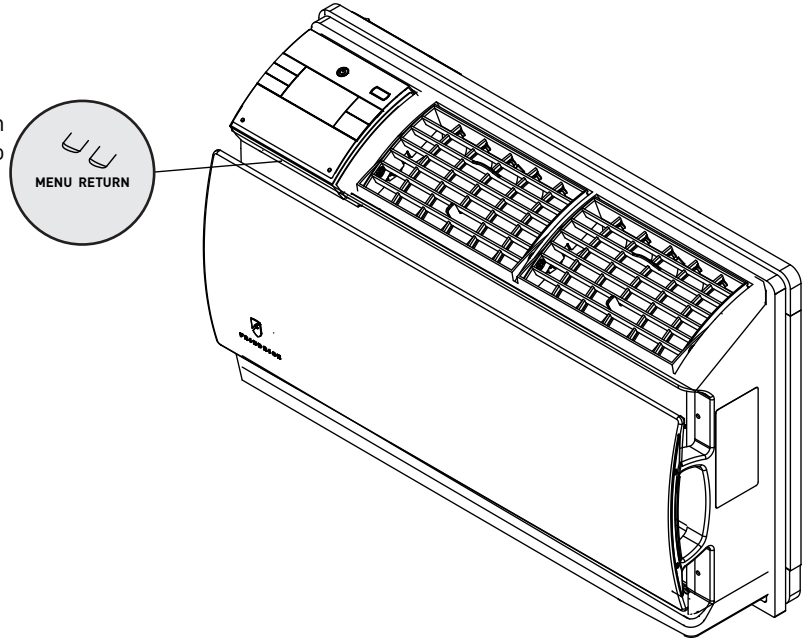

Figure 306 (Wallmaster Menu Buttons)

CONTROL PANEL AND DISPLAY

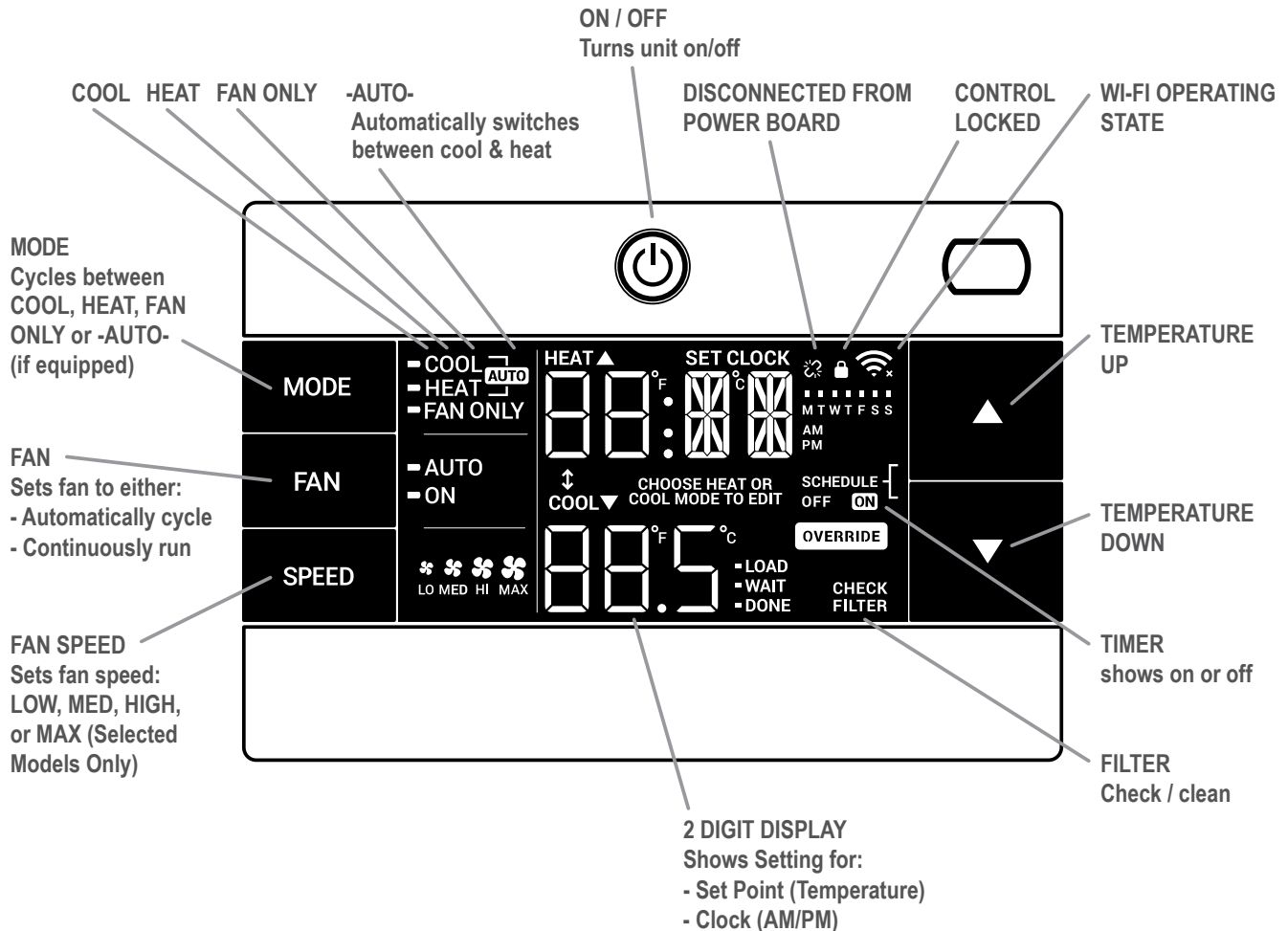

Figure 307 (Display Panel)

OPERATION

User Interface - All Models

Accessing Sub-Menus

The MENU button accesses the sub-menu.

Press the Menu Button to enter the Menu. See Figure 308.

The arrow buttons navigate the 6 menu options. See Figure 309

- LIM
- LOCK
- TM
- CnCT
- F-C
- diAG

The return button exits the menu. See Figure 310.

Figure 308

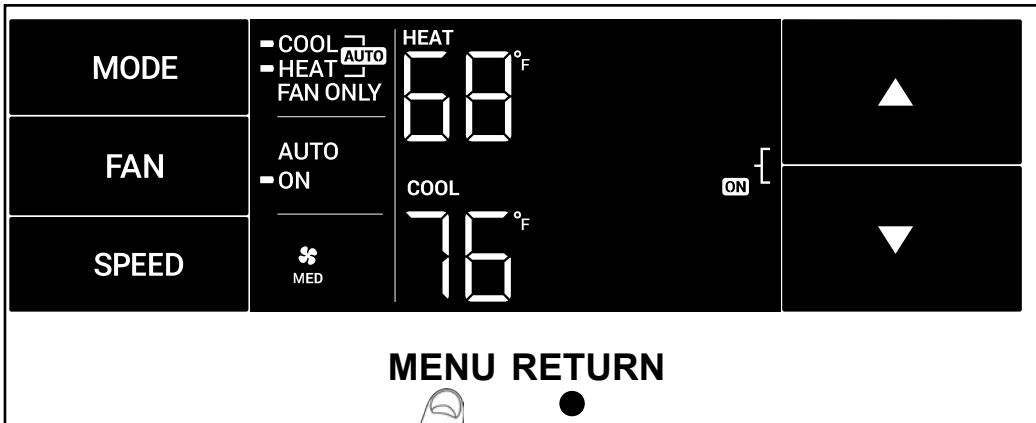

Figure 309

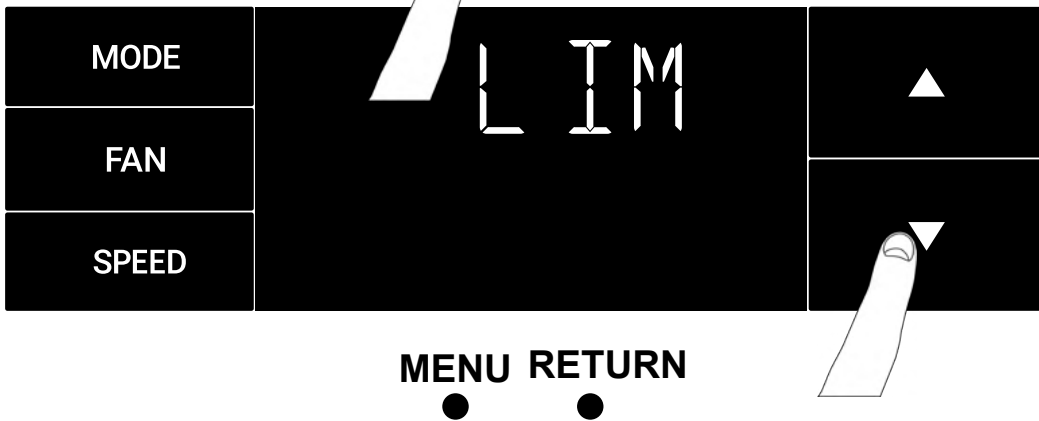
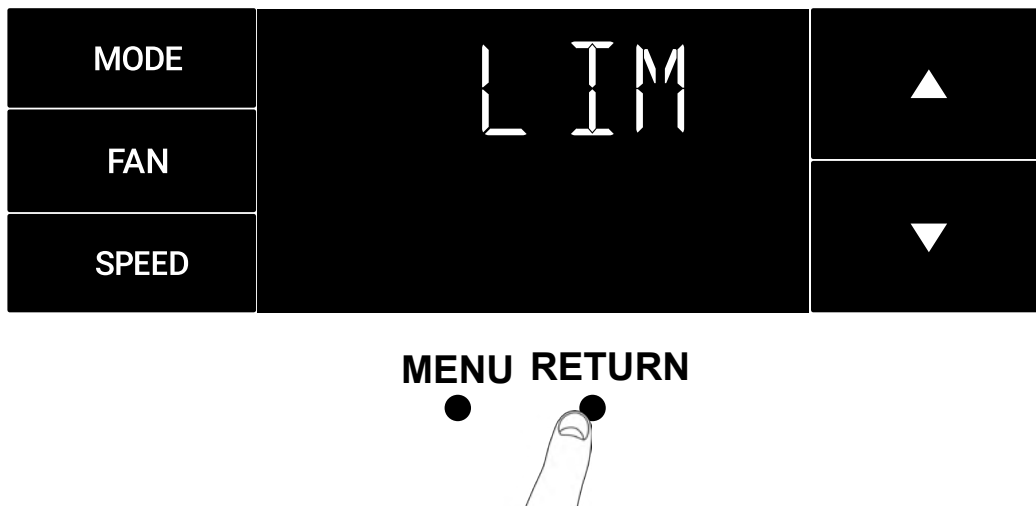

Figure 310



OPERATION

User Interface - All Models

Navigating Inside the Sub-Menus

The MENU button moves you forward through the sub-menu. See Figure 311

The return button moves you backward once inside the LIM and TM menus. See Figure 312.

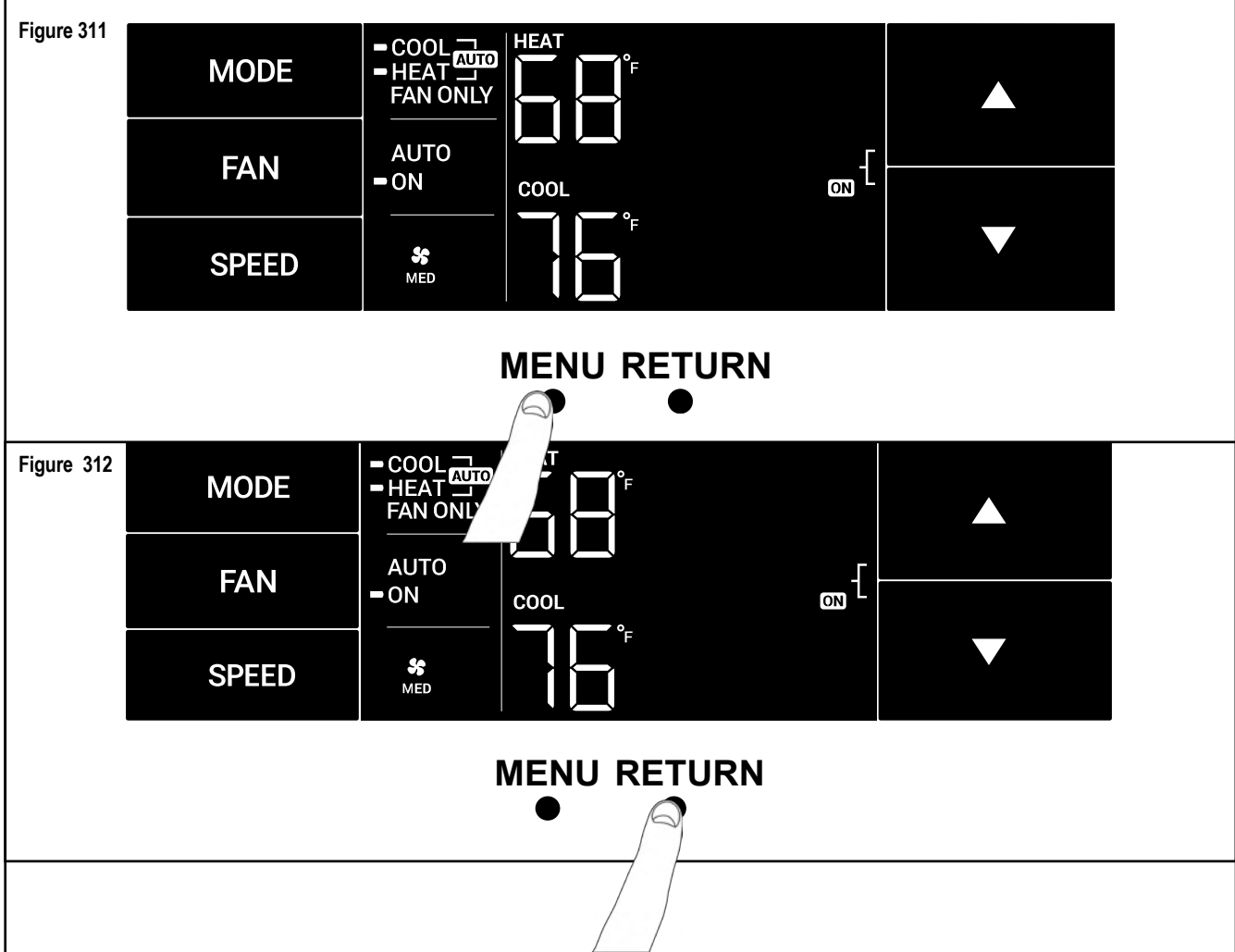

OPERATION

User Interface - All Models The LIM Menu (LIMIT)

This is the limit menu. See Figure 313.

Upon entering the menu, the first option will be to set the lower set-point limit using the arrow buttons. See Figure 314.

Then you can set the higher set-point limit using the arrow buttons. See Figure 315.

Pressing the menu button completes the limit setting. See Figure 316.

Figure 313



MENU RETURN



Figure 314

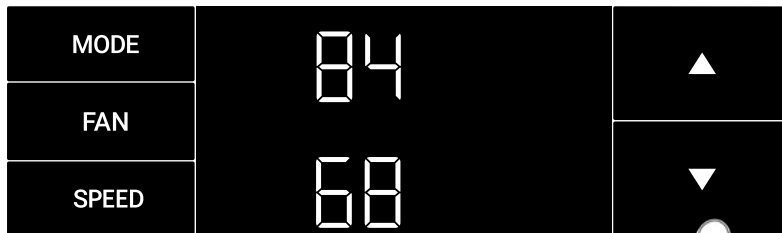

MENU RETURN



Figure 315

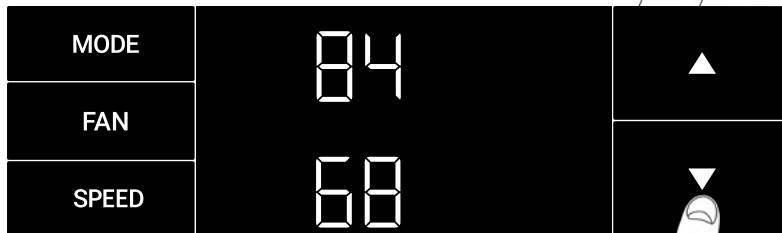

MENU RETURN



Figure 316

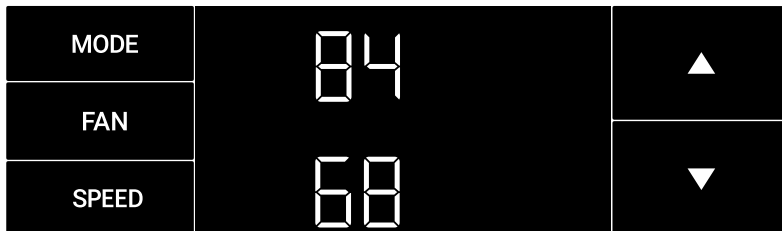

MENU RETURN

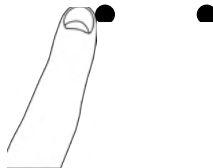

OPERATION

User Interface - All Models The TM Menu (Timer)

This is the TM menu used to set a timer. See Figure 317.

In the menu, you set the current time using the arrow buttons. See Figure 318. (Note: These two “set clock” steps will be skipped if the unit is already connected to Wi-Fi.)

First, set the hour.

Using the MENU button, you switch to the minutes and complete setting the time. See Figure 319.

You select your mode. Either cool, heat, or auto. Toggle these using the mode button. See Figure 320. (Note: cooling-only models skip this step.)

The process is the same for all three modes. Auto mode will be shown as the example.

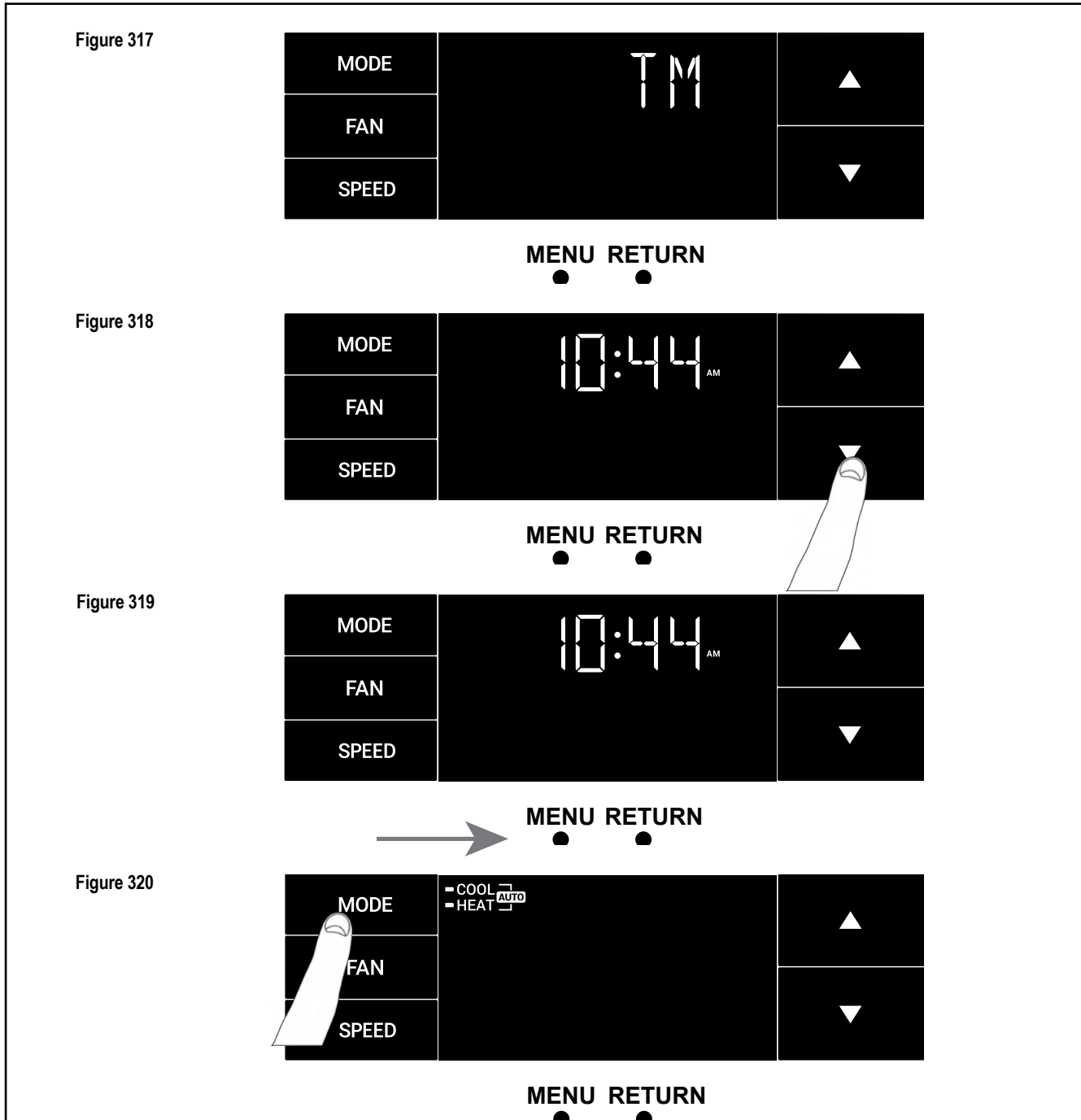

OPERATION

User Interface - All Models

The TM Menu (Timer) continued

Auto mode selected. See Figure 321.

Set the cool set-point for your first timer period using the arrow buttons. The cooling mode timer only sets the cool set-point. See Figure 322.

Next, set the heat set-point for your first timer period. The heating mode timer only sets the heat set-point. See Figure 323.

Note: The auto mode timer sets both the cool and heat set-point.

Set the time to start the first timer period. See Figure 324.

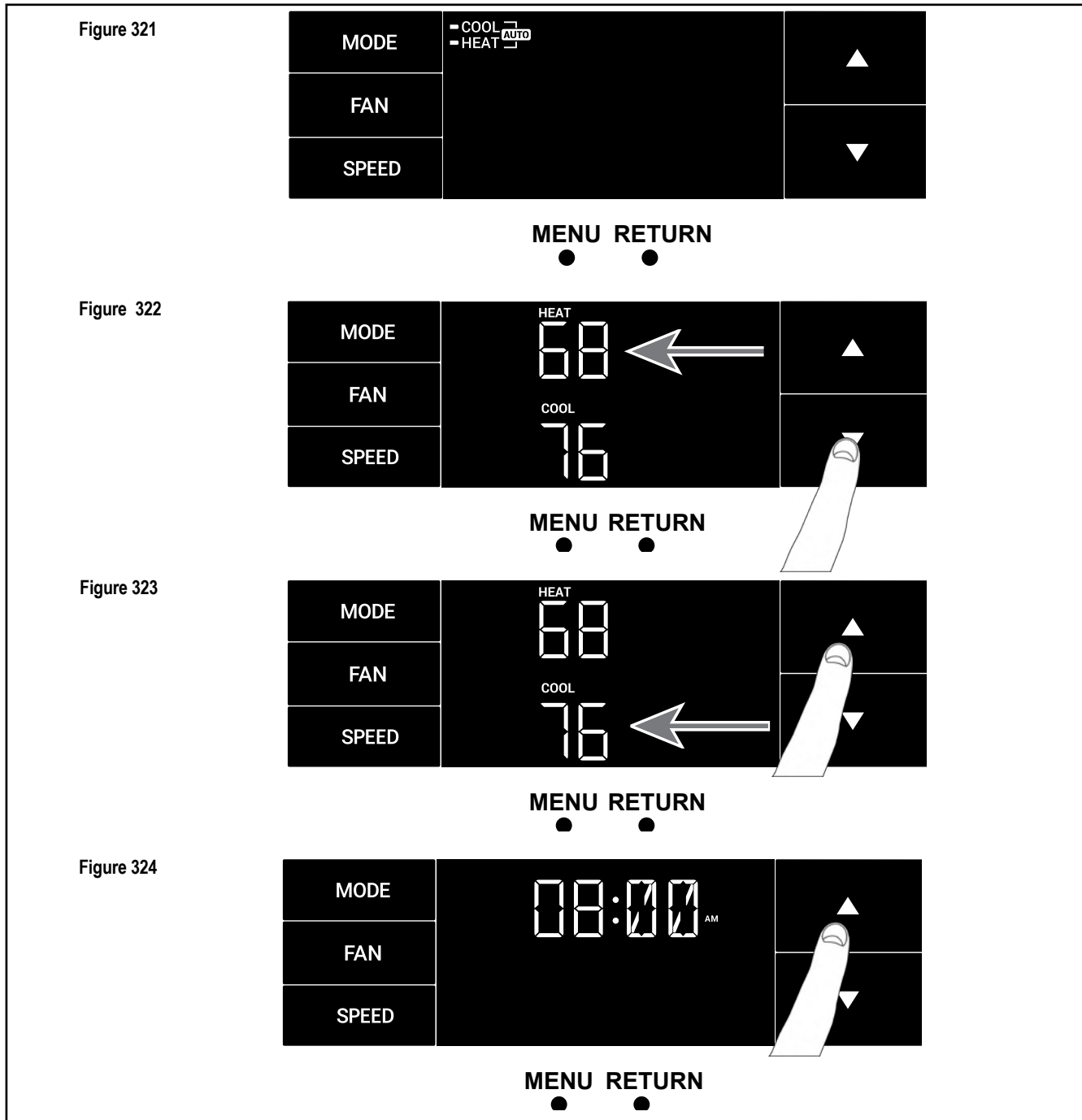

OPERATION

User Interface - All Models

The TM Menu (Timer) continued

Set the cool set-point for the second scheduled timer. See Figure 325.

Set the heat set-point for the second timer.

Set the time to start the second timer period. See Figure 326.

Press the MENU button to complete the time timer setup.
See Figure 327

Figure 325

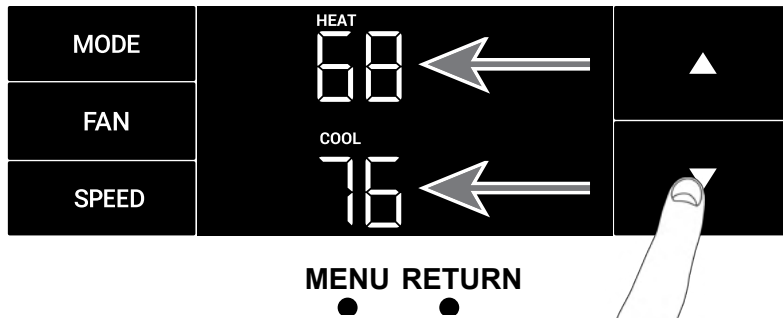
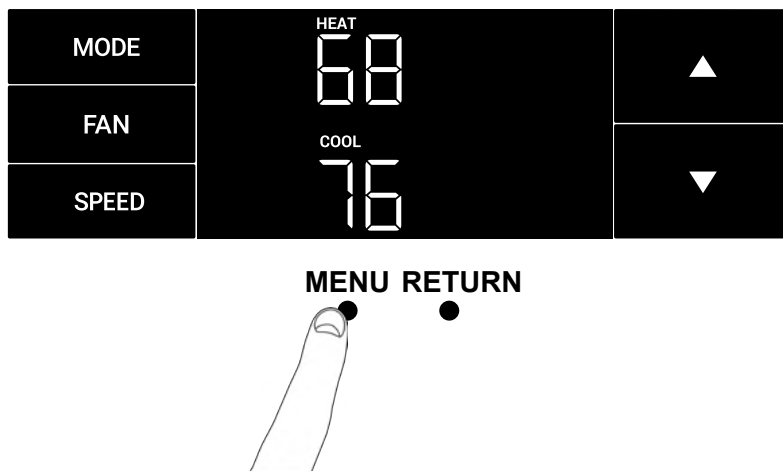

Figure 326



Figure 327



OPERATION

User Interface - All Models

The F-C Menu (Fahrenheit/Celsius)

This menu is used to toggle between Fahrenheit and Celsius. See Figure 328.

Using the arrow buttons on the right side switches it from Fahrenheit to Celsius. See Figures 329 and 330.

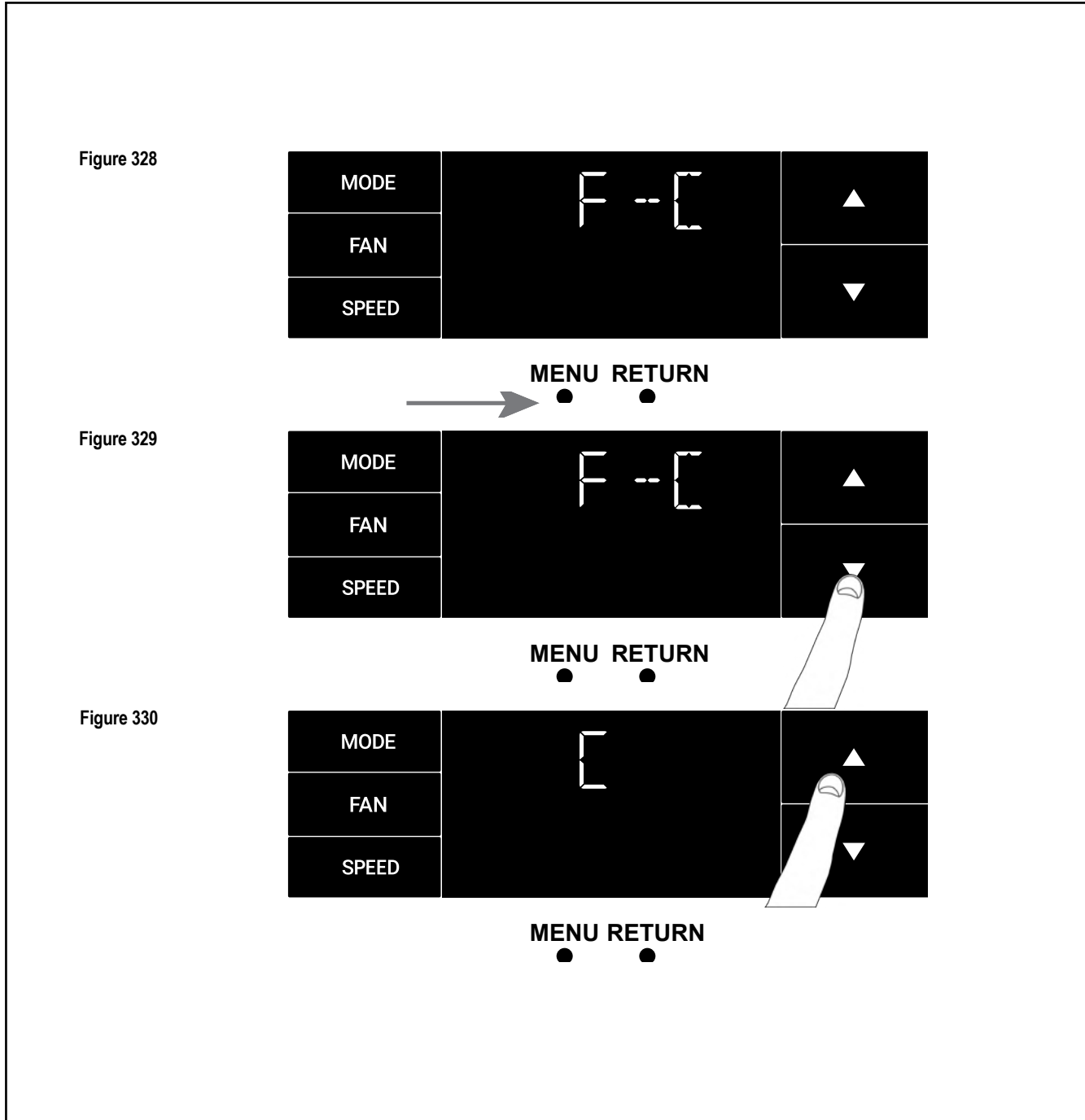

OPERATION

User Interface - All Models The Lock Menu

This menu is used to lock the settings with a four(4) digit passcode.

This is the Lock Menu. See Figure 331.

The menu lock default is off. Use the arrows to toggle between off and on. See Figure 332.

This is LOCK on. See Figure 333.

Set the first digit of the password using the arrow buttons. Use the menu button to proceed to the next digit. See Figure 334.

Repeat the previous step for the remaining three(3) digits.

Press the menu button to complete the lock setting process..

NOTICE

Be Sure to write down your passcode if you activate this feature.

— — — —

Please contact Technical Support if you have lost your lock code.

1-800-541-6645

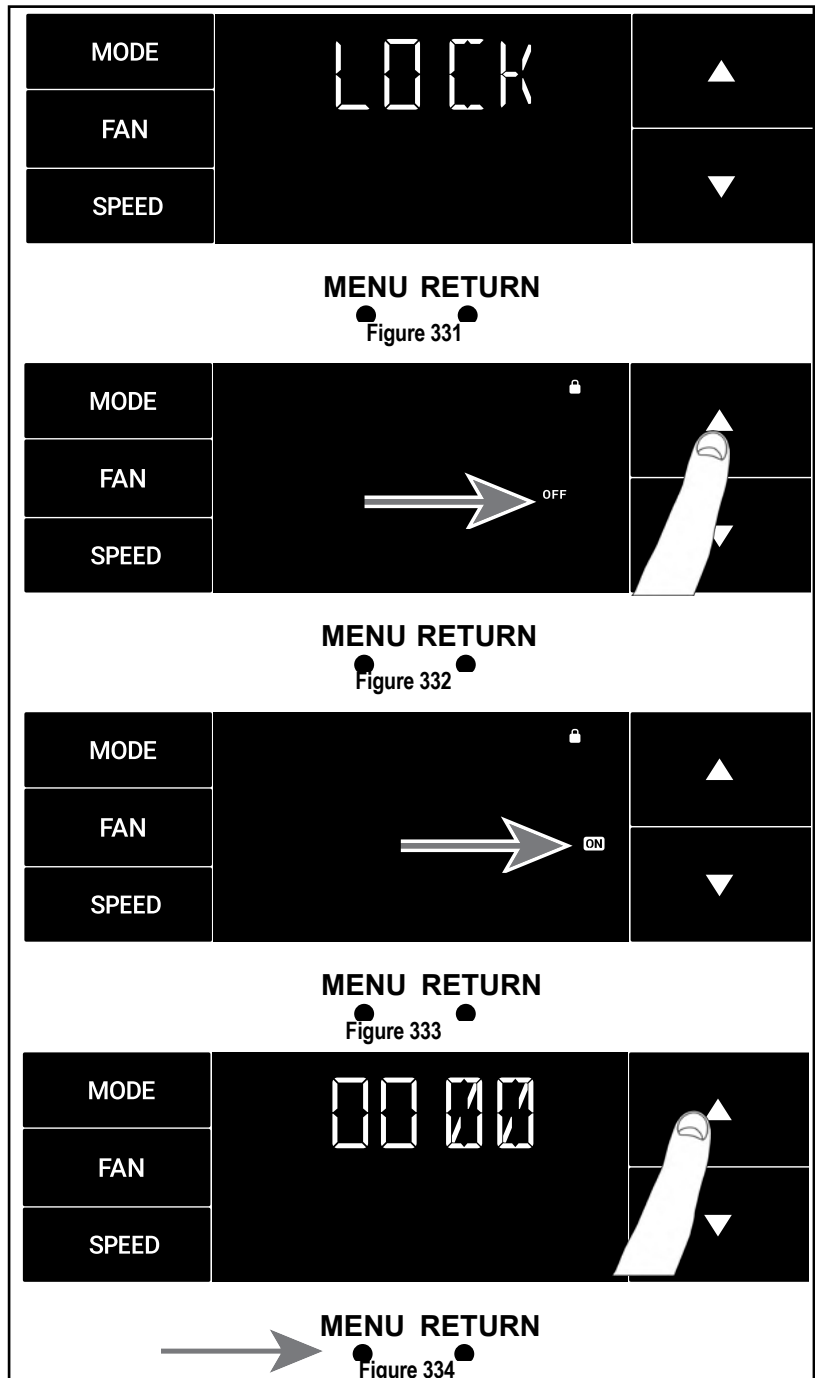

OPERATION

User Interface - All Models The Lock Menu continued

The ON on the right side of the display shows the lock function is active. To go back into the menu, select the menu button again. See Figure 335.

Enter the password in the same manner it was created. See Figure 336.

Entering the correct password will give the user access to all of the sub-menus. See Figure 337.

Accessing the lock menu will allow you to toggle lock OFF if needed. See Figure 338.

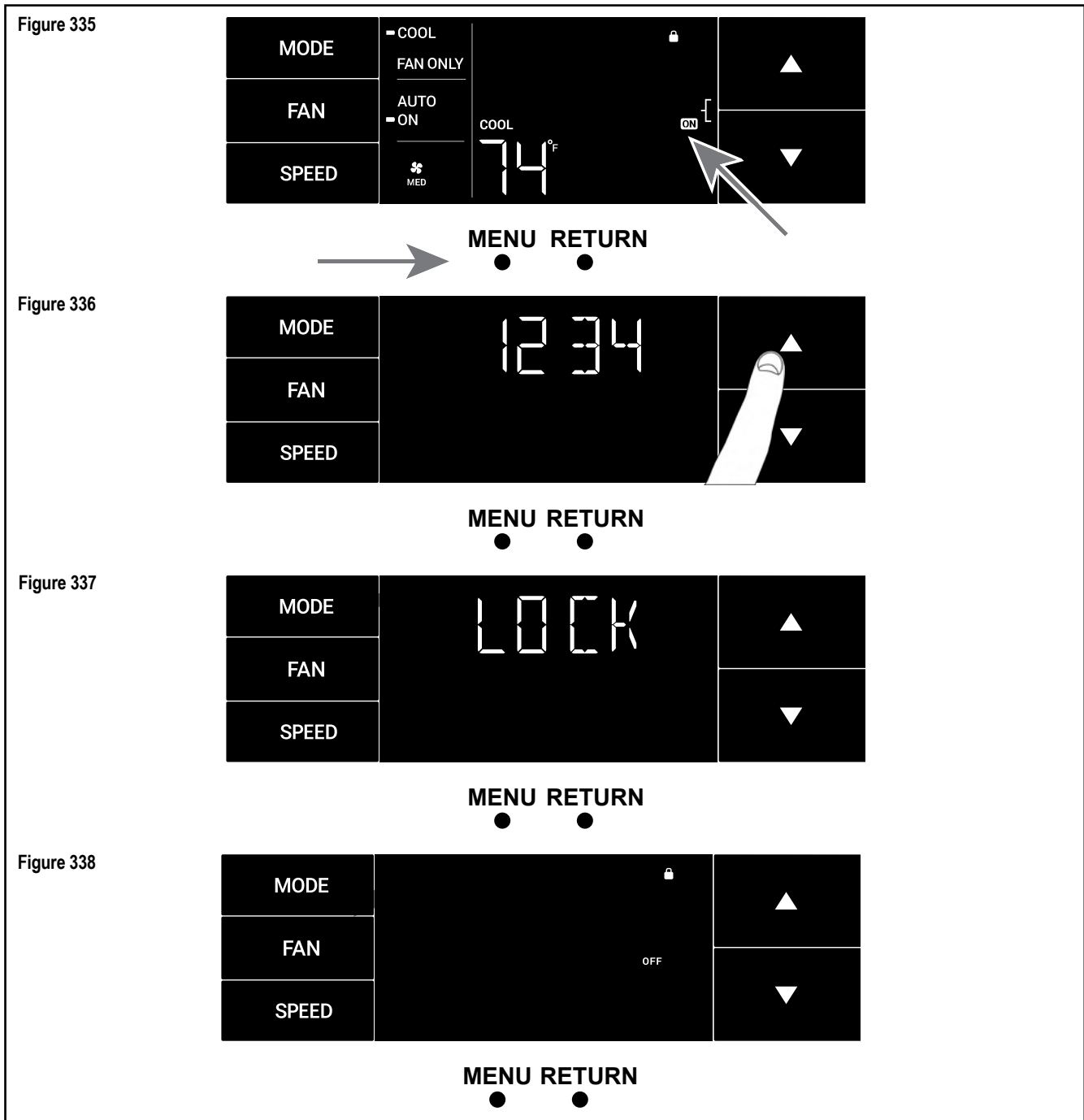

OPERATION

User Interface The diAG Menu

This menu is used to access the diagnostic codes. See Figure 339.

Selecting this sub-menu shows the E that represents "Error." See Figure 340.

Toggle through the error codes using the arrow keys. See Figure 341.

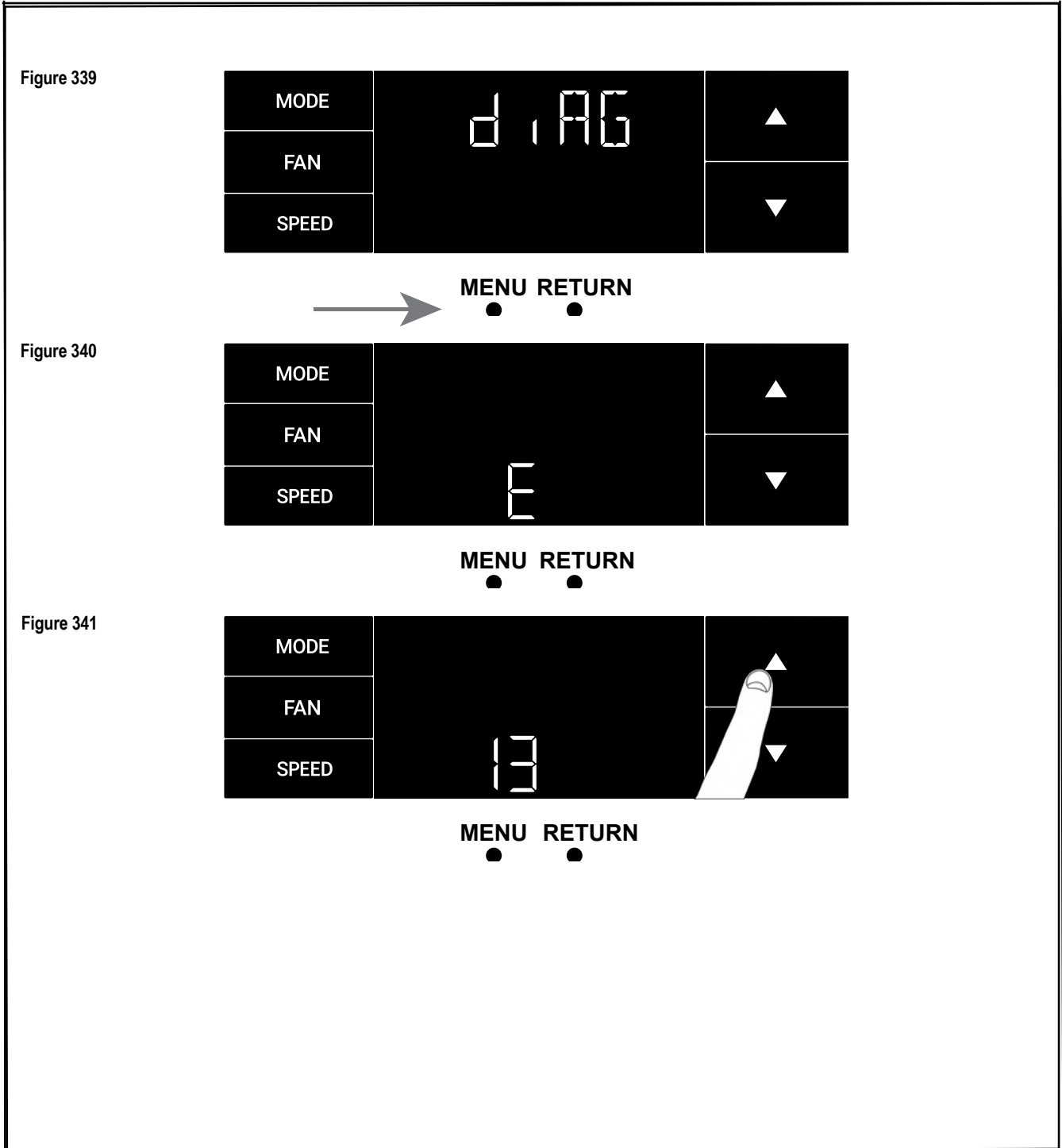

OPERATION

User Interface

The CnCT Menu (WiFi Connection)

This menu is used to turn on Wi-Fi connection.

This is the CnCT menu. Pressing the menu button will activate Wi-Fi. See Figure 342.

To setup WiFi, refer to Wi-Fi setup instructions.

The Wi-Fi symbol in the top right corner of the display shows Wi-Fi connection is on. See Figure 343.

Figure 342



MENU RETURN



Figure 343

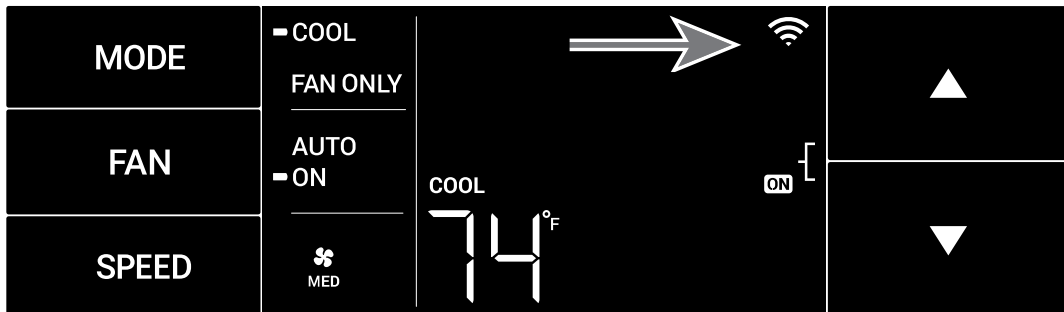

MENU RETURN



OPERATION

Control Panel

SYSTEM - The MODE button allows you to sequentially select up to four modes of operation:

- AUTO Available on select models
- COOL
- HEAT Available on select models
- FAN ONLY

AUTO FAN (No Cooling Demand)

When in AUTO mode, the fan only operates when the system has a demand to cool or heat the room.

In the ON fan mode, the fan operates all the time. The system periodically cools or heats the fan's airflow but the flow of air does not stop.

UP and DOWN Arrows - Pressing either an UP or DOWN button changes the system's set-point (desired room temperature). These buttons are also used to make system parameter changes later in this manual.

One press equals 1 degree of change in Fahrenheit mode. One press equals 0.5 degree change in Celsius mode.

TIMER

The timer can be engaged or disengaged from the control panel. This is done by pressing or holding the UP and DOWN arrows simultaneously for three seconds.

OTHER FUNCTIONS

°F - °C Select

To switch from degrees Fahrenheit (F) to Celsius (C), press the MENU button and enter the F-C sub-menu.

FAN SPEED - Depending on your model, the FAN SPEED button allows you to toggle between three or four modes of operation: LOW, MEDIUM, HIGH and MAX.

Alerts

When the filter needs to be cleaned or replaced, the CHECK FILTER icon displays. Refer to Routine Maintenance for filter maintenance requirements.

The alert can be dismissed by pressing the FAN and SPEED buttons for 3 seconds.

Lock Control Panel

To lock/unlock the front panel controls, navigate to the "LOCK" sub-menu found after clicking the MENU button. The lock requires a four digit pass code to lock/unlock the unit. This pass code will be required to enter the menu to unlock the unit. Be sure to write the password down and retain for future use. The LOCK icon illuminates to indicate the locked status.

The LOCK icon disappears to indicate unlocked status.

External Control Status

The Wi-Fi icon illuminates to indicate that the system is receiving a Wi-Fi connection. The Wi-Fi icon also provides information about the signal strength.



Advanced Functions

The functions mentioned in the following section may or may not be available depending on the air conditioner model.

Modify the TIMER Function



Navigate to the TIME menu to set the timer.

OPERATION

Remote Control

Remote Control - Refer to Figure 344 during operation description.

Getting Started - Install two (2) AAA batteries in the battery compartment located on the back of the unit.

Operation - The remote control should be within 25 feet of the air conditioner for operation (refer to Figure 345 for effectiveness). Press the power button to turn the remote on. The remote will automatically power off after 15 seconds if the buttons are not being pressed. The remote must be on to control the unit.

POWER Button - Turns remote and unit on and off.

MODE Button - Allows the user to sequentially select the following: AUTO, COOL, HEAT, and FAN ONLY operations. When the button is pressed, the display indicates which mode has been selected via a display message. Note that when the heating function is not available, the system will automatically skip the HEAT mode.

FAN Button - Selects between automatic (AUTO FAN) or CONTINUOUS operation. In the AUTO FAN mode, the fan only turns on and off when the compressor operates or the heat function is enabled.

NOTE: AUTO FAN is not available in the FAN ONLY Mode, the display indicates CONTINUOUS. In the CONTINUOUS mode, fan speed is determined by your selection on the FAN SPEED button.

SPEED Button - Used to sequentially select new fan speed, plus AUTO operation. When the FAN SPEED button is pressed, the fan speed icon (triangle) changes to indicate the new speed level. Fan speed automatically varies depending on the set temperature on the control panel and the actual room temperature. For example, if there is a big difference between your set temperature and the actual room temperature, the system fan speed increases to HIGH. It remains at this speed until the room temperature matches the set temperature.

UP and DOWN Arrows - Pressing either the UP or DOWN button changes the desired room temperature. The factory preset lower and upper limits are 60°F (16°C) and 99°F (37°C). These buttons are also used to navigate between function options when using the User Menu or Maintenance Mode.

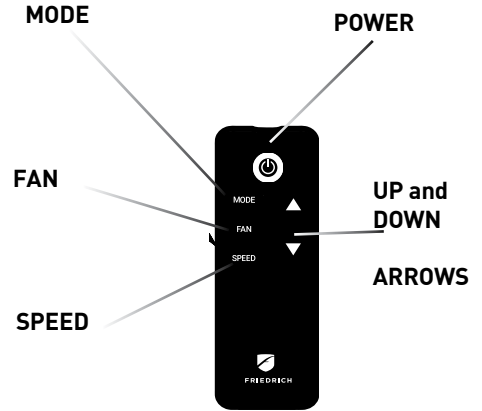

Figure 344 (Remote Control)

Remote Effectiveness

Handheld Remote - Has an operating range of up to 25 ft. The infrared remote control signal must have a clear path to transmit the command to the air conditioning unit. The remote signal has some ability to “bounce” off of walls and furniture similar to a television remote control. The diagram below shows the typical operating range of the control in a standard room with 8 ft high ceilings.

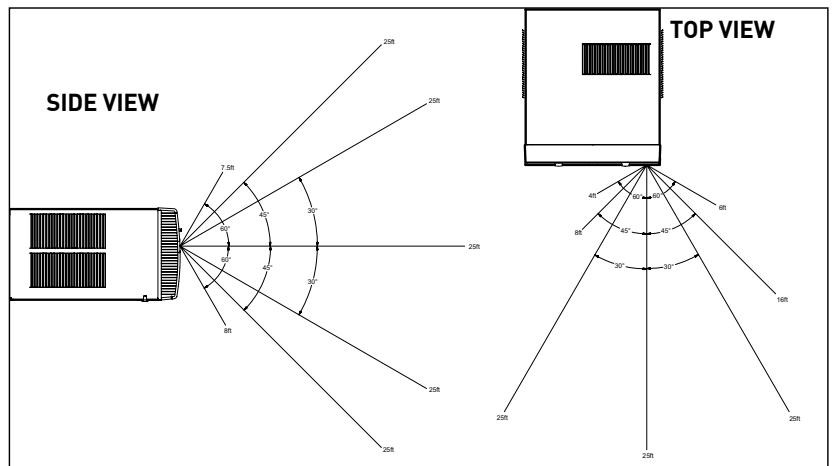

Figure 345 (Remote Control Effectiveness)

OPERATION

Unit Cooling

Your air conditioner is designed to cool in warm weather when the outside temperature is above 60°F (15.6°C) and below 115°F (46.1°C), so it won't cool a room if it is already cool outside. If you want to cool a room in the spring or fall, select the FAN ONLY mode and set the Fresh Air/Exhaust air control to Fresh Air. This will bring in a supply of cooler outside air.

Condensation is normal

Air conditioners actually pump the heat and humidity from your room to the outside. Humidity becomes water, and your air conditioner will use most of the water to keep the outside coil cool. If there is excessive humidity, there may be excess water that will drip outside. This is normal operation.

Frosting

This usually occurs because of insufficient airflow across the coils, a dirty filter, cool damp weather, or all these. Set the SYSTEM mode to FAN ONLY and the frost will disappear. Setting the thermostat a little warmer will probably prevent the frosting from recurring.

Noises

Friedrich units are designed to operate as quietly as possible. An air conditioner mounted in a wall is quieter than one mounted in a window. It is important to ensure that the chassis seal gasket is properly installed (refer to SPECIFICATIONS FIGURE 205).

Heat pumps operate differently

If your unit is a heat pump model (KHS10B10A), there are some things that you will want to be aware of. Some functions of a heat pump differ from your unit when it is used for heating:

1. It is normal for ice to form on the outdoor coil of the heat pump. Moisture in the outside air, passing over the coil when very cold, will form ice.
2. If the outdoor temperature drops below 37°F (3°C), your heat pump will automatically turn on the electric resistance heat. When the temperature rises to 40°F (4°C), the compressor will resume the heat pump operation. If your unit is a 115 volt model (KHS10B10A), it is designed for use in warmer climates and does not have an electrical heat feature, and will not provide adequate heat below 37°F (2.8°C).

Compressor and Reversing Valve Control

Active Mode	Compressor	Reversing Valve
Cooling	On	De-Energized
Heat - Pump	On	Energized
Heat - Electric	Off	
Fan Only	Off	

Figure 346 (Compressor Operation)

Reversing Valve

The reversing valve stays in the last state until a call for heat or cooling .

The reversing valve only changes when required to provide cooling or heat pump. Leave the reversing valve in it's last state until it's required to change.

OPERATION

Unit Cooling Mode

Once the indoor ambient temperature rises past the cool demand threshold (Cool Set Point + 1.5 °F) (see figure below), and the compressor is not locked out, the cooling cycle begins. As shown in the figure below, the fan is started 5 seconds prior to the compressor. Once the indoor ambient temperature has been lowered to the cool set point (Cool Set Point minus .25 °F), the cooling cycle starts to terminate by shutting off the compressor. After a 30 seconds delay, the fan is shut off. (See figure below for graphic details)

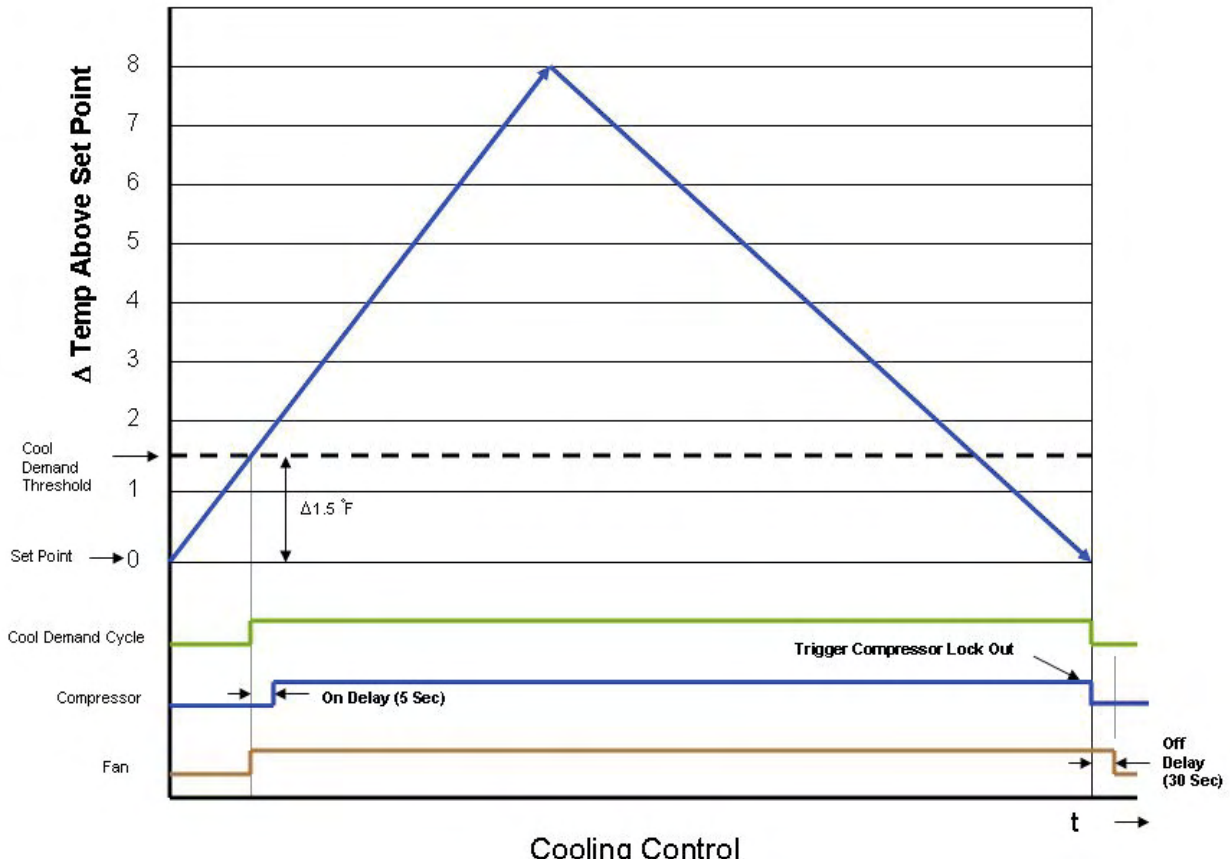

Figure 347 (Cooling Control)

OPERATION

Unit Heat Control Operation - Heat Pump Only Unit

Once the ambient temperature falls below the Heating Demand Threshold (1.5 °F Below the Heat Set Point Temperature), the heating cycle begins. The fan is turned on 5 seconds before. Once the ambient temperature has been raised to the Heat Satisfied Point (Set point + .25 °F), the compressor is turned off. The fan is turned off 15 seconds later. The figure below illustrates the basic heat pump operation.

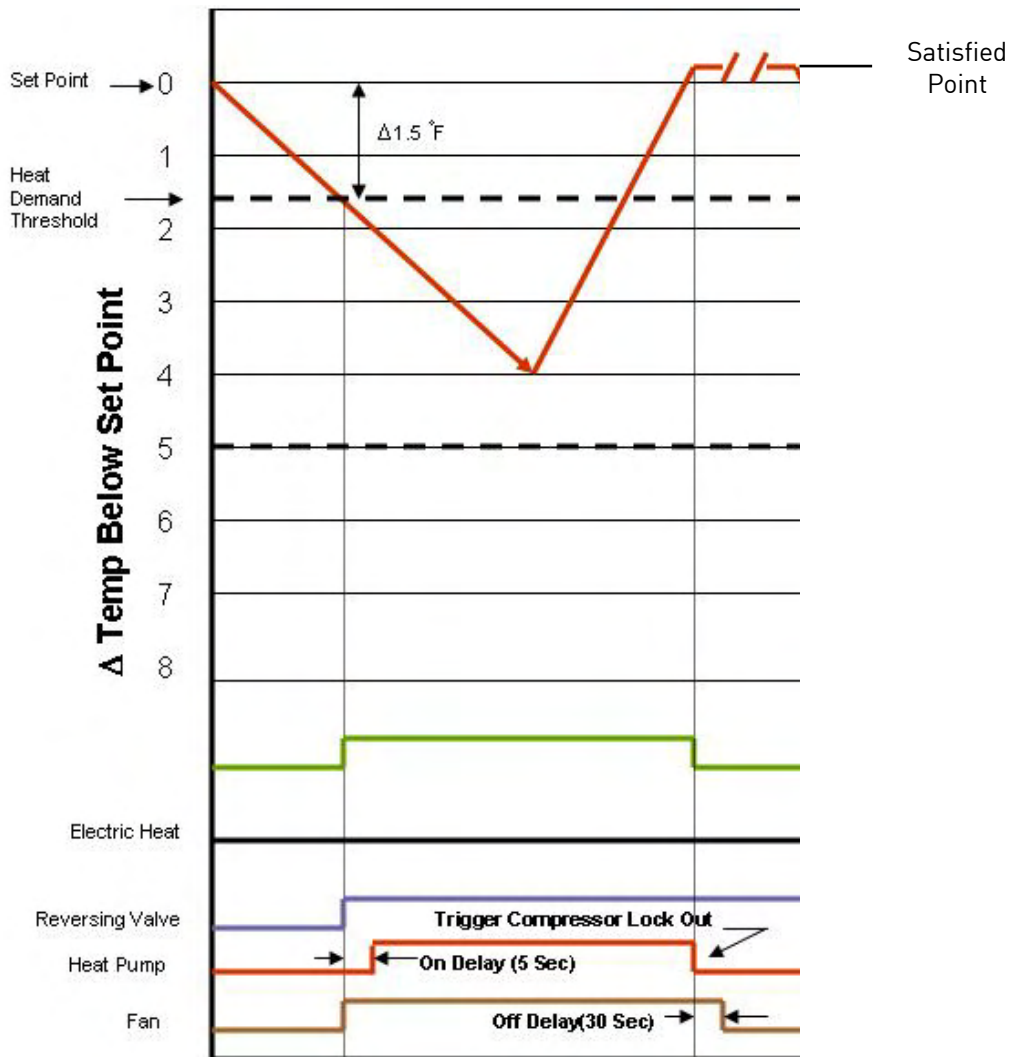

Figure 348 (Heat Control (Heat Pump Only))

KHS10B10A Heat Pump Defrost Cycle Operation

The defrost in this unit is an active reverse cycle. The defrost control runs in the background and determines when a defrost cycle is required. Once initiated, the defrost cycle runs to completion. The defrost cycle can only be initiated when the heat pump is in operation. The compressor will not be turned off to avoid activating the compressor's time delay. The reversing valve will be switched to the cool mode position. The indoor fan/blower will be turned off. Once the defrost cycle is finished, the system should re-enter a heating demand cycle if required. When the heat pump run time is 60 minutes or greater with an outdoor coil temperature of 26F degrees or lower, the control will run an active defrost for up to 6 minutes. When the temperature at the outdoor coil reaches 54F degrees, the heat pump heat will resume.

OPERATION

Heating Fan Delay

This is only for fan Mode Auto (Fan cycles with cool/heat operation) and not for continuous fan mode. When unit cycles Heating ON – starts the fan 5 seconds EARLY. When unit cycles Heating OFF – DELAYS the fan off for 15 seconds.

Fan Speed Change Delay

Relay activation is delayed by a minimum number of seconds. The default for this value is 2 seconds and is used to eliminate relay chatter.

System Mode Fan Only

The fan is turned on and runs at the specified manually set speed.

Only the Fan is turned on. Cool or Heat operation are off.

(This is different than FAN MODE ON where the fan is on with the cool or heat operation).

Fan Only Rules

1. If the SYSTEM FAN ONLY MODE is selected, the Auto fan mode is disabled, and the fan mode is forced to continuous. In addition, the auto fan speed is disabled. If the user presses the fan speed key, the menu will skip over the auto selection. The set point temperature display is off.
2. Any fan speed may be manually selected during Fan Only Mode.

Fan Operation (Front Panel Mode)

Heat – Cool – Auto – Fan Only

Cooling only models (Model numbers with the prefix KCS or KCM) have 4 speeds. All other Models have 3 speeds.

Fan ICON Detail

The system may have a 3 or 4 speed fan. The Fan Speed ICON will Display as LOW, MED, HI, or MAX depending on which speed is selected .

OPERATION

General Knowledge Sequence Of Refrigeration

A good understanding of the basic operation of the refrigeration system is essential for the service technician. Without this understanding, accurate troubleshooting of refrigeration system problems will be more difficult and time consuming, if not (in some cases) entirely impossible. The refrigeration system uses four basic principles (laws) in its operation they are as follows:

1. "Heat always flows from a warmer body to a cooler body."
2. "Heat must be added to or removed from a substance before a change in state can occur"
3. "Flow is always from a higher pressure area to a lower pressure area."
4. "The temperature at which a liquid or gas changes state is dependent upon the pressure."

The refrigeration cycle begins at the compressor. Starting the compressor creates a low pressure in the suction line which draws refrigerant gas (vapor) into the compressor. The compressor then "compresses" this refrigerant vapor, raising its pressure and its (heat intensity) temperature.

The refrigerant leaves the compressor through the discharge Line as a hot High pressure gas (vapor). The refrigerant enters the condenser coil where it gives up some of its heat. The condenser fan moving air across the coil's finned surface facilitates the transfer of heat from the refrigerant to the relatively cooler outdoor air.

When a sufficient quantity of heat has been removed from the refrigerant gas (vapor), the refrigerant will "condense" (i.e. change to a liquid). Once the refrigerant has been condensed (changed) to a liquid it is cooled even further by the air that continues to flow across the condenser coil.

The design determines at exactly what point (in the condenser) the change of state (i.e. gas to a liquid) takes place. In all cases, however, the refrigerant must be totally condensed (changed) to a Liquid before leaving the condenser coil.

The refrigerant leaves the condenser Coil through the liquid line as a warm high pressure liquid. It next will pass through the refrigerant drier (if equipped). It is the function of the drier to trap any moisture present in the system, contaminants, and large particulate matter.

The liquid refrigerant next enters the metering device. The metering device is a capillary tube. The purpose of the metering device is to "meter" (i.e. control or measure) the quantity of refrigerant entering the evaporator coil.

In the case of the capillary tube this is accomplished (by design) through size (and length) of device, and the pressure difference present across the device.

Since the evaporator coil is under a lower pressure (due to the suction created by the compressor) than the liquid line, the liquid refrigerant leaves the metering device entering the evaporator coil. As it enters the evaporator coil, the larger area and lower pressure allows the refrigerant to expand and lower its temperature (heat intensity). This expansion is often referred to as "boiling" or atomizing. Since the unit's blower is moving indoor air across the finned surface of the evaporator coil, the expanding refrigerant absorbs some of that heat. This results in a lowering of the indoor air temperature, or cooling.

The expansion and absorbing of heat cause the liquid refrigerant to evaporate (i.e. change to a gas). Once the refrigerant has been evaporated (changed to a gas), it is heated even further by the air that continues to flow across the evaporator coil.

The particular system design determines at exactly what point (in the evaporator) the change of state (i.e. liquid to a gas) takes place. In all cases, however, the refrigerant must be totally evaporated (changed) to a gas before leaving the evaporator coil.

The low pressure (suction) created by the compressor causes the refrigerant to leave the evaporator through the suction line as a cool low pressure vapor. The refrigerant then returns to the compressor, where the cycle is repeated.

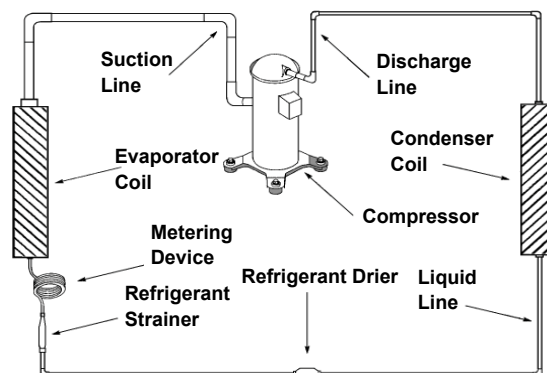

Figure 349 (Refrigeration Sequence Of Operation)

ROUTINE MAINTENANCE

Remove and Install Front Cover -Kuhl



Remove the decorative front cover.

1. Using a 1/4" nut driver loosen the four (4) captive screws as shown in figure 401

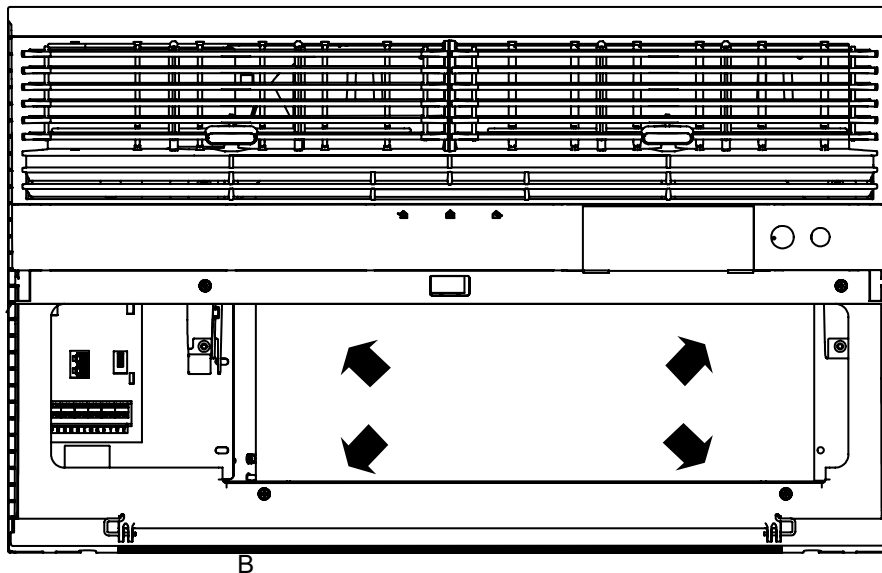

Figure 401 (Remove and Install the Front Cover)

Install the decorative front cover.

1. Tighten the four (4) captive screws as indicated by the arrows in the figure above before closing the front panel (do not over tighten). Ensure the filter is in place. Make sure curtains do not block the side air intake
2. Notes on reattaching the decorative front cover:
Align the cord notch over the cord and center the fresh air lever.
Align the cover over the User Interface (UI) to ensure it is clear around it and it does not depress any buttons. If not installed correctly the wrench alert symbol could flash.

ROUTINE MAINTENANCE

Remove and Install Front Cover -Kuhl Q

⚠ WARNING	
	ELECTRIC SHOCK HAZARD Disconnect power to the unit before servicing. Failure to follow this warning could result in serious injury or death.

Remove the decorative front cover.

1. Remove EntryGard™ screws if installed.
2. Open the decorative front cover door.
3. Locate and disconnect electronic control power cable harness.
4. Using a 1/4" nut driver, remove 4 screws attaching decorative front cover. Save to reinstall later.
5. Remove decorative front cover. Store in a safe place to reinstall later.

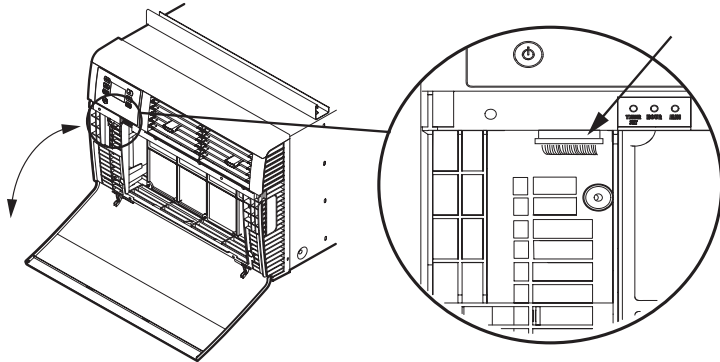

Install the decorative front cover.

1. Reinstall the 4 screws attaching decorative front cover.
2. Locate and reconnect electronic control power cable harness.
3. Close the decorative front cover door.
4. Reinstall the EntryGard™ screws if installed.

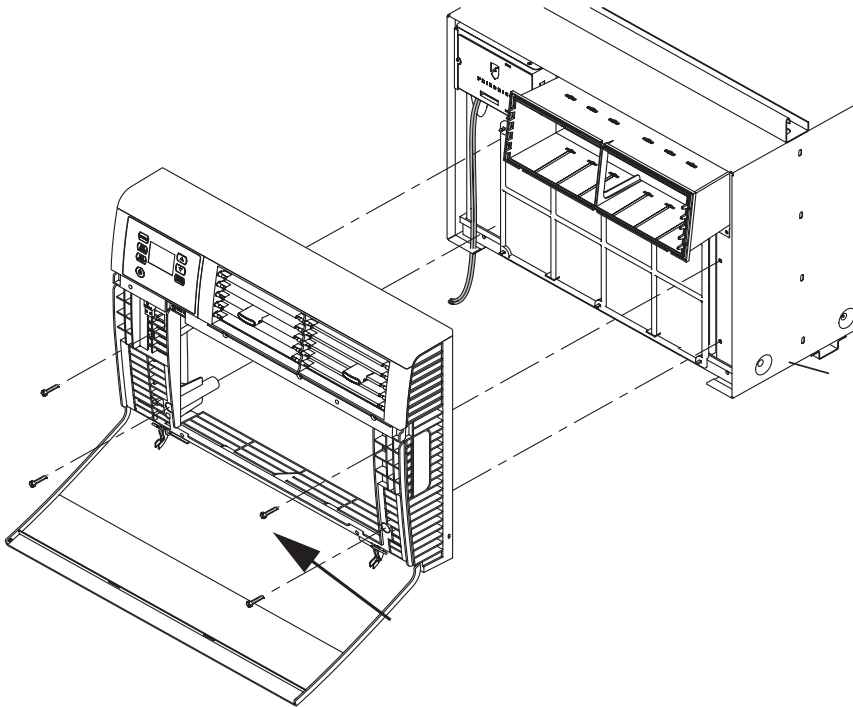

Figure 402 (Remove and Install the Front Cover)

ROUTINE MAINTENANCE

Remove and Install Front Cover -Wallmaster



Remove the decorative front cover.

1. Remove the FRONT PANEL. Using the handles, pull panel out until it is released from the two retaining snaps. Place the cover aside carefully.
2. Remove the filter by pulling it from the handles releasing it from the slots on the frame. Wash the filter with water to remove all dust and then rinse, remove water excess and let it dry. Do not twist. Remove the intake grill by applying slight outward pressure on the chassis removal handles and popping grill out of slots.
3. Remove the 4 screws and remove the decorative front assembly.

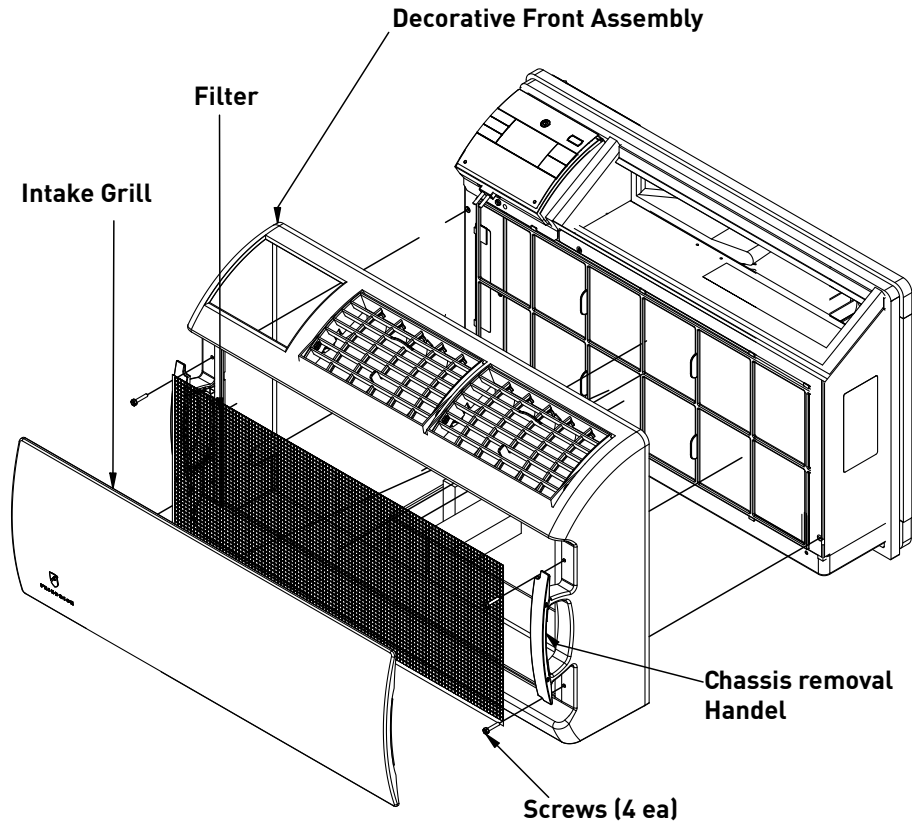

Figure 403 (Remove and Install the Decorative Front Assembly)

Install the decorative front cover.

1. Install the front decorative assembly with 4 screws .
2. Install the filter by inserting each tab in their respective slot.
3. Install Intake grill by applying slight outward pressure on the chassis removal handle.

ROUTINE MAINTENANCE

Coils & Chassis

NOTE: Do not use a caustic (alkaline) or acidic cleaning agent on coils or base pan. Use a biodegradable cleaning agent and de greaser. The use of harsh cleaning materials may lead to deterioration of the aluminum fins or the coil end plates.

The indoor coil and outdoor coils and base pan should be inspected periodically (annually or semi-annually) and cleaned of all debris (lint, dirt, leaves, paper, etc.) as necessary. Under extreme conditions, more frequent cleaning may be required. Clean the coils with and base pan with a coil comb or soft brush and compressed air or vacuum. A low pressure washer device may also be used; however, you must be careful not to bend the aluminum fin pack. Use a sweeping up and down motion in the direction of the vertical aluminum fin pack when pressure cleaning coils.

NOTE: It is extremely important to insure that none of the electrical and/or electronic parts of the unit get wet when cleaning. Be sure to cover all electrical components to protect them from water or spray.

Decorative Front

Use a damp (not wet) cloth when cleaning the control area to prevent water from entering the unit, and possibly damaging the electronic control.

The decorative front and the cabinet can be cleaned with warm water and a mild liquid detergent. Do NOT use solvents or hydrocarbon based cleaners such as acetone, naphtha, gasoline, benzene, etc.

The indoor coil can be vacuumed with a dusting attachment if it appears to be dirty. DO NOT BEND FINS. The outdoor coil can be gently sprayed with a garden hose.

The air filter should be inspected periodically and cleaned if needed by vacuuming with a dust attachment or by cleaning in the sink using warm water and a mild dish washing detergent. Dry the filter thoroughly before reinstalling. Use caution, the coil surface can be sharp.

Fan Motor & Compressor

The fan motor & compressor are permanently lubricated and require no additional lubrication.

Wall Sleeve

Inspect the inside of the wall sleeve and drain system periodically (annually or semi-annually) and clean as required. Under extreme conditions, more frequent cleaning may be necessary. Clean both of these areas with an antibacterial and antifungal cleaner. Rinse both items thoroughly with water and ensure that the drain outlets are operating correctly. Check the sealant around the sleeve and reseal areas as needed.

Blower Wheel / Housing / Condenser Fan / Shroud

Inspect the indoor blower and its housing, evaporator blade, condenser fan blade and condenser shroud periodically (yearly or bi-yearly) and clean of all debris (lint, dirt, mold, fungus, etc.). Clean the blower housing area and blower wheel with an antibacterial / antifungal cleaner. Use a biodegradable cleaning agent and de greaser on condenser fan and condenser shroud. Use warm or cold water when rinsing these items. Allow all items to dry thoroughly before reinstalling them.

Electrical / Electronic

Periodically (at least yearly or bi-yearly) inspect all control components: electronic, electrical and mechanical, as well as the power supply. Use proper testing instruments (voltmeter, ohmmeter, ammeter, wattmeter, etc.) to perform electrical tests. Use an air conditioning or refrigeration thermometer to check room, outdoor and coil operating temperatures.

Air Filter

To ensure proper unit operation, the air filter should be cleaned at least monthly, and more frequently if conditions warrant. The unit must be turned off before the filter is cleaned.

ROUTINE MAINTENANCE

Standard Filter Removal / Installation Instructions - Kuhl

1. Swing the door open, See Figure 404, and remove the filter by grasping the filter grip and pushing the filter holder upward and outward. See Figure 405.
2. Slide the filter grip out from the filter as shown in Figure 406.

NOTE: Make sure the front frame with the mesh filter is facing you.

3. Swing the front frame open. See Figure 407. Clean the front frame by washing the dirt from the filter. Use a mild soap solution if necessary. Allow filter to dry.
4. Install the filter grip back into the filter by sliding it into the filter.

NOTE: The filter handle slides into the frame in only one direction. If the tab in the frame stops the handle from sliding in, slide the handle from the other direction. **DO NOT FORCE THE HANDLE INTO THE FRAME.**

5. Install the filter back into the unit. Follow the instructions on the inside of the front door.

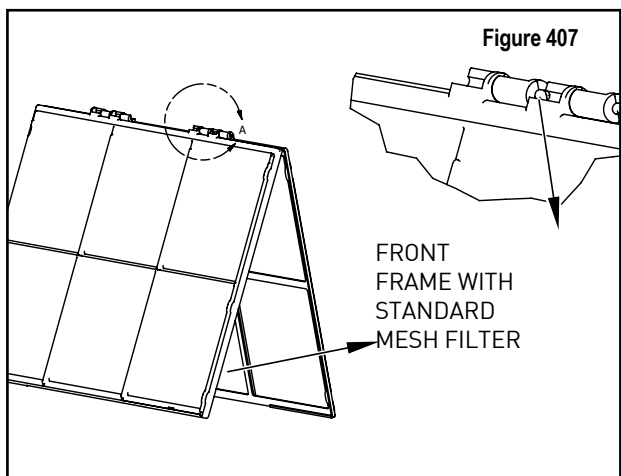
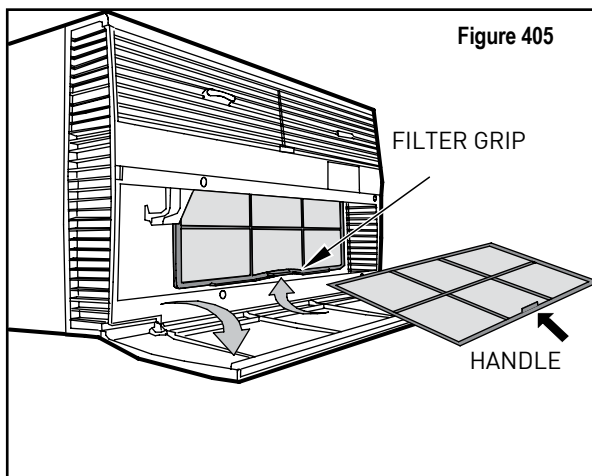
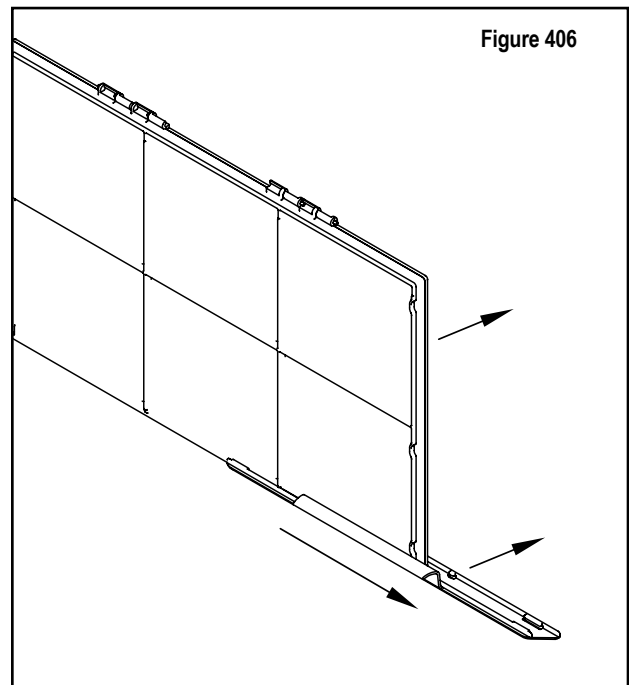
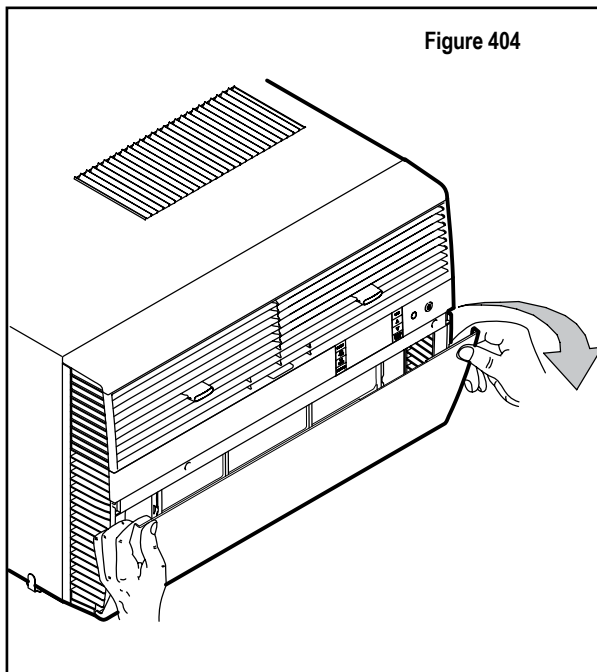

ROUTINE MAINTENANCE

Premium Carbon Filter Removal / Installation Instructions -Kuhl

1. Remove the filter per Standard Filter Removal Installation Refer to Figure 404 and 405.
2. Hold the filter at the top and slide the grip out as shown on Figure 406.
3. If you already have a carbon filter installed remove the dirty filter by laying the filter down and swinging open the front frame as shown in Figure 407.

NOTE: Make sure the frame with the mesh is facing toward you.

4. Place the new carbon filter on the top of the back filter frame. The carbon filter has been cut to the correct dimension and should fit within the frame as shown in Figure 409.

NOTE: The carbon filter is not a reusable filter, and needs to be replaced every three months for optimum efficiency.

5. Slide the filter handle back on to hold the frames together and slide the assembly into the unit as per the instructions on the door.

NOTE: The filter handle slides into the frame in only one direction. If the tab in the frame stops the handle from sliding in, slide the handle from the other direction. **DO NOT FORCE THE HANDLE INTO THE FRAME.**

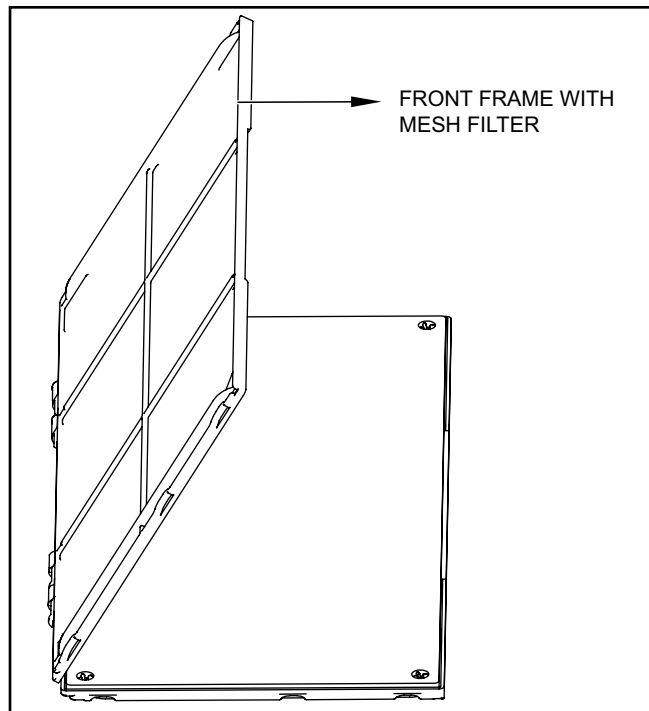

Figure 408

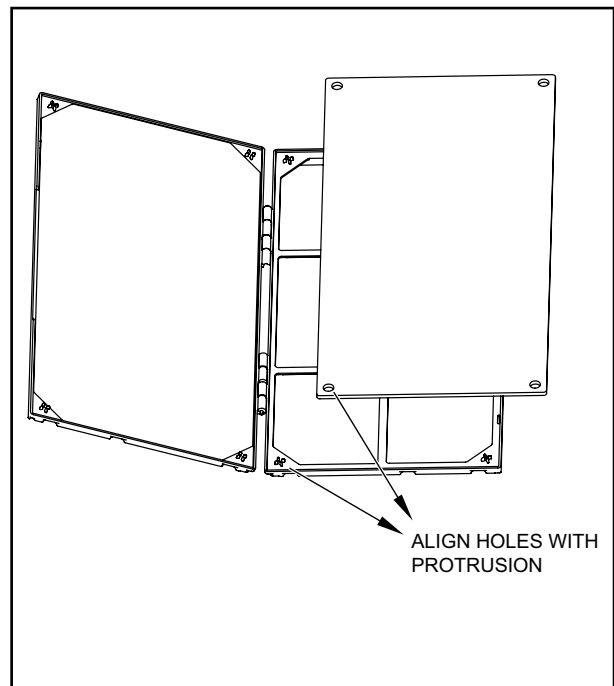

Figure 409

ROUTINE MAINTENANCE

Filter Removal / Installation Instructions - Kuhl Q

1. Swing the door open, See Figure 410, and remove the filter by grasping the filter grips and pulling the bottom towards you. . See Figure 411.
2. Clean the front frame by removing the carbon filter (if installed) and washing the dirt from the filter. Use a mild soap solution if necessary. Allow filter to dry.

NOTE: The carbon filter is not a reusable filter, and needs to be replaced every three months for optimum efficiency.

3. Install new carbon filter (optional) by aligning holes on carbon filter with tabs on mesh filter. (See Figure 412).
4. Install filter and close door. See Figures 409 and 410.

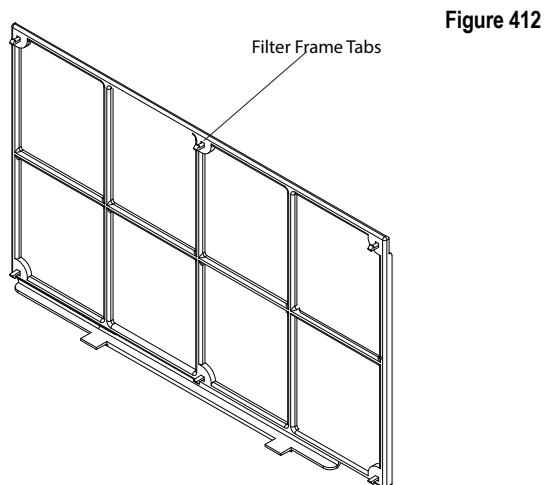
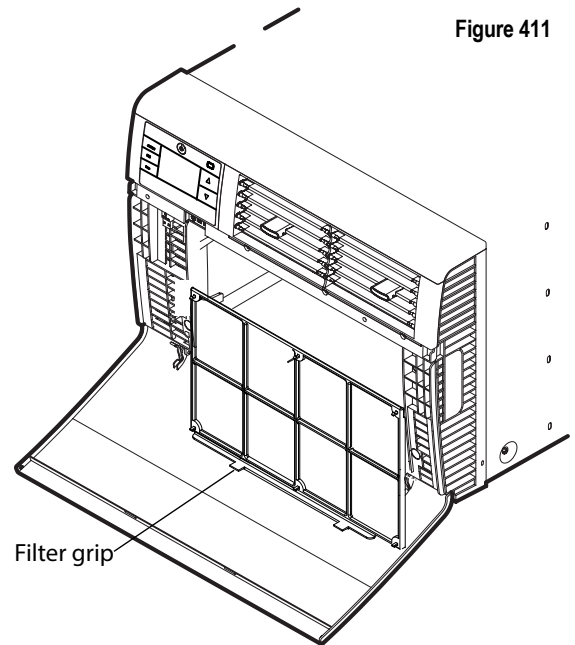
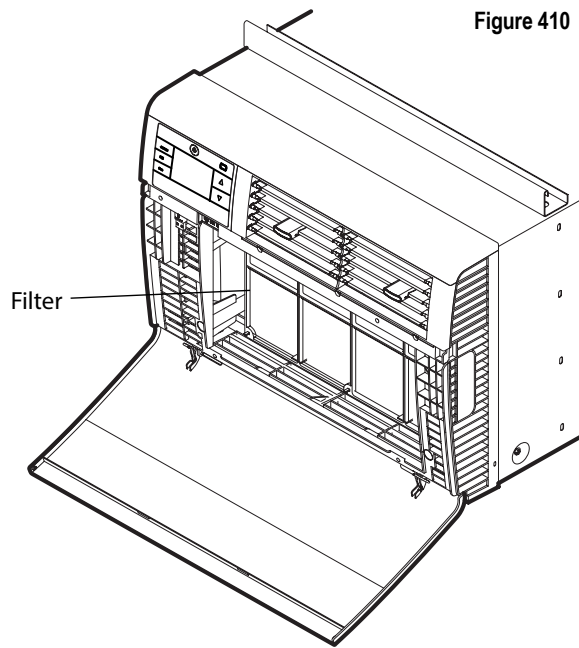

REMOVE AND INSTALL THE CHASSIS

Remove The Chassis - Kuhl

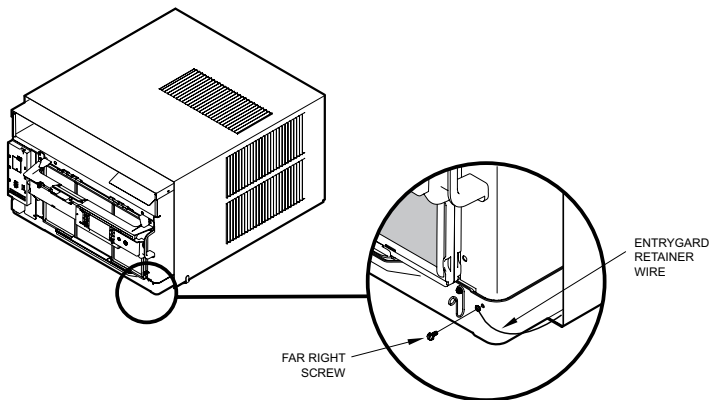
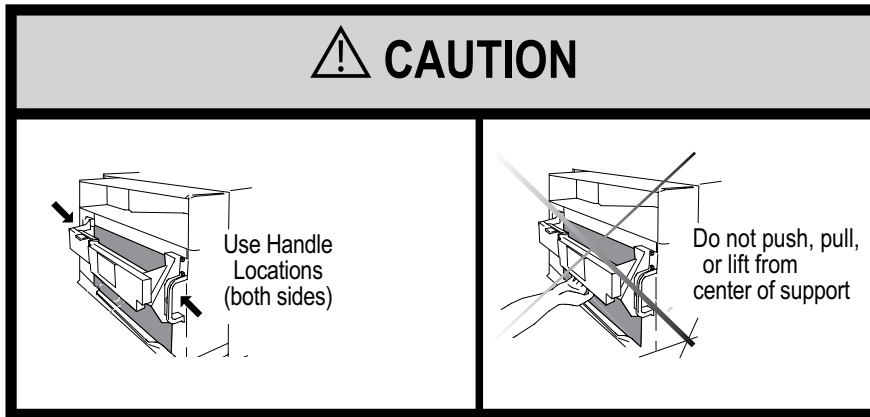
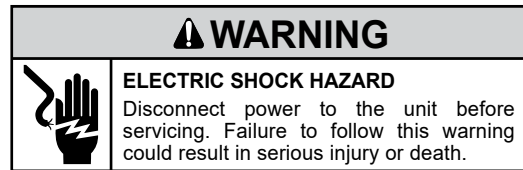

Figure 501 (Chassis Removal and Installation)



1. [Remove the decorative front cover.](#) See Routine Maintenance Figure 401.
2. Remove the chassis Entrygard Retainer Wire by removing the screw at the front right bottom corner. Save this screw for reattachment after reinstalling the chassis. See Figure 501.
3. Hold the cabinet stationary then use the hand grips on both ends of the control unit support bracket to pull the chassis out of the cabinet .

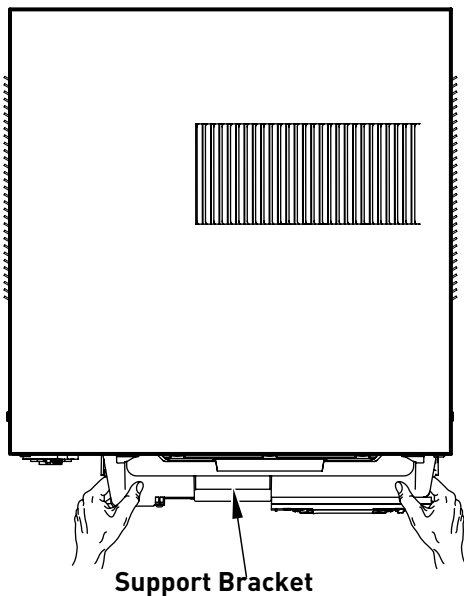
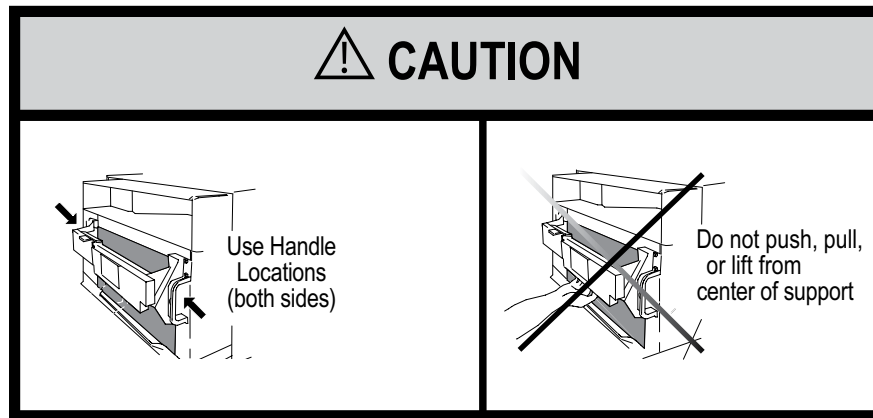

Figure 502 (Support Bracket)

REMOVE AND INSTALL THE CHASSIS

Install The Chassis -Kuhl



1. Carefully team lift the chassis and set it into the cabinet.
2. Slide the chassis stopping approximately 3" from full insertion.
3. Insert the chassis seal gasket (See Figure 503) one inch deep between the chassis and the cabinet. A paint stir stick or ruler might be helpful here. Begin inserting the gasket at either bottom corner and go up the side, across the top, and down the opposite side. Then push the chassis all the way into the cabinet.

NOTE: If the chassis seal gasket is not installed or installed improperly, the operation of the unit will be negatively affected. Operational noise and outside noise will also amplified.

4. Slide the chassis in the remaining three (3) inches.
5. Reattach the EntryGard™ chassis and EntryGard™ retainer wire..

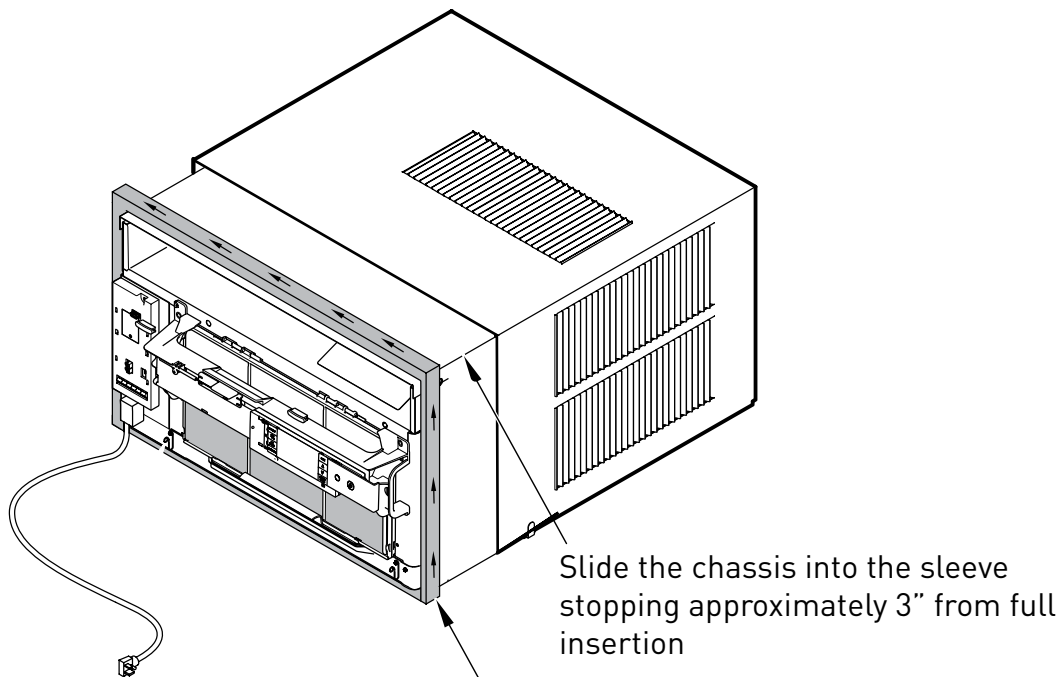

CHASSIS SEAL GASKET

NOTE WHEN INSTALLING THE CHASSIS SEAL GASKET, BEGIN AT EITHER BOTTOM CORNER AND GO UP THE SIDE & ACROSS THE TOP & DOWN THE OPPOSITE SIDE.

Figure 503 (Chassis Installation)

REMOVE AND INSTALL THE CHASSIS

Kuhl Q

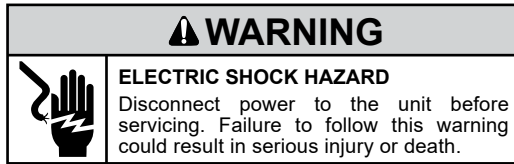

Remove the chassis

1. Remove the EntryGard™ Screws. (Refer to Figure 504)
2. Hold the cabinet stationary then carefully slide the unit out of the sleeve. Make sure to fully support the unit. (Refer to Figure 505)

Install the Chassis

1. Carefully team lift the chassis and set it into the cabinet. (Refer to Figure 504)
2. Slide the chassis into the cabinet
4. Reinstall the EntryGard™ screws.. (Refer to Figure 505)

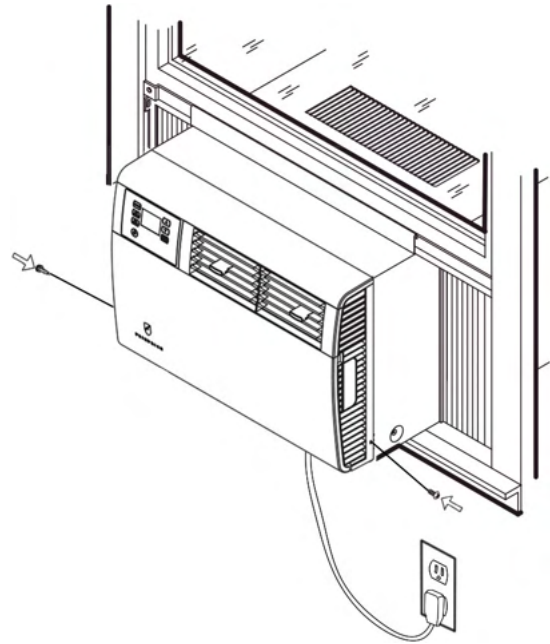

Figure 504 (Remove Entry Gard Screws)

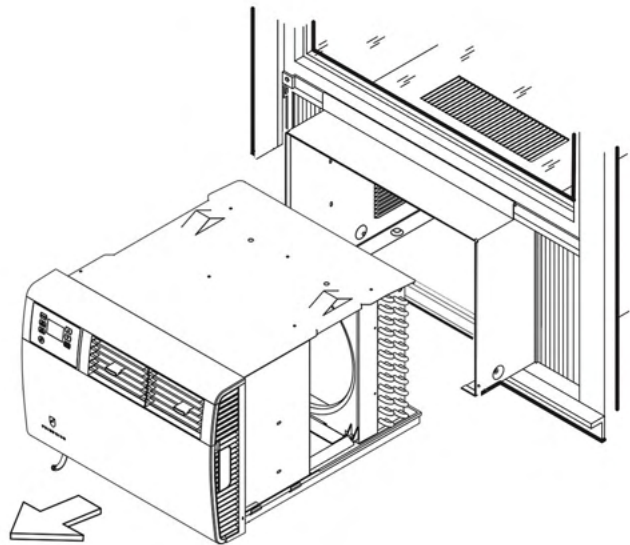



Figure 505 (Remove Chassis)

REMOVE AND INSTALL THE CHASSIS

Wallmaster

⚠ WARNING	
	ELECTRIC SHOCK HAZARD Disconnect power to the unit before servicing. Failure to follow this warning could result in serious injury or death.

Remove Chassis

1. Unplug the unit..
2. Remove the front grill. See Routine Maintenance Figure 403.
3. Remove the clamped drain hose from the nipple if installed.
4. Hold the cabinet stationary then use the hand grips on both ends of the decorative front assembly to pull the chassis out of the cabinet .

Note: If Ground wire is screwed into the Sleeve, disconnect before attempting to pull unit all the way out..

Reinstall Chassis

1. Check the sleeve to be certain it has been correctly installed in the wall. Remove the front panel on the WSE SLEEVE. Remove the rear WEATHER PANEL. Reverse grille. Place lower edge into sleeve tab (Friedrich logo facing out). Align slots with the screw holes. Secure grille with screws.
 - A. Check the anchor screw. There should be four (4) in the WSE SLEEVE (two in each side).
 - B. Determine if the sleeve has a downward slope of 3/8 bubble to the outside..
 - C. Check to be sure the sleeve has been sealed around all edges with an industrial type caulking on both the outside and inside to prevent rain entry.

2. Check the electrical receptacle to see that it conforms to the requirements for the chassis model to be installed. See figure 207 for the receptacle requirements.

3. Remove the chassis from the shipping carton.

4. Remove the FRONT PANEL. Using the handles, pull panel out until it is released from the two retaining snaps. Place the cover aside carefully.

5. Lift the chassis by the basepan and slide it into the front of the sleeve. (Obtain assistance as needed.)

6. Turn the unit at an angle to allow clearance to secure the grounding wire which has a red tag on it. Drive a grounding screw through the lug on the grounding wire, through the wall sleeve, and into the wall frame.

7. Push the chassis all the way into the sleeve, using the plastic front handles, so that the front panel meets the front edge of the shell.

NOTE: Chassis comes with pre-installed seal gasket.

8. Check that filter is properly installed, and reinstall front panel.

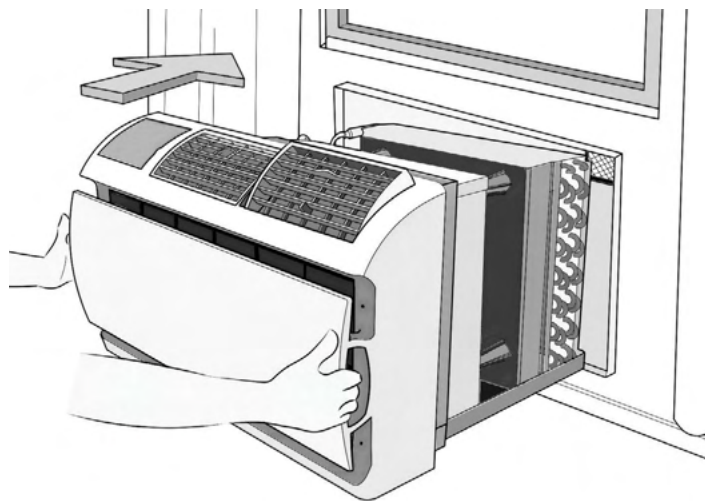

Figure 506 (Remove and Install the Chassis)

TROUBLESHOOTING

Room Air Conditioner Unit Performance Test Data Sheet

JOB NAME _____ TECH'S NAME _____

DATE _____ MODEL# _____ SERIAL # _____

CHECK THE INSTALLATION	ACCEPTABLE YES	NOT ACCEPTABLE NO
IS A CHASSIS GASKET INSTALLED?	_____	_____
IS THE FRESH / EXHAUST AIR VENT OPEN?	_____	_____
IS A FRIEDRICH SLEEVE INSTALLED?	_____	_____
IS A FRIEDRICH OUTDOOR GRILLE INSTALLED?	_____	_____
IS MAINTENANCE BEING PERFORMED?	_____	_____

ELECTRICAL

LINE VOLTAGE (STATIC) _____ VOLTS

START UP VOLTAGE _____ VOLTS

AMPERAGE DRAW (COOL) _____ AMPS

AMPERAGE DRAW (HEAT) _____ AMPS

COMPRESSOR

RUNNING AMPERAGE DRAW _____ AMPS

INDOOR CONDITIONS

INDOOR AMBIENT TEMPERATURE _____ F

RELATIVE HUMIDITY (RH) INDOOR _____ %

DISCHARGE AIR TEMPERATURE (INDOOR)(COOL) _____ F

DISCHARGE AIR TEMPERATURE (INDOOR)(HEAT) _____ F

RETURN AIR TEMPERATURE (INDOOR)(COOL) _____ F

RETURN AIR TEMPERATURE (INDOOR) (HEAT) _____ F

OUTDOOR TEMPERATURE

OUTDOOR AMBIENT TEMPERATURE _____ F

RH OUTDOOR RELATIVE HUMIDITY _____ %

DISCHARGE AIR TEMPERATURE (OUTDOOR)(COOL) _____ F

DISCHARGE AIR TEMPERATURE (OUTDOOR)(HEAT) _____ F

INTAKE AIR TEMPERATURE (OUTDOOR)(COOL) _____ F

INTAKE AIR TEMPERATURE (OUTDOOR)(HEAT) _____ F

COOLING OR HEATING AREA

AREA W _____ * L _____ = FEET SQUARED

FOR A GENERAL GUIDE REFER TO SIZING GUIDE TO THE RIGHT

FOR EXACT LOAD CALCULATIONS CONSULT MANUAL J OR M.

Figure 601 (Test Data Sheet)

Cooling Sizing Guide

AREA TO BE CONDITIONED IN SQ. FT.	APPROXIMATE COOLING BTU REQUIRED
100 - 150	5000
150 - 250	6000
250 - 300	7000
300 - 350	8000
350 - 400	9000
400 - 450	10000
450 - 550	12000
550 - 700	14000
700 - 1000	18000
1000 - 1200	21000
1200 - 1400	23000
1400 - 1500	24000
1500 - 2000	30000
2000 - 2500	34000

Guide based on normal room insulation, average number of sun exposed windows and two person occupancy.

1. If heavily shaded, reduce cooling Btus required by 10%
2. If very sunny, increase cooling Btus required by 10%
3. Add 500 Btus per person over 2 people
4. Add 4,000 Btus if the area is a kitchen

Figure 602 (Cooling Sizing Guide)

TROUBLESHOOTING

Diagnostic Codes

DIAG CODE	PROBLEM	CONTROL BOARD'S ACTION
1	Front Panel Button Stuck For More Than 20 Seconds	Continue to monitor for "OPEN" (Unstuck) switch. Do not process switch input. ENSURE FRONT COVER DOES NOT DEPRESS BUTTONS
3	Indoor Temperature Sensor is Open or Shorted	Set temp to 75°F in COOLING or 68°F in HEATING. Unit continues to operate
4	Indoor Coil Temperature Sensor is Open or Shorted	Control Board sets temp to a default of 40°F. Override sensor. Unit continues to operate.
5	Outdoor Coil Temperature Sensor is Open or Shorted	Sets temp to 20°F. Override sensor. Continue operation. Use Elec Heat if available for HEATING. If not available use HEAT PUMP if outdoor temp allows.
6	Outdoor Coil greater than 175° F	Turn Compressor off. Wait for the outdoor coil to be less than 150°F for more than 2 consecutive minutes.
7	Indoor Coil less than 30° F for 2 consecutive minutes	Turn compressor and electric heat off. When coil temp reaches 45°F resume operation after lockout time.
8	Unit Cycles greater than 9 Times per hour	Continue operation. Continue to monitor. Take no action. Log Only.
9	Unit Cycles less than 3 Times per Hour	Continue operation. Continue to monitor. Take no action. Log Only.
12	Discharge Air greater than 185°F	Shutdown electric heater. Wait for the discharge air temperature to be less than 100°F. Resume operation.
13	High Pressure Switch Open	Turn compressor off. Wait until pressure switch is no longer open. Resume operation after lockout time.
14	Discharge Air Temperature Sensor is Open or Shorted	Override Sensor. Set temp to 75°F. Continue to monitor. Set error code 14 ON.
16	Temperature Beyond Operating Limits	Ambient temp is less than 0°F or greater than 130°F. Turn off compressor, electric heat, and fan. When cleared resume operation.
22	Outdoor Coil Temperature less than 30°F for 2 consecutive Minutes	Only applicable to units with heat pump and electric heat. Turn off heat pump operation. Use electric heat to satisfy all heating demands. Cleared when outdoor coil temp is greater than 45°F.
23	Frost Protection.	Only applicable to heat pump only units. Active when Heat Pump run time exceeds 60 minutes with the outdoor coil temp less than 26°F. Runs active defrost for up to 6 minutes.

Figure 603 (Diagnostic Codes)

TROUBLESHOOTING

Troubleshooting Tips

Problem	Possible Cause	Possible Solution
Unit does not operate.	The power button is off or the set point temperature is satisfied.	Push the power button on and raise or lower temperature setting (as appropriate) to call for operation.
	The LCDI power cord is unplugged.	Plug into a properly grounded 3 prong receptacle. (See Electrical Rating Tables, Figure 206) for the proper receptacle type for your unit.
	The LCDI power cord has tripped (Reset button has popped out).	Press and release RESET (Listen for click. Reset button latches and remains in.) Check that the green LED light is on to resume operation.
	The circuit breaker has tripped or the supply circuit fuse has blown.	Reset the circuit breaker, or replace the fuse as applicable. If the problem continues, contact a licensed electrician.
	There has been a local power failure.	The unit will resume normal operation once power has been restored.
Unit Trips Circuit Breaker or Blows Fuses.	Other appliances are being used on the same circuit. (115 Volt only)	The unit requires a dedicated outlet circuit, not shared with other appliances.
	An extension cord is being used.	Do NOT use an extension cord with this or any other air conditioner.
	The circuit breaker or time-delay fuse is not of the proper rating.	Replace with a circuit breaker or time-delay fuse of the proper rating. (See Electrical Rating Tables, Figure 206) for the proper circuit breaker/fuse rating for your unit. If the problem continues, contact a licensed electrician.
LCDI Power Cord Trips (Reset Button Pops Out).	The LCDI power cord can trip (Reset button pops out) due to disturbances on your power supply line.	Press and release RESET (Listen for click. Reset button latches and remains in.) Check that the green LED light is on to resume normal operation.
	Electrical overload, overheating, or cord pinching can trip (Reset button pops out) the LCDI power cord.	Once the problem has been determined and corrected, press and release RESET (Listen for click. Reset button latches and remains in.) to resume normal operation.
	NOTE: A damaged power supply cord must be replaced with a new power supply cord obtained from the product manufacturer and must not be repaired.	
Unit Does Not Cool/Heat Room Sufficiently, or Cycles On And Off Too Frequently.	<ul style="list-style-type: none"> The return/discharge air grille is blocked. 	<ul style="list-style-type: none"> Ensure that the return and/or discharge air paths are not blocked by curtains, blinds, furniture, etc.
	<ul style="list-style-type: none"> Windows or doors to the outside are open. 	<ul style="list-style-type: none"> Ensure that all windows and doors are closed.
	<ul style="list-style-type: none"> The temperature is not set at a cool enough/warm enough setting. 	<ul style="list-style-type: none"> Adjust the Temperature control to a cooler or warmer setting as necessary.
	<ul style="list-style-type: none"> The filter is dirty or obstructed. 	<ul style="list-style-type: none"> Clean the filter, (see Routine Maintenance), or remove obstruction.
	<ul style="list-style-type: none"> The indoor coil or outdoor coil is dirty or obstructed. 	<ul style="list-style-type: none"> Clean the coils, (see Routine Maintenance), or remove obstruction.
	<ul style="list-style-type: none"> There is excessive heat or moisture (cooking, showers, etc.) in the room. 	<ul style="list-style-type: none"> Be sure to use exhaust vent fans while cooking or bathing and, if possible, try not to use heat producing appliances during the hottest part of the day.
	<ul style="list-style-type: none"> The temperature of the room you are trying to cool is extremely hot. 	<ul style="list-style-type: none"> Allow additional time for the air conditioner to cool off a very hot room.

Figure 717 (Troubleshooting Tips)

TROUBLESHOOTING

Tips continued

COMPLAINT	CAUSE	SOLUTION
Unit Does Not Cool/Heat Room Sufficiently, or Cycles On And Off Too Frequently (continued).	Operating in Cooling mode while the outside temperature is below 60 °F (16 °C).	Do not try to operate your air conditioner in the cooling mode when the outside temperature is below 60 °F (16 °C). The unit will not cool properly, and the unit may be damaged.
	The digital control is set to fan cycling mode.	Since the fan does not circulate the room air continuously at this setting, the room air does not mix as well and hot (or cold) spots may result. Using the continuous fan setting is recommended to obtain optimum comfort levels.
	The air conditioner has insufficient cooling capacity to match the heat gain of the room.	Check the cooling capacity of your unit to ensure it is properly sized for the room in which it is installed. Room air conditioners are not designed to cool multiple rooms.
	The air conditioner has insufficient heating capacity to match the heat loss of the room.	Check the heating capacity of your unit. Air conditioners are sized to meet the cooling load, and heater size is then selected to meet the heating load. In extreme northern climates, room air conditioners may not be able to be used as a primary source of heat.
Unit Runs Too Much.	This may be due to an excessive heat load in the room.	If there are heat producing appliances in use in the room, or if the room is heavily occupied, the unit will need to run longer to remove the additional heat.
	It may also be due to an improperly sized unit.	Be sure to use exhaust vent fans while cooking or bathing and, if possible, try not to use heat producing appliances during the hottest part of the day.
Compressor does not run.	Low voltage	Check voltage at compressor. 115V & 230V units will operate at 10% voltage variance
	Temperature not set cold enough or room air thermistor inoperative	Set temperature to lower than ambient position. Test thermistor and replace if inoperative.
	Compressor hums but cuts off on overload	Direct test compressor.
	Open overload	Test overload protector & replace if inoperative
	Open capacitor	Test capacitor & replace if inoperative
	Inoperative power button	Test for continuity in all positions. Replace User Interface if switch inoperative.
	Broken, loose or incorrect wiring	Refer to appropriate wiring diagrams to check wiring. Correct as needed.

TROUBLESHOOTING

COMPLAINT	CAUSE	SOLUTION
Fan motor does not run.	Inoperative system button	Test button & replace user interface if inoperative
	Broken, loose or incorrect wiring	Refer to applicable wiring diagram
	Open capacitor	Test capacitor & replace if inoperative
	Fan speed button defective	Replace user interface if inoperative
	Inoperative fan motor	Test fan motor & replace if inoperative (be sure internal over-load has had time to reset)
Does not cool or only cools slightly	Undersized unit	Refer to industry standard sizing chart
	Indoor ambient thermistor open or shorted	See diagnostic codes and replace thermistor if needed.
	Dirty filter	Clean as recommended in Owner's Manual
	Dirty or restricted condenser or evaporator coil	Use pressure wash or biodegradable cleaning agent to clean
	Poor air circulation	Adjust discharge louvers. Use high fan speed
	Fresh air or exhaust air door open	Close doors. Instruct customer on use of this feature
	Low capacity - undercharge	Check for leak & make repair
Unit does not run	Compressor not pumping properly	Check amperage draw against nameplate. If not conclusive, make pressure test
	Fuse blown or circuit tripped	Replace fuse, reset breaker. If repeats, check fuse or breaker size. Check for shorts in unit wiring & components
	Loose or disconnected wiring control board or other components	Check wiring & connections. Reconnect per wiring diagram
Evaporator coil freezes up	The LCDI power cord has tripped (Reset button has popped out).	Press and release RESET (Listen for click. Reset button latches and remains in.) Check that the green LED light is on to resume operation.
	Dirty filter	Clean filter (see Routine Maintenance)
	Restricted airflow	Check for dirty or obstructed coil. Clean coil (refer to routine Maintenance)
	Inoperative thermistor	Check Diagnostic Codes. Check Thermistors and replace as necessary.
	Short of refrigerant	De-ice coil & check for leak
	Inoperative fan motor	Test fan motor & replace if inoperative
Compressor runs continually & does not cycle off	Partially restricted capillary tube	De-ice coil. Replace capillary tube
	Excessive heat load	Unit undersized. Test cooling performance & replace with larger unit if needed. See sizing chart.
	Restriction in line	Check for partially iced coil & check temperature split across coil
	Thermistor shorted	Replace thermistor or electronic control board

TROUBLESHOOTING

Tips continued

COMPLAINT	CAUSE	SOLUTION
Electronic control board does not turn unit off	Compressor relay contacts stuck	Replace electronic control board
	Incorrect wiring	Refer to appropriate wiring diagrams
	Unit undersized for area to be cooled	Refer to industry standard sizing chart
	Defective thermistor	Replace thermistor or electronic control board
Compressor runs for short periods only.	Incorrect wiring	Refer to appropriate wiring diagram
	Shorted or incorrect capacitor	Test capacitor and replace if needed.
	Restricted or low air flow through condenser coil or evaporator coil	Check for proper fan speed or blocked coils. Correct as needed.
	Compressor running abnormally hot	Check for kinked discharge line or restricted condenser. Refrigerant overcharge. Check amperage, connections.
Unit does not turn on	No power	Check power supply. Check LCDI plug. Check wire connections. Check if panel is locked.
	Incorrect wiring	Refer to appropriate wiring diagram
	Defective thermistor	Replace thermistor or electronic control board
Noisy operation	Poorly installed	Refer to Installation Manual for proper installation
	Fan blade striking chassis	Reposition - adjust motor mount
	Compressor vibrating	Check that compressor grommets have not deteriorated. Check that compressor mounting parts are not missing
	Improperly mounted or loose cabinet parts refrigerant tubes	Check assembly & parts for looseness, rubbing & rattling pipes, etc.
Water Leaks into Room	Evaporator drain pan overflowing	Clean obstructed drain trough
	Condensation forming underneath base pan	Evaporator drain pan broken or cracked. Reseal or replace. No chassis gasket installed. Install chassis gasket
	Poor installation resulting in rain entering the room	Check installation instructions. Reseal as required
	Condensation on discharge grille louvers	Dirty evaporator coil. Clean coils (See Routine Maintenance) Environmental phenomena: point supply louvers upward. Put on high fan.
	Chassis gasket not installed	Install gasket, per Installation manual
	Downward slope of unit is too steep inward	Refer to installation manual for proper installation

TROUBLESHOOTING

COMPLAINT	CAUSE	SOLUTION
Water “spitting” into room	Sublimation: When unconditioned saturated, outside air mixes with conditioned air, condensation forms on the cooler surfaces	Ensure that foam gaskets are installed in between window panes & in between the unit & the sleeve. Also, ensure that fresh air/exhaust vents (on applicable models) are in the closed position & are in tact
	Downward pitch of installation is too steep towards back of unit	Follow installation instructions to ensure that downward pitch of installed unit is no less than 1/4” & no more than 3/8”
	Restricted coil or dirty filter	Clean & advise customer of periodic cleaning & maintenance needs of entire unit
Excessive moisture	Insufficient air circulation thru area to be air conditioned	Adjust louvers for best possible air circulation
	Inadequate vapor barrier in building structure; particularly floors.	Advise customer
Unit short cycles	Defective thermistor	Replace thermistor or electronic control board
	Unit oversized	See sizing chart. Correct as needed.
	Chassis seal gasket not sealing or absent causing unit to short cycle	Check gasket. Reposition or replace as needed
	Restricted coil or dirty filter	Clean & advise customer of periodic cleaning & maintenance needs of entire unit
Prolonged off cycles	Defective indoor ambient thermistor or electronic control board	Check alarms. Replace thermistor or electronic control board
Outside water leaks	Evaporator drain pan cracked or obstructed	Repair, clean or replace as required
	Obstructed condenser coil	Use pressure wash or biodegradable cleaning agent to clean
	Fan blade/ slinger ring improperly positioned	Adjust fan blade to 1/2” of condenser coil fin pack

TROUBLESHOOTING

Cool with Heat Units

COMPLAINT	CAUSE	SOLUTION
Room temperature uneven (Heating cycle)	Bad indoor ambient thermistor	Check diagnostic codes. Check Thermistors. Replace as needed.
	Fan speed too low	Set at higher fan speed.
Does not heat adequately	Exhaust or fresh air door open	Check if operating properly. Instruct customer on proper use of control
	Dirty filter	Clean (See Routine Maintenance)
	Unit undersized	Check heat rise across coil. If unit operates efficiently, check if insulation can be added to attic or walls. If insulation is adequate, recommend additional unit or larger one
	Heater hi-limit control cycling on & off	Check for adequate fan air across heater. Check for open hi-limit control.
	Shorted or open supplementary heater	Do ohmmeter check.
	Incorrect wiring	Check applicable wiring diagram
Unit cools when heat is called for	Incorrect wiring	Refer to applicable wiring diagram
	Defective solenoid coil	Check for continuity of coil
	Reversing valve fails to shift	Block condenser coil & switch unit to cooling. Allow pressure to build up in system, then switch to heating. If valve fails to shift, replace valve.
Cooling adequate, but heating insufficient.	Reversing valve failing to shift completely; bypassing hot gas	De-energize solenoid coil, raise head pressure, energize solenoid to break loose. If valve fails to make complete shift, replace valve.

TROUBLESHOOTING

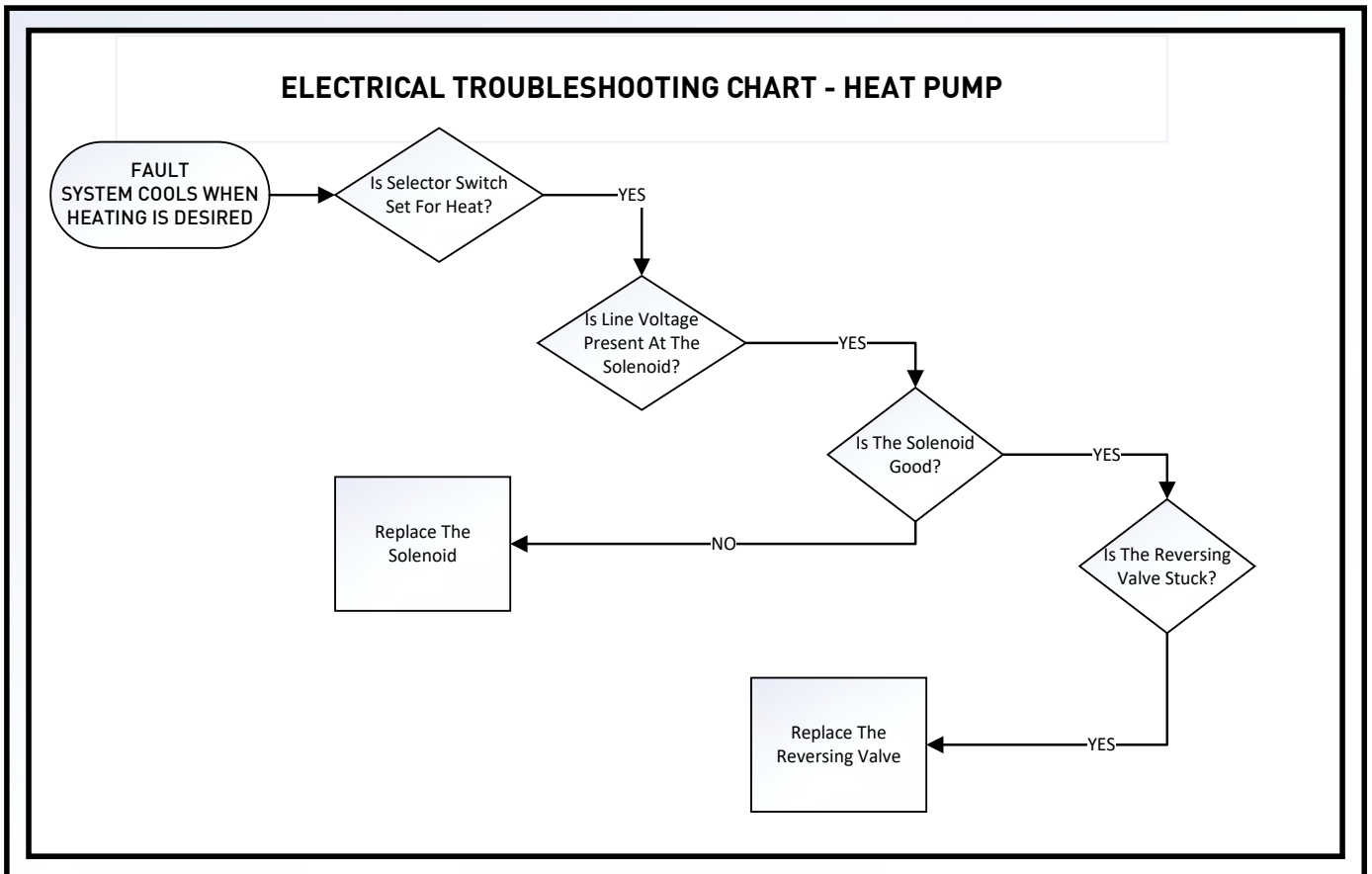
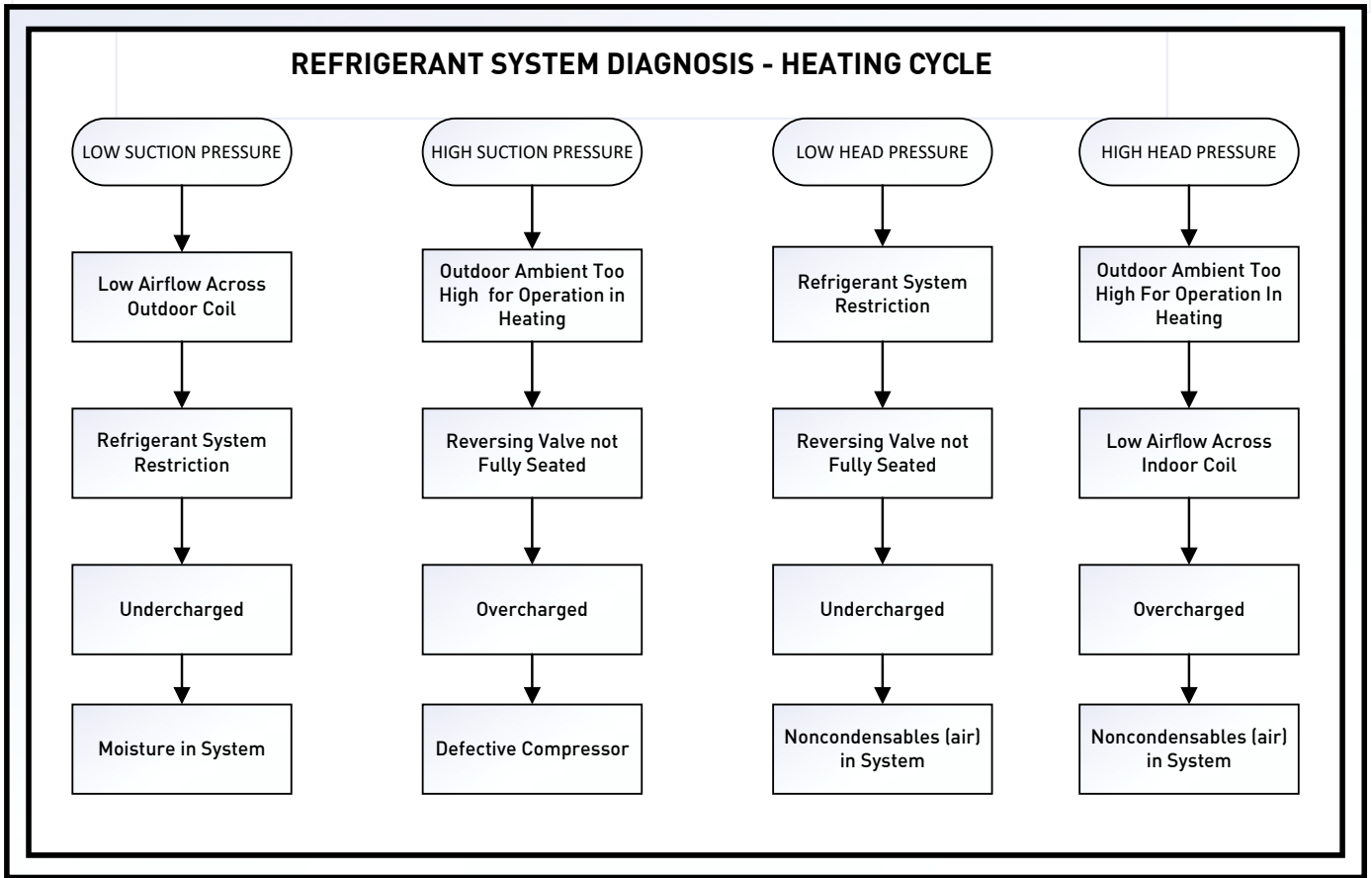

Figure 604 (Trouble Shooting Tips)

TROUBLESHOOTING

AIR CONDITIONERS: TROUBLE SHOOTING TIPS

REFRIGERANT SYSTEM DIAGNOSIS - COOLING CYCLE

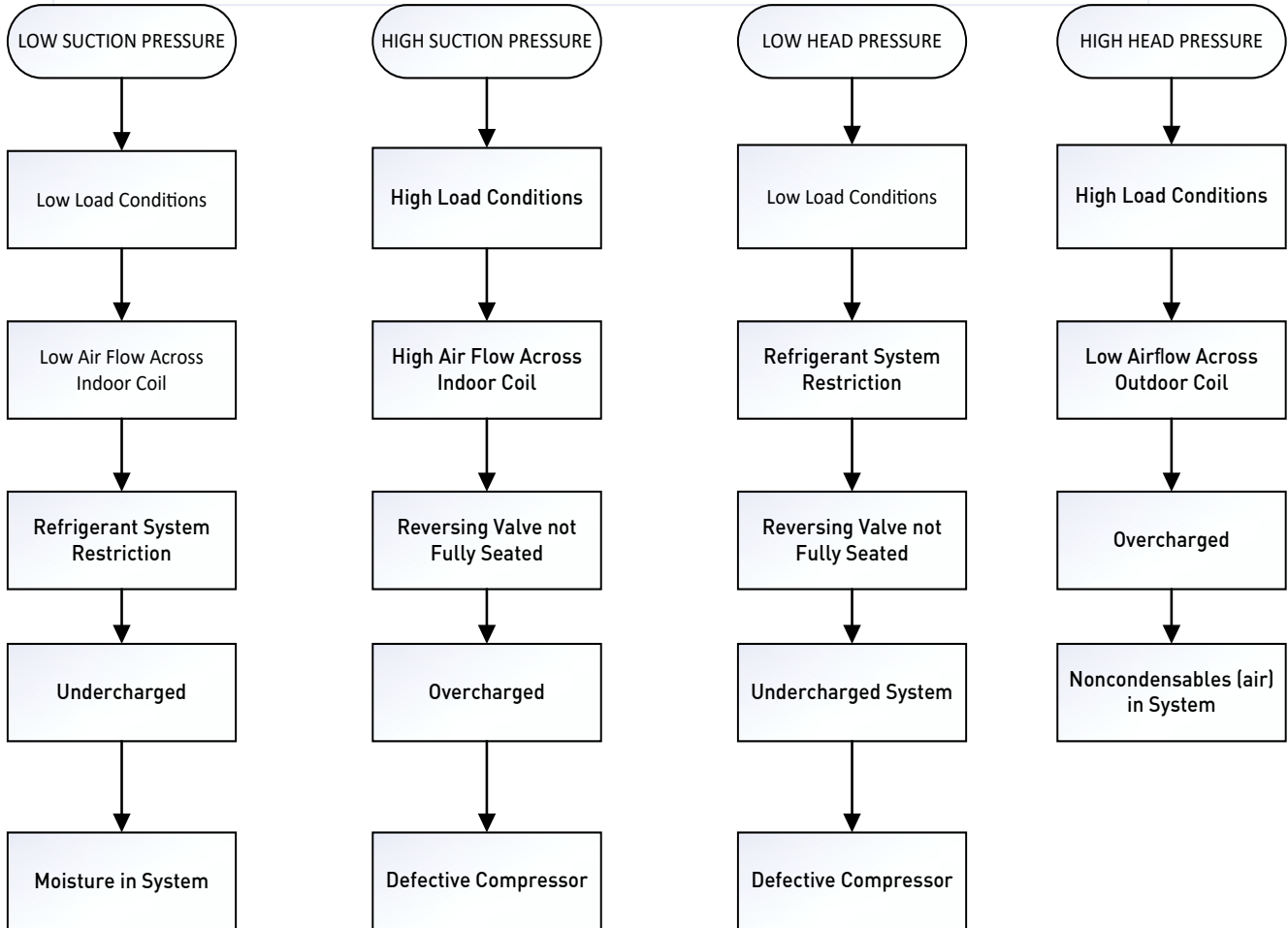



Figure 605 (Trouble Shooting Tips)

COMPONENT TESTING

Capillary Tube and Check Valve Assy (Heat Pump Units)

⚠ WARNING	
	BURN HAZARD Proper safety procedures must be followed, and proper protective clothing must be worn when working with a torch.
	Failure to follow these procedures could result in moderate or serious injury.

⚠ WARNING	
	CUT/SEVER HAZARD Be careful with the sharp edges and corners. Wear protective clothing and gloves, etc.
	Failure to do so could result in serious injury.

CHECK VALVE OPERATION

Check Valves

2 check valves are installed on Heat pump units. They are pressure operated and used to direct the flow of refrigerant to the proper capillary tube during either the heating or cooling cycle.

COOLING MODE

In the cooling mode of operation, high pressure liquid enters the check valve forcing the slide to close the opposite port (liquid line) to the indoor coil. Refer to figure 701. This directs the refrigerant through the cooling capillary tube to the indoor coil.

HEATING MODE

In the heating mode of operation, high pressure refrigerant enters the check valve from the opposite direction, closing the port (liquid line) to the outdoor coil. The flow path of the refrigerant is then through the heating capillary to the outdoor coil.

Failure of the slide in the check valve to seat properly in either mode of operation will cause flooding of the cooling coil. This is due to the refrigerant bypassing the heating or cooling capillary tube and entering the liquid line.

Test the Capillary Tube and Check Valve Assy

Allow unit to run for ten minutes before checking temps in order for unit to stabilize. Units tested at low ambient temps may frost momentarily, but will return to normal once unit pressure stabilizes. If frost does not stop after 10 minutes then a possible restriction or low refrigerant charge may be present.

1. Check the capillary tube temperature by hand where the refrigerant enters the capillary tube. A partial restriction of the capillary tube will be indicated by frost or freezing in that area.
2. If check valve fails closed or the capillary tube is fully restricted, then pressure will increase and pressure switch will open if installed. If no pressure switch is installed, the unit will shut down due to the compressor overload opening. High discharge temperature will be present at the compressor.
3. If check valve fails open the unit will continue to run, but there will be little to no cooling or heating.

In normal operation, the tube will be cooler on the side where the coolant is entering the cap tube then where it exits. If the check valve is stuck open, there will be little difference in temperature.

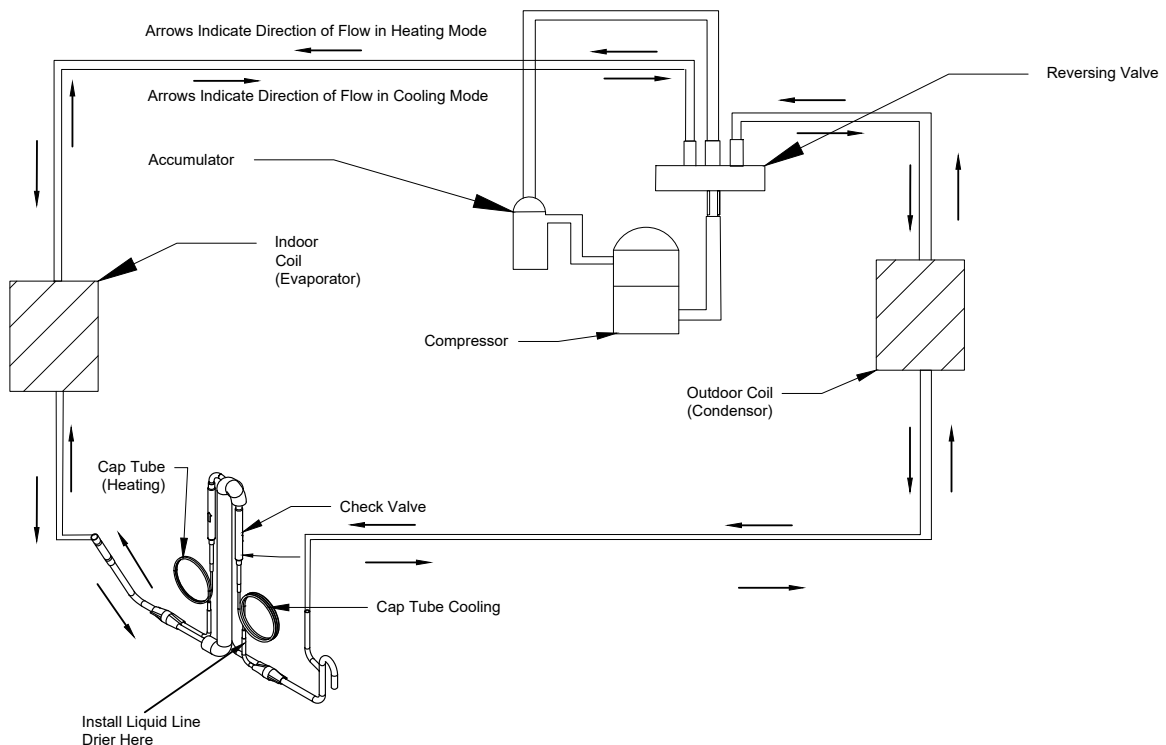

Figure 701 (Heat Pump Refrigerant Flow)

COMPONENT TESTING

Capillary Tube Assy (Cool Only Units)

Test the Capillary Tube and Check Valve Assy

1. Check the capillary tube temperature by hand where the refrigerant enters the capillary tube. A partial restriction of the capillary tube will be indicated by frost or freezing in that area.
2. If the capillary tube is fully restricted, then pressure will increase and pressure switch will open if installed. If no pressure switch is installed, the unit will shut down due to the compressor overload opening. High discharge temperature will be present at the compressor.

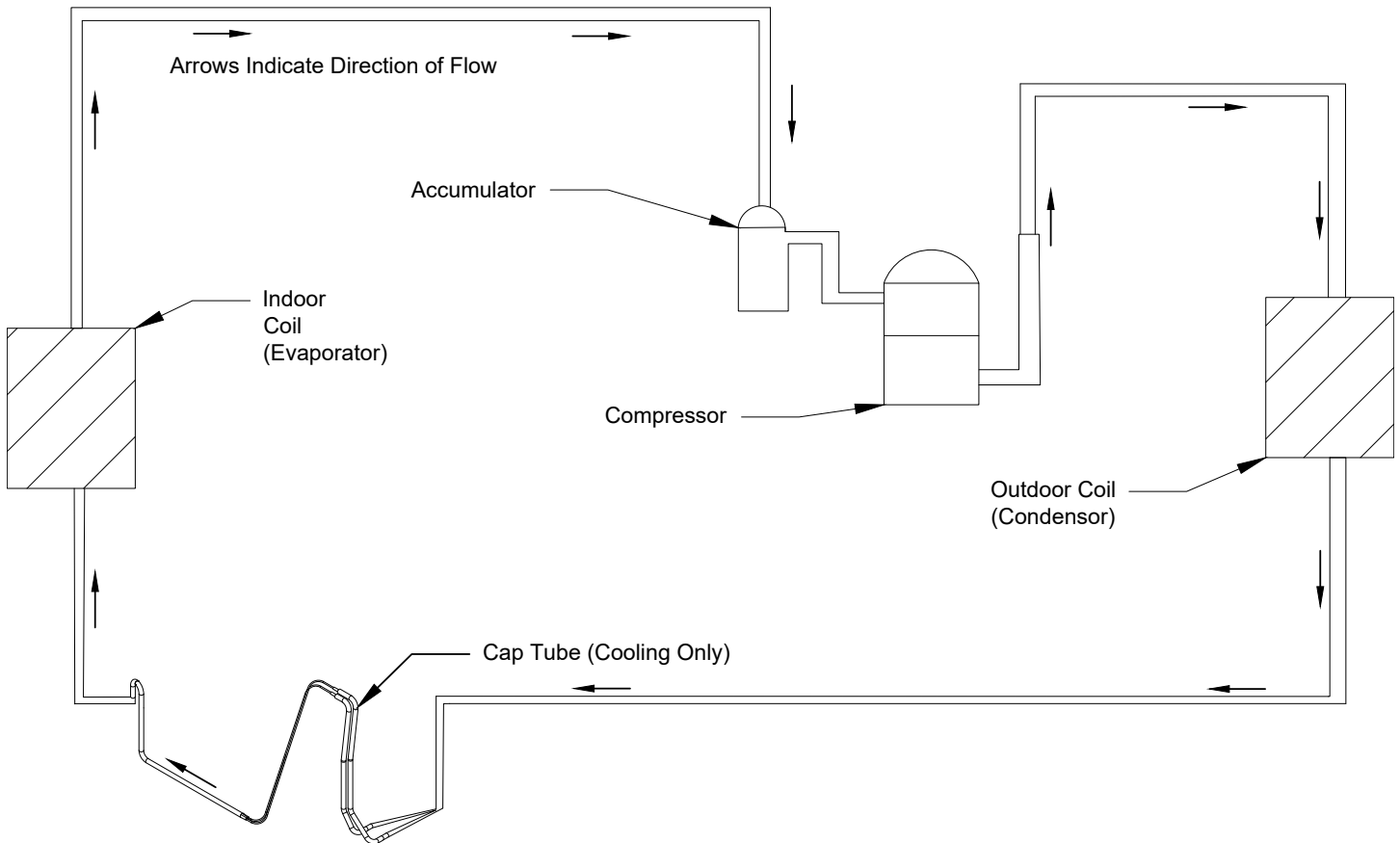

Figure 702 (Cooling Only Refrigerant Flow)

COMPONENT TESTING

Reversing Valve Description And Operation

The Reversing Valve controls the direction of refrigerant flow to the indoor and outdoor coils. It consists of a pressure-operated, main valve and a pilot valve actuated by a solenoid plunger. The solenoid is energized during the heating cycle only. The reversing valves used in the RAC system is a 2-position, 4-way valve.

The single tube on one side of the main valve body is the high-pressure inlet to the valve from the compressor. The center tube on the opposite side is connected to the low pressure (suction) side of the compressor. The other two are connected to the indoor and outdoor coils. Small capillary tubes connect each end of the main valve cylinder to the "A" and "B" ports of the pilot valve. A third capillary is a common return line from these ports to the suction tube on the main valve body. Four-way reversing valves also have a capillary tube from the compressor discharge tube to the pilot valve.

The piston assembly in the main valve can only be shifted by the pressure differential between the high and low sides of the system. The pilot section of the valve opens and closes ports for the small capillary tubes to the main valve to cause it to shift.

NOTE: System operating pressures must be near normal before valve can shift.

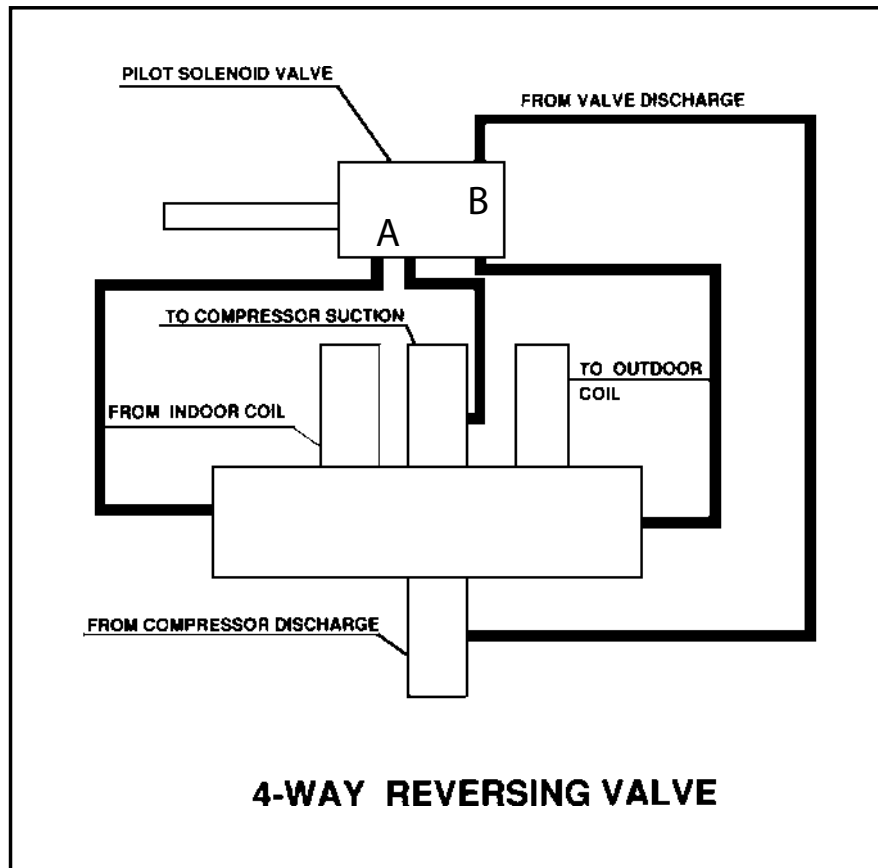
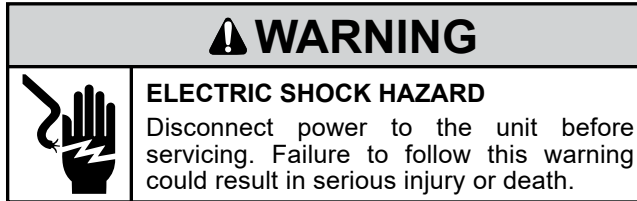

Figure 703 (Reversing Valve)

COMPONENT TESTING

Testing The Reversing Valve Solenoid Coil



The solenoid coil is an electromagnetic type coil mounted on the reversing valve and is energized during the operation of the compressor in the heating cycle.

1. Turn off high voltage electrical power to unit.
2. Unplug line voltage lead from reversing valve coil.
3. Check for electrical continuity through the coil. If you do not have continuity replace the coil.
4. Check from each lead of coil to the copper liquid line as it leaves the unit or the ground lug. There should be no continuity between either of the coil leads and ground; if there is, coil is grounded and must be replaced.
5. If coil tests okay, reconnect the electrical leads.
6. Make sure coil has been assembled correctly.

NOTE: Do not start unit with solenoid coil removed from valve, or do not remove coil after unit is in operation. This will cause the coil to burn out.

Touch Test in Heating/Cooling Cycle

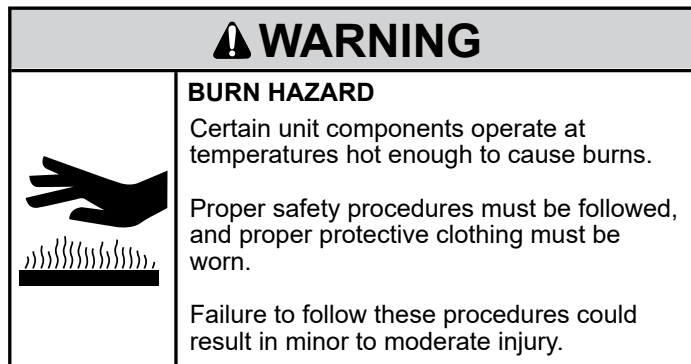

The only definite indications that the slide is in the mid-position is if all three tubes on the suction side of the valve are hot after a few minutes of running time.

NOTE: If both tubes shown as hot or cool are not the same corresponding temperature, refer to figure 704, then the reversing valve is not shifting properly.

COMPONENT TESTING

Checking The Reversing Valve

⚠ WARNING	
	HIGH PRESSURE HAZARD Sealed Refrigeration System contains refrigerant and oil under high pressure.
	Proper safety procedures must be followed, and PPE must be utilized when working with refrigerants.
	Failure to follow these procedures could result in serious injury or death.

NOTE: You must have normal operating pressures before the reversing valve can shift.

Check the operation of the valve by starting the system and switching the operation from “Cooling” to “Heating” and then back to “Cooling”. Do not hammer on valve.

Occasionally, the reversing valve may stick in the heating or cooling position or in the mid-position. When sluggish or stuck in the mid-position, part of the discharge gas from the compressor is directed back to the suction side, resulting in excessively high suction pressure.

Should the valve fail to shift from cooling to heating, block the air flow through the outdoor coil and allow the discharge pressure to build in the system. Then switch the system from heating to cooling.

If the valve is stuck in the heating position, block the air flow through the indoor coil and allow discharge pressure to build in the system. Then switch the system from heating to cooling.

Should the valve fail to shift in either position after increasing the discharge pressure, replace the valve.

Dented or damaged valve body or capillary tubes can prevent the main slide in the valve body from shifting. If you determine this is the problem, replace the reversing valve.

After all of the previous inspections and checks have been made and determined correct, then perform the “Touch Test” on the reversing valve.

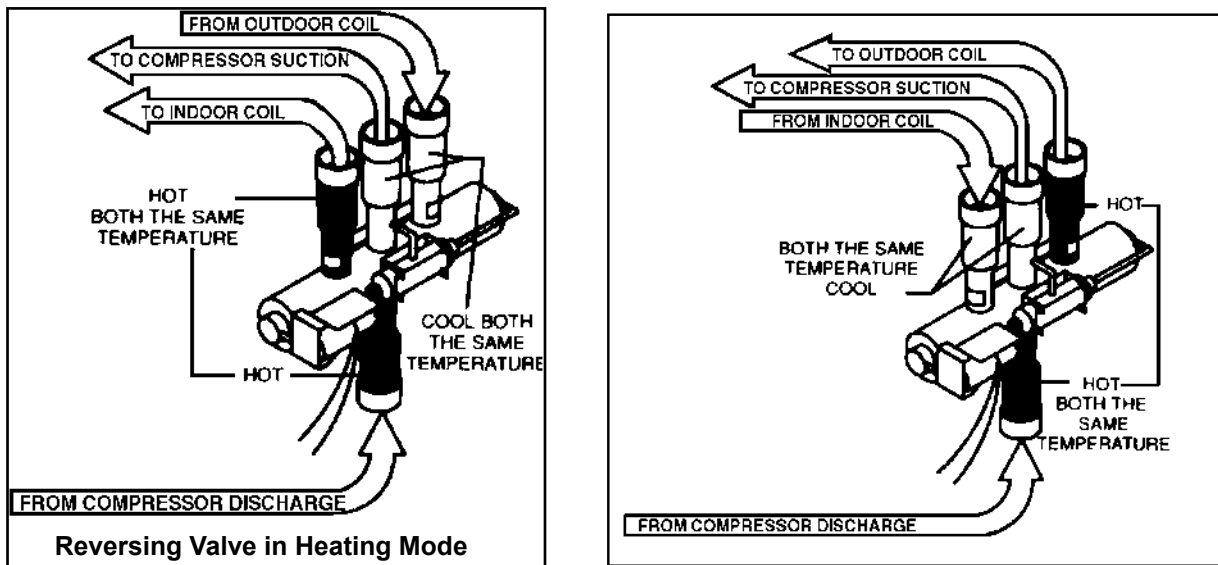

Figure 704 (Checking The Reversing Valve)

COMPONENT TESTING



Touch Test Chart : To Service Reversing Valves



NORMAL FUNCTION OF VALVE								
VALVE OPERATING CONDITION	DISCHARGE TUBE from Compressor	SUCTION TUBE	Tube to Indoor COIL	Tube to OUTSIDE COIL	LEFT Pilot	RIGHT Pilot	NOTES:	
							* TEMPERATURE OF VALVE BODY ** WARMER THAN VALVE BODY	
	1	2	3	4	5	6	POSSIBLE CAUSES	CORRECTIONS
Normal Cooling	Hot	Cool	Cool as (2)	Hot as (1)	*TVB	TVB		
Normal Heating	Hot	Cool	Hot as (1)	Cool as (2)	*TVB	TVB		
MALFUNCTION OF VALVE								
Valve will not shift from cool to heat.	Check Electrical circuit and coil						No voltage to coil.	Repair electrical circuit.
							Defective coil.	Replace coil.
	Check refrigeration charge						Low charge.	Repair leak, recharge system.
							Pressure differential too high.	Recheck system.
	Hot	Cool	Cool, as (2)	Hot, as (1)	*TVB	Hot	Pilot valve okay. Dirt in one bleeder hole.	Deenergize solenoid, raise head pressure, reenergize solenoid to break dirt loose. If unsuccessful, remove valve, wash out. Check on air before installing. If no movement, replace valve, add strainer to discharge tube, mount valve horizontally.
							Piston cup leak	Stop unit. After pressures equalize, restart with solenoid energized. If valve shifts, reattempt with compressor running. If still no shift, replace valve.
Valve will not shift from cool to heat.	Hot	Cool	Cool, as (2)	Hot, as (1)	*TVB	*TVB	Clogged pilot tubes.	Raise head pressure, operate solenoid to free. If still no shift, replace valve.
	Hot	Cool	Cool, as (2)	Hot, as (1)	Hot	Hot	Both ports of pilot open. (Back seat port did not close).	Raise head pressure, operate solenoid to free partially clogged port. If still no shift, replace valve.
	Warm	Cool	Cool, as (2)	Hot, as (1)	*TVB	Warm	Defective Compressor.	Replace compressor
Starts to shift but does not complete reversal.	Hot	Warm	Warm	Hot	*TVB	Hot	Not enough pressure differential at start of stroke or not enough flow to maintain pressure differential.	Check unit for correct operating pressures and charge. Raise head pressure. If no shift, use valve with smaller port.
							Body damage.	Replace valve
	Hot	Warm	Warm	Hot	Hot	Hot	Both ports of pilot open.	Raise head pressure, operate solenoid. If no shift, use valve with smaller ports.
	Hot	Hot	Hot	Hot	*TVB	Hot	Body damage.	Replace valve
							Valve hung up at mid-stroke. Pumping volume of compressor not sufficient to maintain reversal.	Raise head pressure, operate solenoid. If no shift, use valve with smaller ports.
Apparent leap in heating.	Hot	Hot	Hot	Hot	Hot	Hot	Both ports of pilot open.	Raise head pressure, operate solenoid. If no shift, replace valve.
	Hot	Cool	Hot, as (1)	Cool, as (2)	*TVB	*TVB	Piston needle on end of slide leaking.	Operate valve several times, then recheck. If excessive leak, replace valve.
	Hot	Cool	Hot, as (1)	Cool, as (2)	**WVB	**WVB	Pilot needle and piston needle leaking.	Operate valve several times, then recheck. If excessive leak, replace valve.
	Hot	Cool	Hot, as (1)	Cool, as (2)	*TVB	*TVB	Pressure differential too high.	Stop unit. Will reverse during equalization period. Recheck system
Will not shift from heat to cool.							Clogged pilot tube.	Raise head pressure, operate solenoid to free dirt. If still no shift, replace valve.
	Hot	Cool	Hot, as (1)	Cool, as (2)	Hot	*TVB	Dirt in bleeder hole.	Raise head pressure, operate solenoid. Remove valve and wash out. Check on air before reinstalling, if no movement, replace valve. Add strainer to discharge tube. Mount valve horizontally.
	Hot	Cool	Hot, as (1)	Cool, as (2)	Hot	*TVB	Piston cup leak.	Stop unit. After pressures equalize, restart with solenoid deenergized. If valve shifts, reattempt with compressor running. If it still will not reverse while running, replace the valve.
	Hot	Cool	Hot, as (1)	Cool, as (2)	Hot	Hot	Defective pilot.	Replace valve.
	Warm	Cool	Warm, as (1)	Cool, as (2)	Warm	*TVB	Defective compressor.	Replace compressor

Figure 705 (Touch Test Chart)

COMPONENT TESTING

Compressor Checks

 WARNING	
	ELECTRIC SHOCK HAZARD Turn off electric power before service or installation. All electrical connections and wiring MUST be installed by a qualified electrician and conform to the National Electrical Code and all local codes which have jurisdiction. Failure to do so can result in personal injury or death.

 WARNING	
	BURN HAZARD Proper safety procedures must be followed, and proper protective clothing must be worn when working with a torch. Failure to follow these procedures could result in moderate or serious injury.

Single Phase Running and L.R.A. Test

NOTE: The L.R.A. can be found on the rating plate.

Select the proper amperage scale and clamp the meter probe around the wire to the “C” terminal of the compressor.

Turn on the unit and read the running amperage on the meter. If the compressor does not start, the reading will indicate the locked rotor amperage (L.R.A.).

Overloads

The compressor is equipped with either an external or internal overload which senses both motor amperage and winding temperature. High motor temperature or amperage heats the overload causing it to open, breaking the common circuit within the compressor. Heat generated within the compressor shell, usually due to recycling of the motor, is slow to dissipate. It may take anywhere from a few minutes to several hours for the overload to reset.

Checking the Overloads

CAUTION: Before attempting to check overloads, ensure that compressor is cool to touch.

External Overloads

With power off, remove the leads from compressor terminals. If the compressor is hot, allow the overload to cool before starting check. Using an ohmmeter, test continuity across the terminals of the external overload. If you do not have continuity; this indicates that the overload is open and must be replaced.

Internal Overloads

Some model compressors are equipped with an internal overload. The overload is embedded in the motor windings to sense the winding temperature and/or current draw. The overload is connected in series with the common motor terminal.

Should the internal temperature and/or current draw become excessive, the contacts in the overload will open, turning off the compressor. The overload will automatically reset, but may require several hours before the heat is dissipated.

Checking the Internal Overload

1. With no power to unit, remove the leads from the compressor terminals.
2. Using an ohmmeter, test continuity between terminals C-S and C-R. If no continuity, and the compressor is not hot to the touch, the compressor overload is open, and the compressor should be replaced.

COMPONENT TESTING

Compressor Checks

⚠ WARNING	
	<p>ELECTRIC SHOCK HAZARD Turn off electric power before service or installation. Extreme care must be used, if it becomes necessary to work on equipment with power applied.</p> <p>Failure to do so could result in serious injury or death.</p>

⚠ WARNING	
	<p>HIGH PRESSURE HAZARD Sealed Refrigeration System contains refrigerant and oil under high pressure.</p> <p>Proper safety procedures must be followed, and PPE must be utilized when working with refrigerants.</p> <p>Failure to follow these procedures could result in serious injury or death.</p>

Single Phase Resistance Test

Remove the leads from the compressor terminals and set the ohmmeter on the lowest scale (R x 1).

Touch the leads of the ohmmeter from terminals common to start ("C" to "S"). Next, touch the leads of the ohmmeter from terminals common to run ("C" to "R").

Add values "C" to "S" and "C" to "R" together and check resistance from start to run terminals ("S" to "R"). Resistance "S" to "R" should equal the total of "C" to "S" and "C" to "R."

In a single phase PSC compressor motor, the highest value will be from the start to the run connections ("S" to "R"). The next highest resistance is from the start to the common connections ("S" to "C"). The lowest resistance is from the run to common. ("C" to "R") Before replacing a compressor, check to be sure it is defective.

GROUND TEST

Use an ohmmeter set on its highest scale. Touch one lead to the compressor body (clean point of contact as a good connection is a must) and the other probe in turn to each compressor terminal. If a reading is obtained the compressor is grounded and must be replaced.

Check the complete electrical system to the compressor and compressor internal electrical system, check to be certain that compressor is not out on internal overload.

Complete evaluation of the system must be made whenever you suspect the compressor is defective. If the compressor has been operating for sometime, a careful examination must be made to determine why the compressor failed.

Many compressor failures are caused by the following conditions:

1. Improper air flow over the evaporator.
2. Overcharged refrigerant system causing liquid to be returned to the compressor.
3. Restricted refrigerant system.
4. Lack of lubrication.
5. Liquid refrigerant returning to compressor causing oil to be washed out of bearings.
6. Non-condensables such as air and moisture in the system. Moisture is extremely destructive to a refrigerant system.
7. Capacitor.

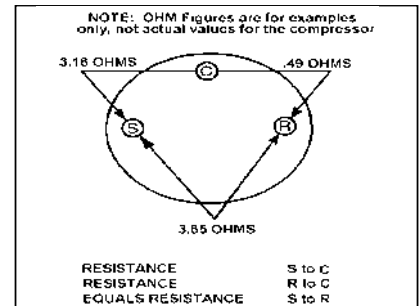



Figure 706 (Resistance Chart)

COMPONENTS TESTING

Fan Motor

The Fan Motor installed in your Kuhl or Wallmaster unit is a dual shaft motor driving both the condenser fan and the indoor blower wheel. Depending on the unit either a PSC or an ECM type motor will be installed. The testing procedure for both is the same. The procedure for checking a 115 vac motor is also the same as checking a 230 vac motor.

1. Unplug the unit.
2. Remove front cover. [Refer to Routine Maintenance.](#)

⚠ WARNING	
	ELECTRIC SHOCK HAZARD Turn off electric power before service or installation. Extreme care must be used, if it becomes necessary to work on equipment with power applied.
	Failure to do so could result in serious injury or death.

3. Access Control Panel.
 - a. For Kuhl Units refer to [Kuhl Control board replacement.](#)
 - b. For Kuhl Q Units refer to [Kuhl Q Control Panel Replacement.](#)
 - c. For Wallmaster units refer to [Wallmaster Control Board Replacement.](#)
4. Open control box to gain access to board.
5. On Kuhl Q models remove display board from front panel and the plug back in. Refer to Figure 707.

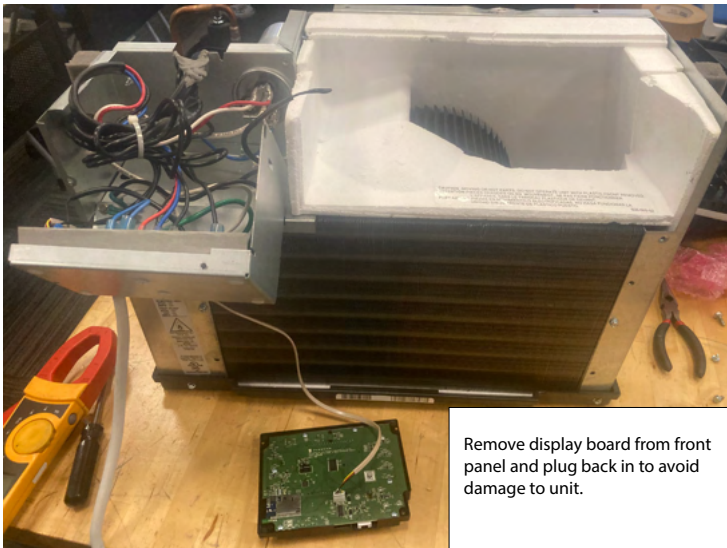

Figure 707

6. Plug unit in.

7. Set multi meter to check for 115/230 vac.
8. Place black probe on N/L2 terminal.
9. Place red probe on speed relay.
 - a. To check hi speed check power on relay with black wire.
 - b. To check medium speed check power on relay with blue wire.
 - c. To check low speed check power on relay with red wire.

Refer to Figure 708.

If Power is available at corresponding fan speeds but fan motor does run, replace the fan motor.

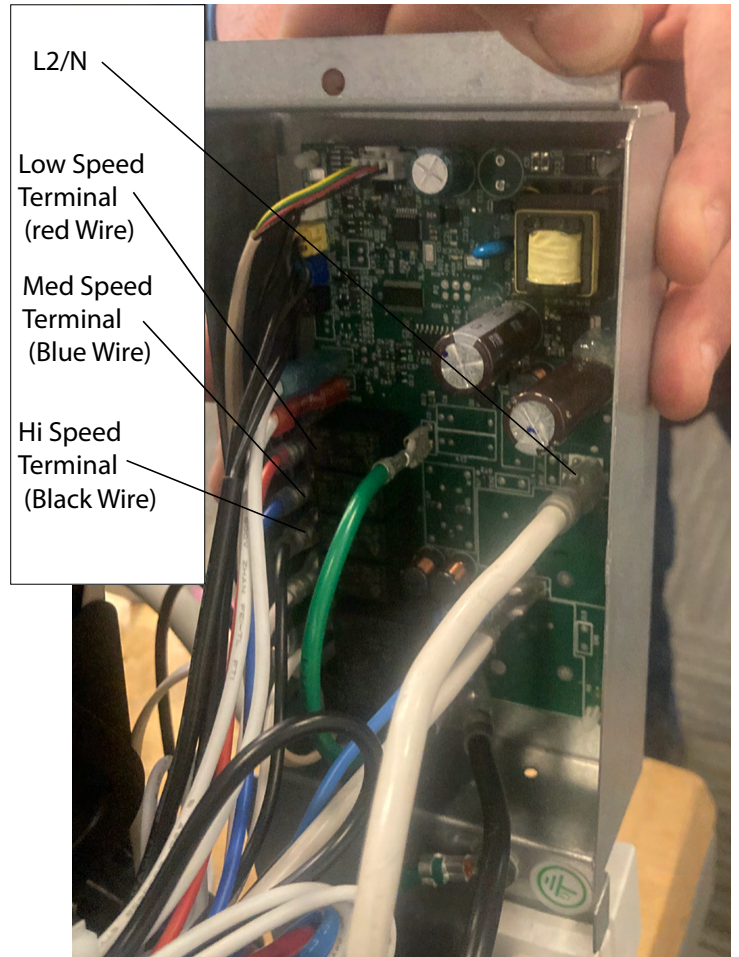



Figure 708

COMPONENTS TESTING

Checking Capacitors

⚠ WARNING	
	<p>ELECTRIC SHOCK HAZARD Turn off electric power before service or installation. Extreme care must be used, if it becomes necessary to work on equipment with power applied.</p> <p>Failure to do so could result in serious injury or death.</p>

Many motor capacitors are internally fused. Shorting the terminals will blow the fuse, ruining the capacitor. A 20,000 ohm 2 watt resistor can be used to discharge capacitors safely. Remove wires from capacitor and place resistor across terminals. When checking a dual capacitor with a capacitor analyzer or ohmmeter, both sides must be tested.

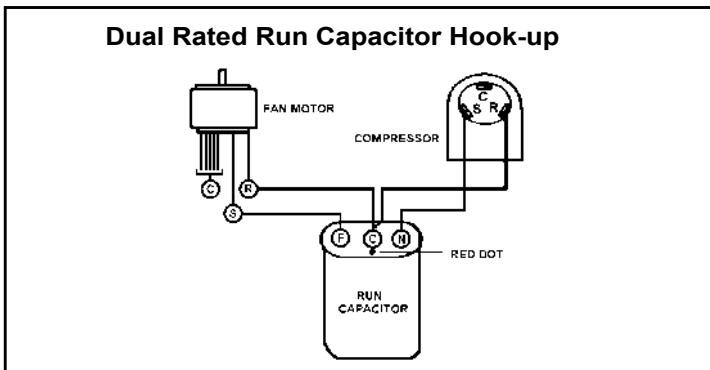

Figure 709

Dual Capacitor Check The meter will show whether the capacitor is “open” or “shorted.” It will tell whether the capacitor is within its micro farads rating and it will show whether the capacitor is operating at the proper power-factor percentage.

1. Set the settings on multi meter to microfarads (uF).
2. Connect the black to common terminal on the capacitor.
3. Connect the red probe to the herm connection (to check compressor circuit) or fan connection (to check fan circuit) of the capacitor. Read the value and compare to the rating on the capacitor.
4. If reading deviates from rating by more than 6% replace the capacitor.

COMPONENTS TESTING

⚠ WARNING



ELECTRIC SHOCK HAZARD

Turn off electric power before service or installation. Extreme care must be used, if it becomes necessary to work on equipment with power applied.

Failure to do so could result in serious injury or death.

Thermistors Description

The units have 4 sensors (Thermistors). Each thermistor is color coded and has a different function.

1. Indoor Coil (Yellow) - located on the evaporator coil next to the power board.
2. Outdoor Coil (Blue) - located on the condenser coil.
3. Discharge Air (Black) - located on the front of the unit in the discharge air port.
4. Ambient Air (White) - located on the front of the unit in front of the air intake.

Thermistor Testing

1. Gain access to Electronic Control Board (Refer to Control Board Replacement.
[For Kuhl](#)
[For Kuhl Q](#)
[For Wallmaster](#)
2. Locate thermistor plug and disconnect from Control Board. (Refer to Control Board Identification, Fig 711)
3. Check for proper resistance. ([Refer to Thermistor Resistance values](#)).
4. If thermistor is out of tolerance, replace thermistor.

Replace Solid State Relay

Model **KCL36B30A** are equipped with a solid state relay to handle the higher current demands of these units. The relay is located on the inside of the Control Mounting Panel in between the Control Board and Power Cord.

- 1) Unplug the unit.
- 2) Remove wire ties as necessary for slack in electrical wiring.
- 3) Remove 3 screws from Control Mounting Panel.
- 4) Carefully pull out panel and you will have access to replace Capacitor or SSR.
- 5) Replace Component as necessary.
- 6) Ensure all electrical connections are correct.
- 7) Reinstall Control Mounting Panel
- 8) Secure wiring as necessary.
- 9) Plug unit back in.
- 10) Test Unit to ensure problems are corrected.

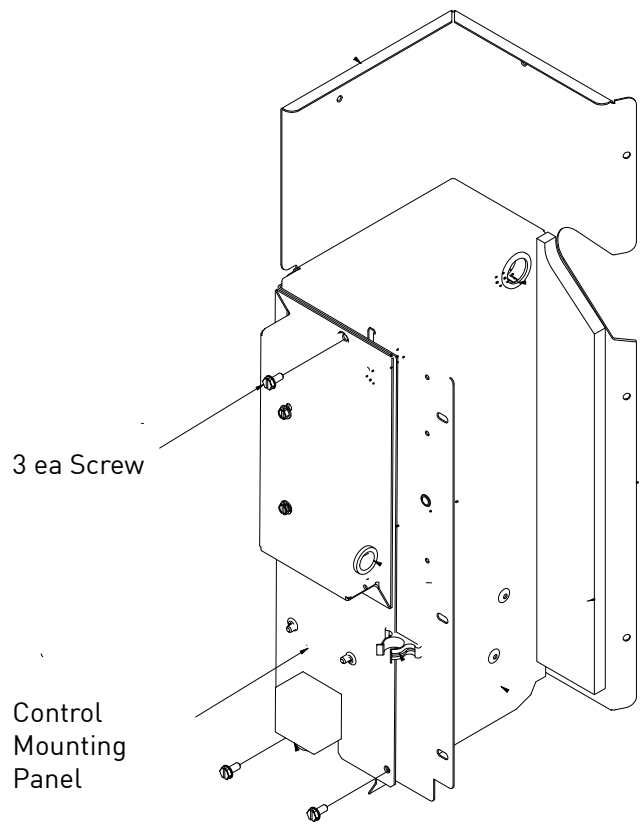

Figure 710 (Access to SSR or Capacitor)

COMPONENTS TESTING

Test User Interface and Electronic Control Board

If the User Interface does not turn on:

1. Make sure the unit has the proper voltage and that it is turned on. Check power at Terminals L1 and L2. (Refer to Electronic Control Board Identification, Figure 711)
2. Disconnect the User Interface's wire harness on the control board.
3. Using a voltmeter, check the outer pins on the user interface port of the electronic control board. There should be 24VDC. (Refer to Electronic Control Board Identification, Fig 711)
4. If there is no voltage, replace the electronic control board.

5. If 24 VDC is present replace the User Interface and/ or the ribbon cable.

- [For Kuhl](#)
- [For Kuhl Q](#)
- [For Wallmaster](#)

Electronic Control Board Identification

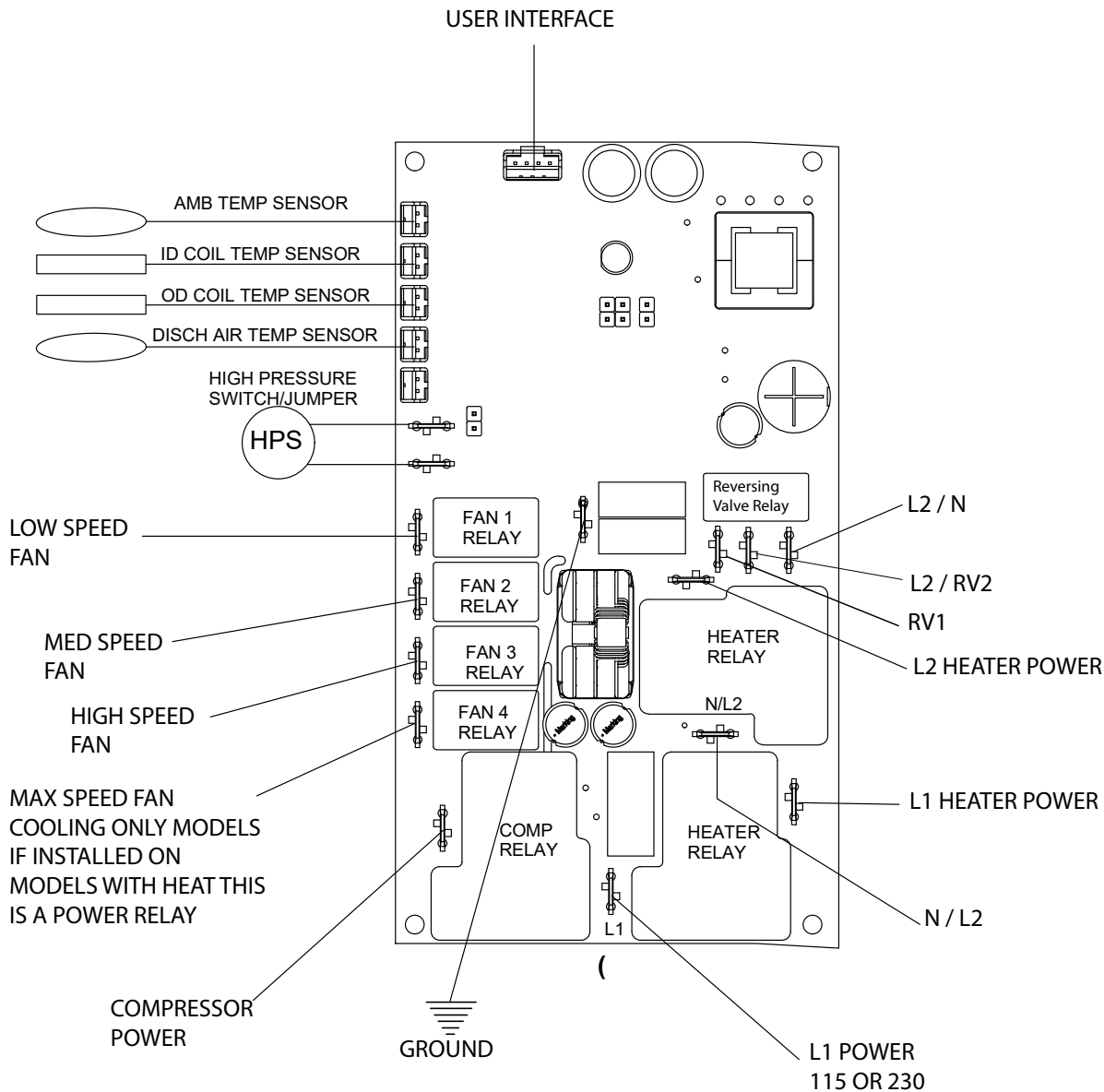



Figure 711 (Electronic Control Board Identification)

COMPONENT TESTING

Replace the Electronic Control Board- Kuhl

1.

⚠ WARNING	
	ELECTRIC SHOCK HAZARD Turn off electric power before service or installation. Extreme care must be used, if it becomes necessary to work on equipment with power applied.
	Failure to do so could result in serious injury or death.

Unplug the unit

2. Remove the Front Cover. [Refer to Routine Maintenance, Figure 401.](#)

3. Remove three (3) screws from Control Box Panel .

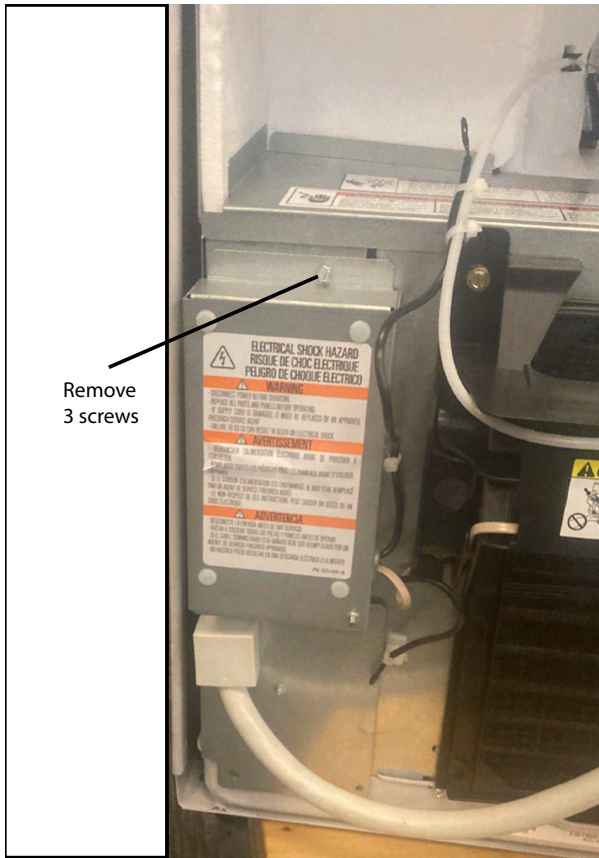

Figure 712

4. If necessary, cut wire ties and remove one(1) screw from electronic holder to create slack in wiring. Refer to figure 712.

5. Swap wires one for one from old control board to new control board. If swapping wires one for one is not possible, identify and tag wires. Refer to figure 713.

6 . Remove the four(4) circuit Board pins using needle nose pliers or other suitable tool. Refer to figure 714.

7. If Jumper is installed on High pressure switch terminals, Swap jumper from old control board to new control board.

8. Install the control board using four(4) new circuit board pins.

9. Install fish paper as insulation between control board and metal. Secure with the circuit board pins.

10. Reinstall the control board panel, reinstall the screw in the electronic holder, and secure wiring as required.

11. Install the Front Cover. ([Refer to Routine Maintenance, Figure 401.](#))



Figure 713



Figure 714

12. Plug in the unit and test the unit for proper operation. Refer to operation section.

Replace the User Interface

1. Unplug the Unit

[Remove the Front Cover. Refer to Routine Maintenance, Figure 401.](#)

2. Remove 2 -mounting screws securing UI and disconnect ribbon cable.

3. Inspect ribbon cable for obvious signs of damage.

4. If ribbon cable is damaged, or damage is suspected, disconnect cable from User Interface and Control Board.

5. Paying careful attention to the ribbon cable routing, remove the old cable and replace with a new ribbon cable.

5. Connect ribbon cable to the power board and user interface as required.

6. Install new UI using the 2-screws.

7. Plug in the unit and verify control operation. Refer to Operation Section.

COMPONENTS TESTING

Replace the Electronic Control Board- Kuhl Q

⚠ WARNING	
	ELECTRIC SHOCK HAZARD Turn off electric power before service or installation. Extreme care must be used, if it becomes necessary to work on equipment with power applied.
	Failure to do so could result in serious injury or death.

1. Unplug the unit
 2. Remove the front Cover [\[Refer to Routine Maintenance, Figure 402\]](#)
 3. Remove the unit from the sleeve. [\[Refer to Figure 504\]](#)
 4. Remove top cover (8 screws). Refer to figure 715.
- NOTE:** Be careful not to break styrofoam during removal process.

6. Interchange wires from old circuit board to new circuit board
7. Remove the four (4) circuit Board pins using needle nose pliers or other suitable tool.
7. Install the new control board using four(4) new circuit board pins.
8. Reinstall the control board panel, secure wiring as required.
9. Reinstall the discharge sensor and grommet.
10. Slide chassis in.
11. Install the Front Cover [\[Refer to Routine Maintenance, Figure 402\]](#)
12. Plug in the unit and test the unit for proper operation. Refer to operation section.

Replace the User Interface

1. Unplug the Unit.
2. Remove the front Cover [\[Refer to Routine Maintenance, Figure 402\]](#)
3. Remove the 4 corner screws from the rear of the user interface. Refer to Figure 717.



Figure 715 (Remove Top Cover)

4. Remove the discharge sensor and grommet. (Take note of the routing for reinstallation).
5. If necessary, cut wire ties and remove one (1) screw electronic holder to create slack in wiring. Refer to Figure 715.

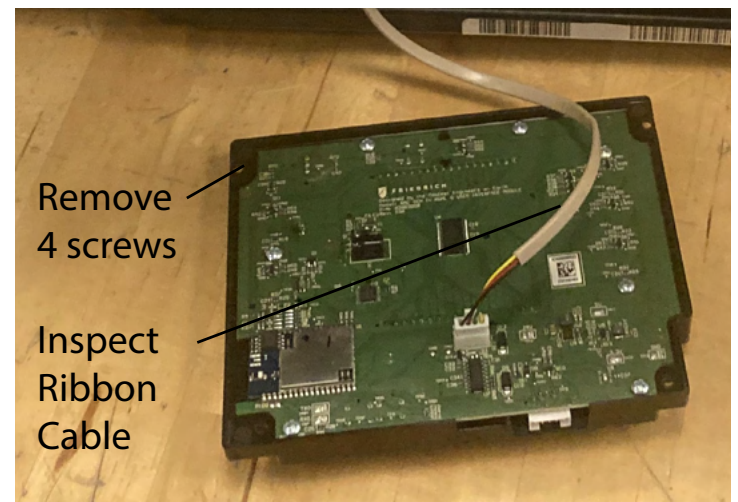

Figure 717

4. Inspect ribbon cable for obvious signs of damage.
5. If ribbon cable is damaged, or damage is suspected, disconnect cable from User Interface and Control Board.
6. Paying careful attention to the ribbon cable routing, remove the old cable and replace with a new ribbon cable.
7. Connect ribbon cable to the power board and user interface as required.
8. Install new UI using the 4 screws.
9. Plug in the unit and verify control operation. (Refer to Operation Section)

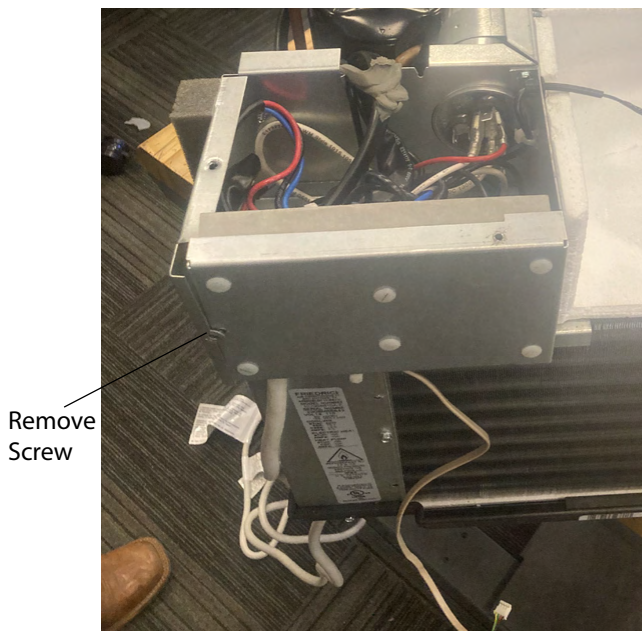



Figure 716 (Open Control Box)

COMPONENT TESTING

Replace the User Interface - Wallmaster

⚠ WARNING	
	ELECTRIC SHOCK HAZARD Turn off electric power before service or installation. Extreme care must be used, if it becomes necessary to work on equipment with power applied. Failure to do so could result in serious injury or death.

1. Unplug the Unit
2. Remove the Front Cover. [Refer to Routine Maintenance, Figure 403.](#)
3. Slide the unit out approximately 3 inches from the sleeve. [Refer to figure 506 for chassis removal.](#)
4. Using a sharp knife, cut slits in the Chassis gasket seal where the control board panel will be opened to avoid damaging the gasket.
5. Remove two (2) screws from the top, and one (1) from the front of the control board panel and open panel.
6. Remove two (2) mounting screws securing UI and disconnect ribbon cable.

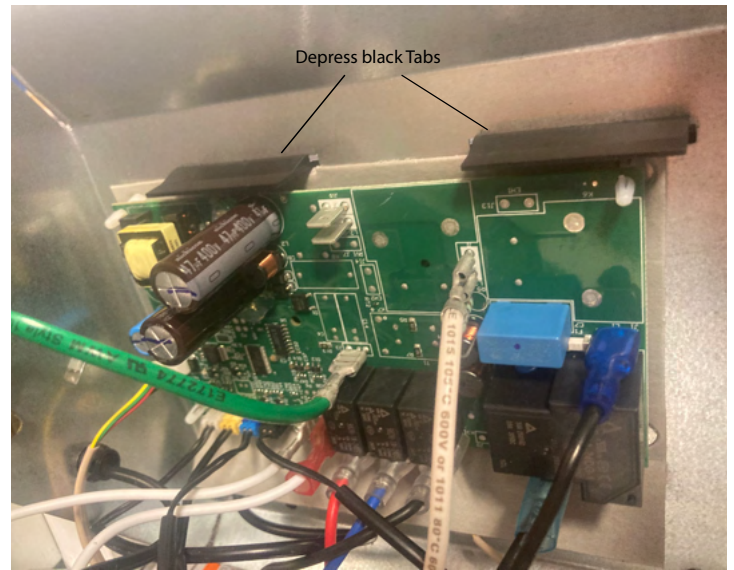

Figure 719

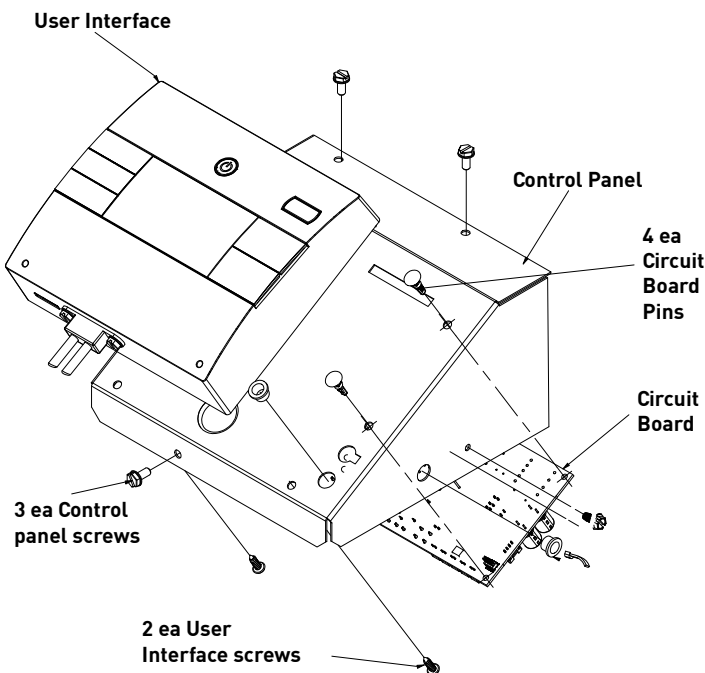



Figure 718

7. Carefully depress 2 black tabs by squeezing towards the bottom of the interface you. Refer to Figure 718. Inspect ribbon cable for obvious signs of damage.
8. If ribbon cable is damaged, or damage is suspected, disconnect cable from User Interface and Control Board.
9. Paying careful attention to the ribbon cable routing, remove the old cable and replace with a new ribbon cable.
10. Connect ribbon cable to the power board and user interface as required.
11. Install new UI using the 2 screws.
12. Install the 3 Control Panel Screws.
13. Plug in the unit and verify control operation. Refer to Operation Section.

COMPONENT TESTING

Replace the Electronic Control Board - Wallmaster

⚠ WARNING	
	ELECTRIC SHOCK HAZARD
	Turn off electric power before service or installation. Extreme care must be used, if it becomes necessary to work on equipment with power applied.
	Failure to do so could result in serious injury or death.

1. Unplug the unit
2. Remove the Front Cover. [Refer to Routine Maintenance, Figure 403.](#)
3. Slide the unit out approximately 3 inches from the sleeve. [Refer to figure 506 for chassis removal.](#)
4. Using a sharp knife, cut slits in the Chassis gasket seal where the control board panel will be opened to avoid damaging the gasket.
5. Remove two (2) screws from the top, and one (1) from the front of the control board panel and open panel.
5. Remove the four(4) circuit Board pins using needle nose pliers or other suitable tool.

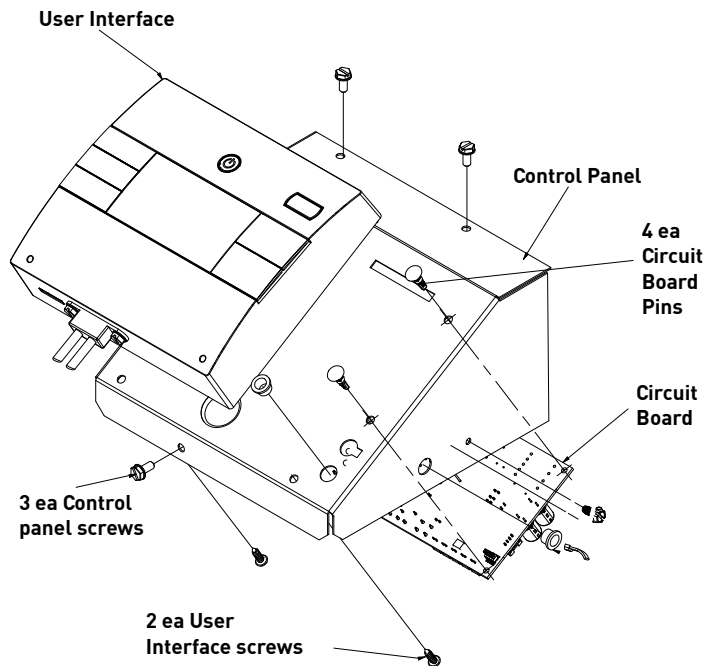

Figure 720

6. Swap wires one for one from old control board to new control board. If swapping wires one for one is not possible, identify and tag wires. Refer to the wiring diagrams as required.
7. Install the control board using four(4) new circuit board pins. Remove User Interface to gain access to the pins. Refer to Figure 720
8. Reinstall the control board panel, with three (3) screws reinstall the screw in the electronic holder, and secure wiring as required.
9. Install the Front Cover ([refer to Routine Maintenance](#)).
10. Plug in the unit and test the unit for proper operation. Refer to operation section.



Figure 721

R-32 SEALED SYSTEM REPAIR

General Information

WARNING: Electrical Shock Hazard

Disconnect all power to the unit before starting maintenance. All electrical connections and wiring **MUST** be installed by a qualified electrician and conform to all codes which have jurisdiction. Failure to do so can result in property damage, severe electrical shock or death.



WARNING: This Product uses R-32 Refrigerant

Do not use means to accelerate the defrosting process or to clean, other than those recommended by the manufacturer.

When not installed, the appliance shall be stored in a room without continuously operating ignition sources (for example: open flames, an operating gas appliance or an operating electric heater).

Do not pierce or burn.

Be aware that refrigerants may not contain an odor.



**Refrigerant
Safety Group
A2L**

WARNING: Refrigeration System under High pressure

Do not puncture, heat, expose to flame or incinerate. Only certified refrigeration technicians should service this equipment. R32 systems operate at higher pressures than R22 equipment. Appropriate safe service and handling practices must be used.





 **Warning:** Prior to beginning work on systems containing FLAMMABLE REFRIGERANTS, safety checks are necessary to ensure that the risk of ignition is minimized.

NOTICE: Individuals working on these units must be EPA 608 Certified along with A2L Refrigerant Training.

 **Warning:** Refrigerant 32 cannot be used as a retrofit for R-410A refrigerant. The mixing of refrigerant across classes is prohibited. R-32 is not a drop in replacement for R-410A.

General Work Area: All maintenance staff and others working in the installation area shall be instructed on the nature of work being carried out. Work in confined spaces as defined by the Occupational Safety And Health Administration shall be avoided.

 **Warning:** Job site should be examined for safety hazards such as flammable vapors, ignition sources, ventilation and confined spaces. Create a safe perimeter with barriers and signs designating a flammable area.

 **Warning:** Work shall be undertaken under a controlled procedure so as to minimise the risk of a flammable gas or vapor being present while the work is being performed.

Check for presence of refrigerant:

- The area shall be checked with an appropriate refrigerant detector prior to and during work, to ensure the technician is aware of potentially toxic or flammable atmospheres.
- Ensure that the leak detection equipment being used is suitable for use with all applicable refrigerants, i.e. non-sparking, adequately sealed or intrinsically safe.
- Under no circumstances shall potential sources of ignition be used in the searching for or detection of refrigerant leaks. A halide torch (or any other detector using a naked flame) shall not be used.
- The following leak detection methods are deemed acceptable for all refrigerant systems:
 1. Electronic leak detectors may be used to detect refrigerant leaks but, in the case of FLAMMABLE REFRIGERANTS, the sensitivity may not be adequate, or may need re-calibration. (Detection equipment shall be calibrated in a refrigerant-free area.) Ensure that the detector is not a potential source of ignition and is suitable for the refrigerant used.
 2. Leak detection fluids are also suitable for use with most refrigerants but the use of detergents containing chlorine shall be avoided as the chlorine may react with the refrigerant and corrode the copper pipe-work.If a leak is suspected, all flame sources shall be removed/extinguished.

Presence of fire extinguisher: If any hot work is to be conducted on the refrigerating equipment or any associated parts, a class ABC Rated fire extinguishing equipment shall be available to hand. Have a class ABC Rated fire extinguisher adjacent to the charging area.

R-32 SEALED SYSTEM REPAIR

General Information

Warning:

No ignition sources: No person carrying out work in relation to a REFRIGERATING SYSTEM which involves exposing any pipe work shall use any sources of ignition in such a manner that it may lead to the risk of fire or explosion. All possible ignition sources, including cigarette smoking, should be kept sufficiently far away from the site of installation, repairing, removing and disposal, during which refrigerant can possibly be released to the surrounding space. Prior to work taking place, the area around the equipment is to be surveyed to make sure that there are no flammable hazards or ignition risks.

Ventilated Area: Ensure that the area is in the open or that it is adequately ventilated before accessing the refrigerant in the system or conducting any hot work. A degree of ventilation shall continue during the period that the work is carried out. The ventilation should safely disperse any released refrigerant away from the work area or external to building envelope.

During Repairs To Sealed Components: All power must be removed from the equipment being worked on prior to any removal of sealed covers, etc. If it is absolutely necessary to have an electrical supply to equipment during servicing, then a constant leak detector shall be located at the most critical point to warn of a potentially hazardous situation.

Checks And Repairs To Electrical Devices:

- Repair and maintenance to electrical components shall include initial safety checks and component inspection procedures. If a fault exists that could compromise safety, then no electrical supply shall be connected to the circuit until it is satisfactorily dealt with. If the fault cannot be corrected remove power supply to unit. **DO NOT OPERATE.**
- Initial safety checks shall include:
 - That capacitors are discharged: this shall be done in a safe manner to avoid possibility of sparking;
 - That no live electrical components and wiring are exposed while charging, recovering or purging the system;
 - Verify unit is properly grounded.
- Particular attention shall be paid to the following to ensure that by working on electrical components, the casing is not altered in such a way that the level of protection is affected. This shall include damage to cables, excessive number of connections, terminals not made to original specification, damage to seals, incorrect fitting of glands, etc.
- Ensure that the apparatus is mounted securely.
- Ensure that seals or sealing materials have not degraded to the point that they no longer serve the purpose of preventing the ingress of flammable atmospheres. Replacement parts shall be in accordance with the manufacturer's specifications.

The following is a list of important considerations when working with R-32 equipment:

- R-32 pressure is similar to R-410A and approximately 60% higher than R-22 pressure.
- R-32 cylinders must not be allowed to exceed 125°F, they may leak or rupture.
- R-32 must never be pressurized with a mixture of compressed air, it may become MORE flammable.
- Servicing equipment and components must be specifically designed for use with R-32 and dedicated to prevent contamination.
- Manifold sets must be equipped with gauges capable of reading 750 psig (high side) and 200 psig (low side), with a 500-psig low-side retard.
- Gauge hoses must have a minimum 750-psig service pressure rating.
- Recovery cylinders must have a minimum service pressure rating of 400 psig, (DOT 4BA400 and DOT BW400 approved cylinders).
- POE (Polyol-Ester) lubricants must be used with R-32 equipment.
- To prevent moisture absorption and lubricant contamination, do not leave the refrigeration system open to the atmosphere for extended periods of time.
- If unit refrigerant is low, recover the refrigerant, evacuate, and recharge unit to nameplate amount.
- If there is any amount of refrigerant in the system charge from the low side.
- Always charge by liquid inverted.

NOTE: Sealed system repairs to cool-only models require the installation of a liquid line drier.

NOTE: Sealed system repairs to models with a heat pump require the installation of a suction side drier.

Verify with tool manufacturers that all tools used during this repair are non-sparking and can be used with A2L Refrigerants.

No halide torches for leak testing.

Refrigerant monitors or detectors must be used to detect refrigerant in the work area.

- R-32 A2L Refrigerant Recovery System.
- Vacuum Pump rated for A2L refrigerant (capable of 300 microns or less vacuum.)
- Nitrogen bottle with purging and pressurizing capabilities up to 550 psi.
- Oxy/ Acetylene torch or similar equipment utilized for brazing.
- Non-Sparking (Not Halide) Electronic Leak Detector rated for detecting A2L refrigerant.
- Digital refrigerant scale

R-32 SEALED SYSTEM REPAIR

Required Equipment

- Refrigeration Gauges rated for A2L Refrigerants with temp scales for R-32 refrigerant.
- Gauge Manifold (Right handed threads).
- A2L compatible Vacuum Gauge capable of 300 microns or less.
- Nitrogen regulator for purging and testing, rated to 800 psi. (Capable of low psi flow)
- Pipe tubing cutter.
- Refrigerant recovery cylinder. (Flammable A2L label)
- Ventilation fan.
- Class ABC fire extinguisher.
- Process Tube adapter kit
- Recovery access tool.
- Purge hose fittings
- Pinch off and opening tools



ABC Fire Extinguisher



Recovery Machine



Vaccum Pump



Nitrogen



Guage Manifold



Nitrogen Regulator



Vaccum Guage



Recovery access tool



Process tube adapter kit



Purge hose fittings



Pinch off and opening tools



R-32 SEALED SYSTEM REPAIR

Refrigerant Removal, Recovery, and Evacuation

NOTE: When accessing the refrigerant in the system to make repairs or for any other purpose, conventional procedures shall be used. However, for FLAMMABLE REFRIGERANTS (R-32 is classified in the A2L group for mildly flammable refrigerants) it is important that best practice is followed since flammability is a consideration. Follow all EPA 608 regulations and procedures along with AHRI 15 Best Practices for A2L refrigerants.

 **Warning:** Ensure sufficient ventilation at the repair place.

 **Warning:** Ensure there are no open flame sources or hot surfaces that exceed 1200°F in the work area.

 **Warning:** Discharge capacitors in a way that won't cause any spark. The standard procedure to short circuit the capacitor terminals usually creates sparks.

NOTICE: Ensure that the following precautions are taken prior to opening the sealed system.

- Verify Recovery machine is rated for A2L refrigerants.
 - Mark the Job site inspection area as flammable work zone using appropriate signs.
 - Utilize a Refrigerant leak detector or refrigerant monitor to sense the area for the presence of refrigerants.
 - Disconnect all power supply to unit.
 - Properly ground all equipment and hoses along with tank to prevent a static build up .
 - Ensure adequate ventilation is provided for the job site.
 - Do not mix A2L refrigerant Gages and hoses with other refrigerants.
 - Keep exposure of refrigerant to Air to as minimum as possible (creates a dangerous condition).
 - Under no circumstances is the mixing of refrigerants in the recovery cylinders allowed and should be strictly avoided at all times. Do not introduce oxygen into any recovery cylinders.
1. Install a piercing valve to recover refrigerant from the sealed system. (Piercing valve must be removed from the system before recharging.)
 2. Recover refrigerant to EPA sec. 608 standards. If a low charge is suspected weigh recovered refrigerant and compare to unit nameplate.

NOTE: DO NOT RECOVER TO A VACUUM PRIOR TO FLUSHING WITH NITROGEN. STOP RECOVERY AT 0-5 PSI.

3. Flush refrigerant out of system with a dry nitrogen purge, make sure you energize and de-energize all reversing valves and solenoid valves to release any trapped refrigerant.(3-5 minutes).
4. Perform an evacuation to 29.9 in. hg. and break vacuum with Dry Nitrogen.
5. Re-purge the unit for 3-5 mins or until the nitrogen flows out both process tubes.
6. Re-evacuate unit to 29.9 in. hg. and break vacuum with Dry Nitrogen.
8. Open the refrigerant circuit by cutting out components.
9. Cut off the crimp on the process tubes and install a 5/16 copper access fitting to the process tube.

Transportation

Be aware that local, state, and national codes exist that regulate the transportation of flammable gases. Be sure to become informed of the regulations and always stay compliant.

R-32 SEALED SYSTEM REPAIR

Component Replacement/Brazing

 **Warning:** Ensure sufficient ventilation at the repair place.

 **Warning:** Presence of fire extinguisher. If any hot work is to be conducted on the refrigerating equipment or any associated parts, have a ABC class fire extinguisher available to hand.

 **Warning:** No person carrying out work in relation to a REFRIGERATING SYSTEM which involves exposing any pipe work shall use any sources of ignition in such a manner that it may lead to the risk of fire or explosion. All possible ignition sources, including cigarette smoking, should be kept sufficiently far away from the site of installation, repairing, removing and disposal, during which refrigerant can possibly be released to the surrounding space. Prior to work taking place, the area around the equipment is to be surveyed to make sure that there are no flammable hazards or ignition risks.

 **Warning:** Ensure there are no open flame sources or hot surfaces that exceed 1200°F in the work area.

NOTE: When brazing is required, the following procedures shall be carried out in the right order:

1. Remove and recover refrigerant, and evacuate the system. Refer to the [refrigerant removal, recovery, and evacuation section](#) of this manual.

 **Warning:** Under no circumstances shall potential sources of ignition be used in the searching for or detection of refrigerant leaks. A halide torch (or any other detector using a naked flame) shall not be used.

2. Perform a check of the work area for the presence of flammable refrigerant prior to brazing or performing any hot work. Use a non-Sparking (Not Halide) A2L certified Electronic Leak Detector rated for detecting R-32 refrigerant.

3. Re-pipe all repairs and install all components to sealed system.

NOTE: Sealed system repairs require the installation of a liquid line drier upstream of the condenser.

NOTE: Sealed system repairs to models with a heat pump require the installation liquid line drier on the cooling liquid line.

Refer to Figure 701 for installation location of liquid line drier on unit with heat pump.

4. Purge nitrogen through the unit. at approximately 2-3 psi through the duration of the brazing process. (Nitrogen must be purging through the unit while any brazing is being performed.)

5. Pressure test unit to 550 psi minimum and hold pressure for 30 minutes minimum. Inspect for any leaks with a leak detection fluid and repair as required. Repeat as required until system passes leak test.

6. Triple evacuate the unit to achieve a 500 micron level.

7. Pressurize nitrogen to 550 psi and leak test all connections with a leak detection fluid. Repair any leaks found.

8. Reassemble sealed enclosures accurately. If seals are worn, replace them.

9. Charge the system with the amount of refrigerant specified on the model nameplate. [Refer to the refrigerant charging section of this manual for charging procedures.](#)

R-32 SEALED SYSTEM REPAIRS

Refrigerant Charging

WARNING: Electrical Shock Hazard

Disconnect all power to the unit before starting maintenance. All electrical connections and wiring **MUST** be installed by a qualified electrician and conform to all codes which have jurisdiction. Failure to do so can result in property damage, severe electrical shock or death.



WARNING: This Product uses R-32 Refrigerant

Do not use means to accelerate the defrosting process or to clean, other than those recommended by the manufacturer.

When not installed, the appliance shall be stored in a room without continuously operating ignition sources (for example: open flames, an operating gas appliance or an operating electric heater).

Do not pierce or burn.

Be aware that refrigerants may not contain an odor.



Refrigerant
Safety Group
A2L

WARNING: Refrigeration System under High pressure

Do not puncture, heat, expose to flame or incinerate. Only certified refrigeration technicians should service this equipment. R32 systems operate at higher pressures than R22 equipment. Appropriate safe service and handling practices must be used.

WARNING: Freeze Hazard

Proper safety procedures must be followed, and all PPE must be utilized when working with liquid refrigerant. Failure comply could result in minor to moderate injury.

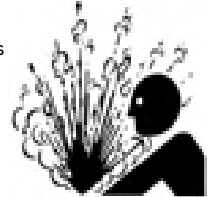

NOTE: Always weigh in refrigerant based on the model nameplate.

Warning:

- Ensure that contamination of different refrigerants does not occur when using charging equipment.
- Hoses or lines shall be as short as possible to minimise the amount of refrigerant contained in them.
- Charge unit with refrigerant cylinder in the inverted position to obtain liquid refrigerant.
- Charge the unit according to the amount on the name plate matching the unit.
- Extreme care shall be taken not to overfill the REFRIGERATING SYSTEM.
- Prior to recharging a system, it shall be pressure-tested with the dry nitrogen.

NOTE: Because the refrigerant system is a sealed system, service process tubes will have to be installed. First install a line tap and recover refrigerant from system. Refer to the [Refrigerant removal section](#) of this manual for procedures.

The acceptable method for charging the sealed system is the Weighed in Charge Method. The weighed in charge method is applicable to all units. It is the preferred method to use, as it is the most accurate.

The weighed in method should always be used whenever a charge is removed from a unit such as for a leak repair, compressor replacement, or when there is no refrigerant charge left in the unit. To charge by this method, requires the following steps:

-  **Warning:** Ensure sufficient ventilation at the repair place.

-  **Warning:** Ensure there are no open flame sources or hot surfaces that exceed 1200°F in the work area.

1. Recover Refrigerant in accordance with EPA regulations. (Refer to [Refrigerant Removal, Recovery, and Evacuation Section](#)).

NOTE: If a low charge is suspected weigh recovered refrigerant and compare to unit nameplate.

NOTE: Access valves must be removed after charging is complete to return this unit to a sealed system.

2. Weigh in the refrigerant charge with the proper quantity of R-32 refrigerant per model nameplate.
3. Crimp the process tube and solder the end shut.
4. Start unit, and verify performance.

NOTE: EPA Section 608 regulations require that if a system is charged with flammable refrigerant it must have red markings on the access ports (Process tube).

R-32 SEALED SYSTEM REPAIRS

Compressor Replacement

⚠ WARNING	
	ELECTRIC SHOCK HAZARD Turn off electric power before service or installation. Extreme care must be used, if it becomes necessary to work on equipment with power applied. Failure to do so could result in serious injury or death.

⚠ WARNING	
	HIGH PRESSURE HAZARD Sealed Refrigeration System contains refrigerant and oil under high pressure. Proper safety procedures must be followed, and PPE must be utilized when working with refrigerants. Failure to follow these procedures could result in serious injury or death.

⚠ WARNING	
	EXPLOSION HAZARD The use of nitrogen requires a pressure regulator. Follow all safety procedures and wear protective safety clothing etc. Failure to follow proper safety procedures could result in serious injury or death.

⚠ CAUTION	
	FREEZE HAZARD Proper safety procedures must be followed, and proper protective clothing must be worn when working with liquid refrigerant. Failure to follow these procedures could result in minor to moderate injury.

⚠ WARNING	
	NEVER , under any circumstances, liquid charge a rotary-compressor through the LOW side. Doing so would cause permanent damage to the new compressor. Use a charging adapter.

1. Be certain to perform all necessary electrical and refrigeration tests to be sure the compressor is actually defective before replacing.

2. Recover all refrigerant from the system through the process tubes. Refer to [Refrigerant Removal, Recovery, and Evacuation](#) Section of this manual).

PROPER HANDLING OF RECOVERED REFRIGERANT ACCORDING TO EPA REGULATIONS IS REQUIRED.

3. After all refrigerant has been recovered, cut and remove compressor. Be certain to have both suction and discharge process tubes open to atmosphere.

4. Carefully pour a small amount of oil from the suction stub of the defective compressor into a clean container.

5. Using an acid test kit (one shot or conventional kit), test the oil for acid content according to the instructions with the kit.

6. If any evidence of a burnout is found, no matter how slight, refer to [Compressor Replacement -Special Procedure in Case of Compressor Burnout](#).

7. Install the replacement compressor.

CAUTION: Seal all openings on the defective compressor immediately. Compressor manufacturers will void warranties on units received not properly sealed. Do not distort the manufacturers tube connections.

8. Braze all connections. Refer to the [Component Replacement/Brazing section](#) of this manual.

9. Charge system with proper amount of refrigerant per the model nameplate. Refer to the [Refrigerant charging section of this manual](#).

R-32 SEALED SYSTEM REPAIRS

Compressor Replacement -Special Procedure in Case of Compressor Burnout

⚠ WARNING	
	<p>HIGH PRESSURE HAZARD Sealed Refrigeration System contains refrigerant and oil under high pressure.</p> <p>Proper safety procedures must be followed, and PPE must be utilized when working with refrigerants.</p> <p>Failure to follow these procedures could result in serious injury or death.</p>

⚠ WARNING	
	<p>ELECTRIC SHOCK HAZARD Turn off electric power before service or installation. Extreme care must be used, if it becomes necessary to work on equipment with power applied.</p> <p>Failure to do so could result in serious injury or death.</p>

⚠ WARNING	
	<p>EXPLOSION HAZARD The use of nitrogen requires a pressure regulator. Follow all safety procedures and wear protective safety clothing etc.</p> <p>Failure to follow proper safety procedures could result in serious injury or death.</p>

⚠ WARNING	
	<p>NEVER, under any circumstances, liquid charge a rotary-compressor through the LOW side. Doing so would cause permanent damage to the new compressor. Use a charging adapter.</p>

1. Recover all refrigerant and oil from the system. [Refer to Refrigerant Removal, Recovery, and Evacuation Section](#) of this manual.

2. Cut and remove compressor and capillary tube from the system.

CAUTION: Seal all openings on the defective compressor immediately. Compressor manufacturers will void warranties on units received not properly sealed. Do not distort the manufacturers tube connections.

3. Flush evaporator condenser and all connecting tubing with dry nitrogen or equivalent. Use A2L approved flushing agent to remove all contamination from system. Inspect suction and discharge line for carbon deposits. Remove and clean if necessary. Ensure all acid is neutralized.

4. Reassemble the system, including a new capillary tube assembly and strainers.

5. Install a dual port suction line drier on the common suction line and remove when the pressure differential across the drier ports reaches 3 psi. or greater.

6. Braze all connections. [Refer to the Brazing section of this manual.](#)

7. Charge system with proper amount of refrigerant per the model nameplate. [Refer to the refrigerant charging section of this manual.](#)

R-32 SEALED SYSTEM REPAIR

Replace The Reversing Valve

⚠ WARNING	
	<p>HIGH PRESSURE HAZARD Sealed Refrigeration System contains refrigerant and oil under high pressure.</p> <p>Proper safety procedures must be followed, and PPE must be utilized when working with refrigerants.</p> <p>Failure to follow these procedures could result in serious injury or death.</p>

⚠ WARNING	
	<p>EXPLOSION HAZARD The use of nitrogen requires a pressure regulator. Follow all safety procedures and wear protective safety clothing etc.</p> <p>Failure to follow proper safety procedures could result in serious injury or death.</p>

NOTICE
<p>FIRE HAZARD The use of a torch requires extreme care and proper judgment. Follow all safety recommended precautions and protect surrounding areas with fire proof materials. Have a fire extinguisher readily available. Failure to follow this notice could result in moderate to serious property damage.</p>

1. Recover all refrigerant from the system though the process tubes. Refer to [Refrigerant Removal, Recovery, and Evacuation](#) Section of this manual).

PROPER HANDLING OF RECOVERED REFRIGERANT ACCORDING TO EPA REGULATIONS IS REQUIRED.

2. Remove solenoid coil from reversing valve. If coil is to be reused, protect from heat while changing valve.

NOTE: When brazing a reversing valve into the system, it is of extreme importance that the temperature of the valve does not exceed 250°F at any time.

Wrap the reversing valve with a large rag saturated with water. "Re-wet" the rag and thoroughly cool the valve after each brazing operation of the four joints involved.

The wet rag around the reversing valve will eliminate conduction of heat to the valve body when brazing the line connection.

3. Cut all lines from reversing valve. [Refer to the Brazing section of this manual.](#)
4. Clean all excess braze from all tubing so that they will slip into fittings on new valve.
5. Remove solenoid coil from new valve.
6. Protect new valve body from heat while brazing with plastic heat sink (Thermo Trap) or wrap valve body with wet rag.
7. Fit all lines into new valve and braze lines into new valve.
8. Braze all connections. Refer to the [Brazing section of this manual.](#)
9. Pressurize with nitrogen to 550 psi and leak test all connections with a leak detection fluid. Repair any leaks found.
10. Once the sealed system is leak free, install solenoid coil on new valve.
11. Charge system with proper amount of refrigerant per the model nameplate. Refer to the [refrigerant charging section of this manual.](#)

WIRING DIAGRAMS

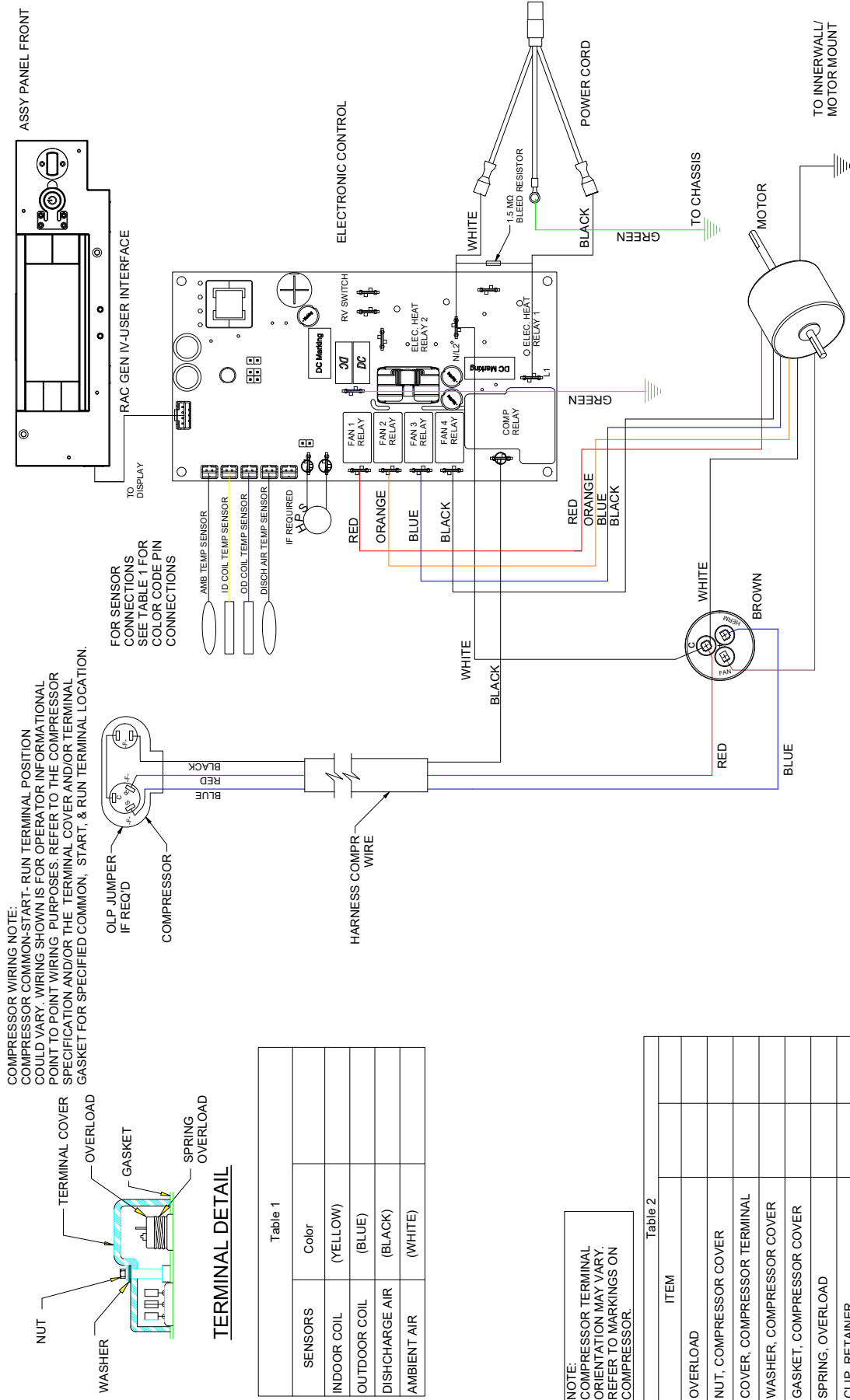

Figure 902 (KCS12B10A, KCM24B30A)

WIRING DIAGRAMS

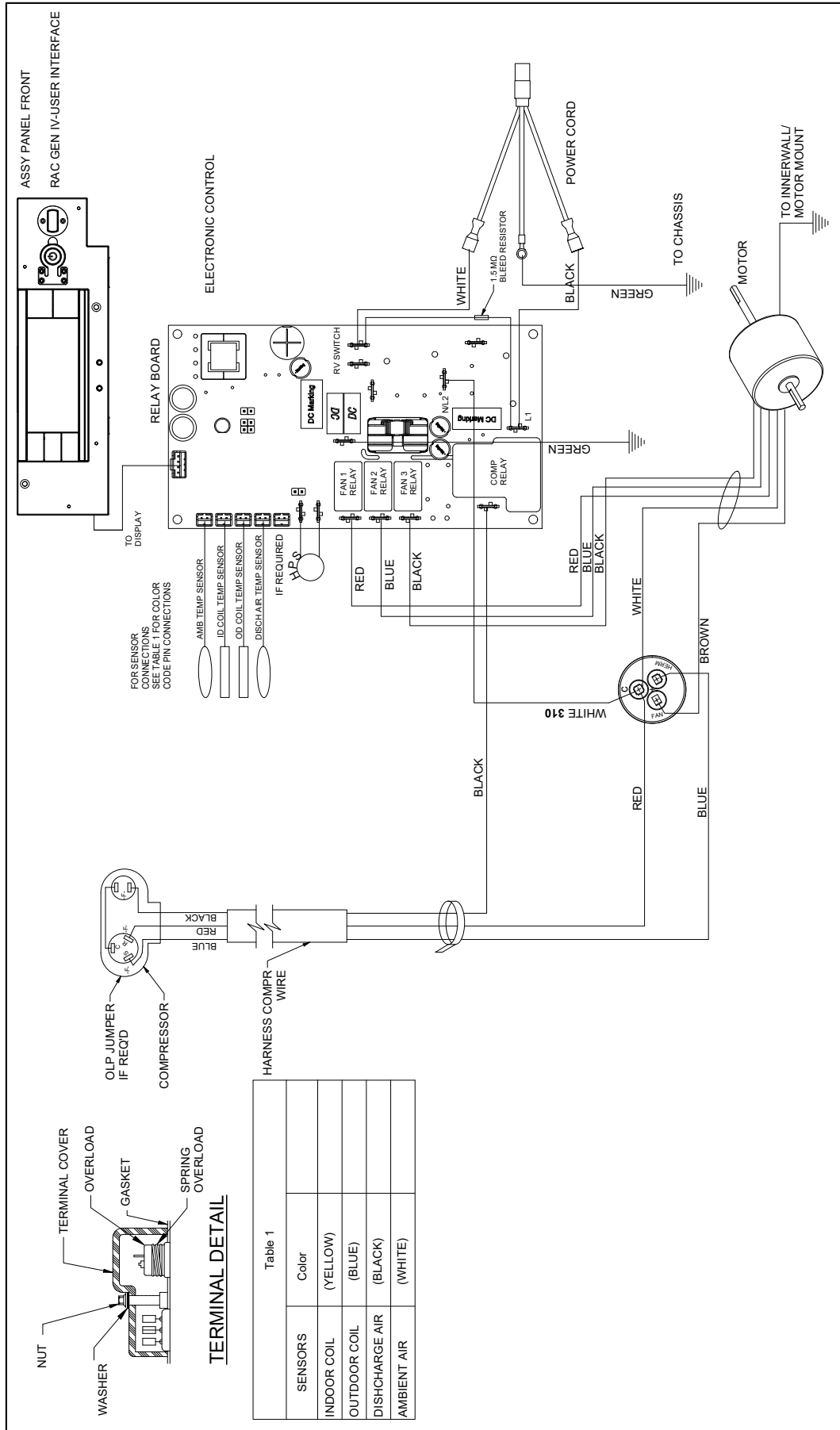
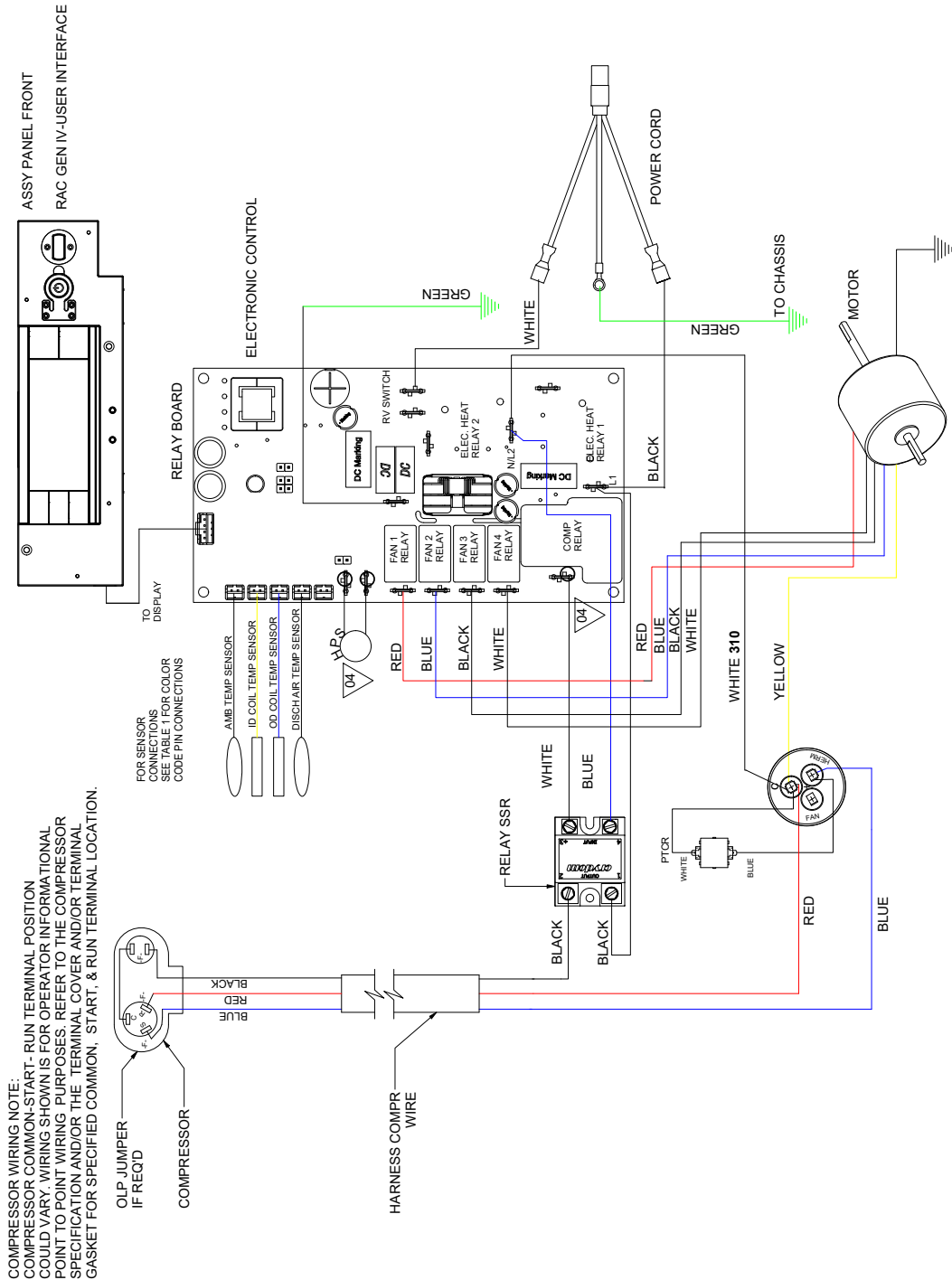
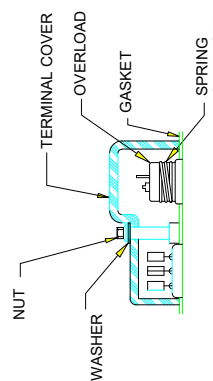

Figure 903 (KCL28B30A)

WIRING DIAGRAMS



COMPRESSOR WIRING NOTE:
COMPRESSOR COMMON-START-RUN TERMINAL POSITION COULD VARY. WIRING SHOWN IS FOR OPERATOR INFORMATIONAL POINT TO POINT WIRING PURPOSES. REFER TO THE COMPRESSOR SPECIFICATION AND/OR THE TERMINAL COVER AND/OR TERMINAL GASKET FOR SPECIFIED COMMON, START, & RUN TERMINAL LOCATION.



TERMINAL DETAIL

SENSORS	FIND NUMB.
INDOOR COIL	332 (YELLOW)
OUTDOOR COIL	333 (BLUE)
DISCHARGE AIR	389 (BLACK)
AMBIENT AIR	442 (WHITE)

NOTE:
COMPRESSOR TERMINAL ORIENTATION MAY VARY. REFER TO MARKINGS ON COMPRESSOR.

Table 2

- | ITEM |
|----------------------------|
| OVERLOAD |
| NUT, COMPRESSOR COVER |
| COVER, COMPRESSOR TERMINAL |
| WASHER, COMPRESSOR COVER |
| GASKET, COMPRESSOR COVER |
| SPRING, OVERLOAD |
| CLIP, RETAINER |

Figure 904 (KCL36B30A)

WIRING DIAGRAMS

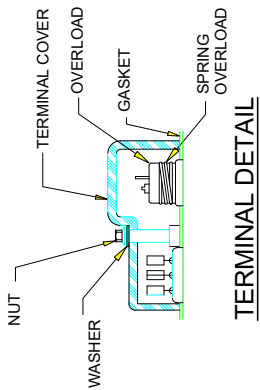
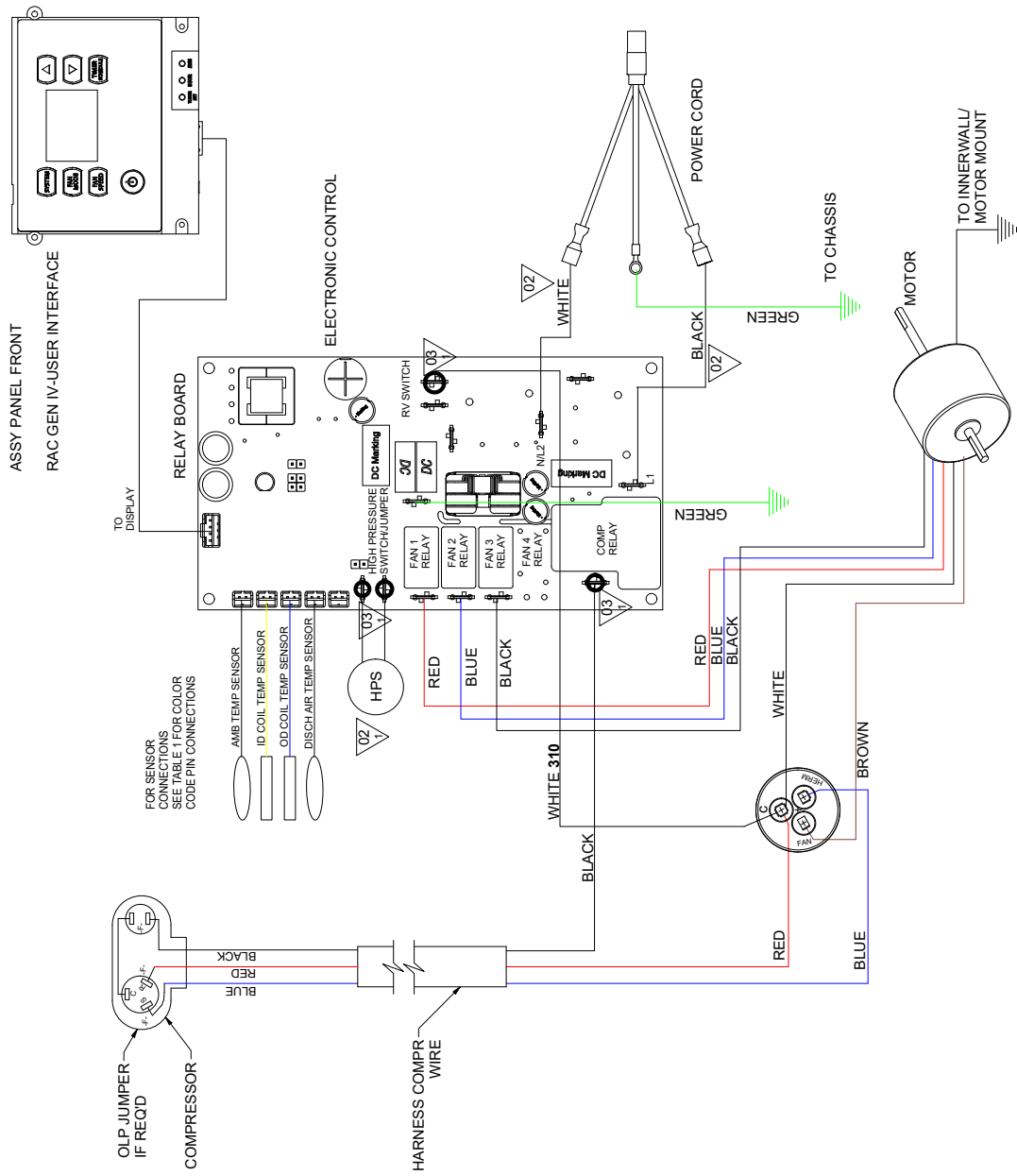
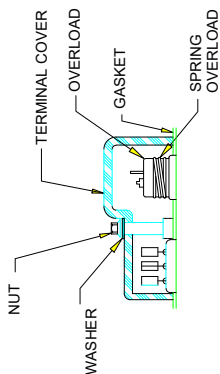
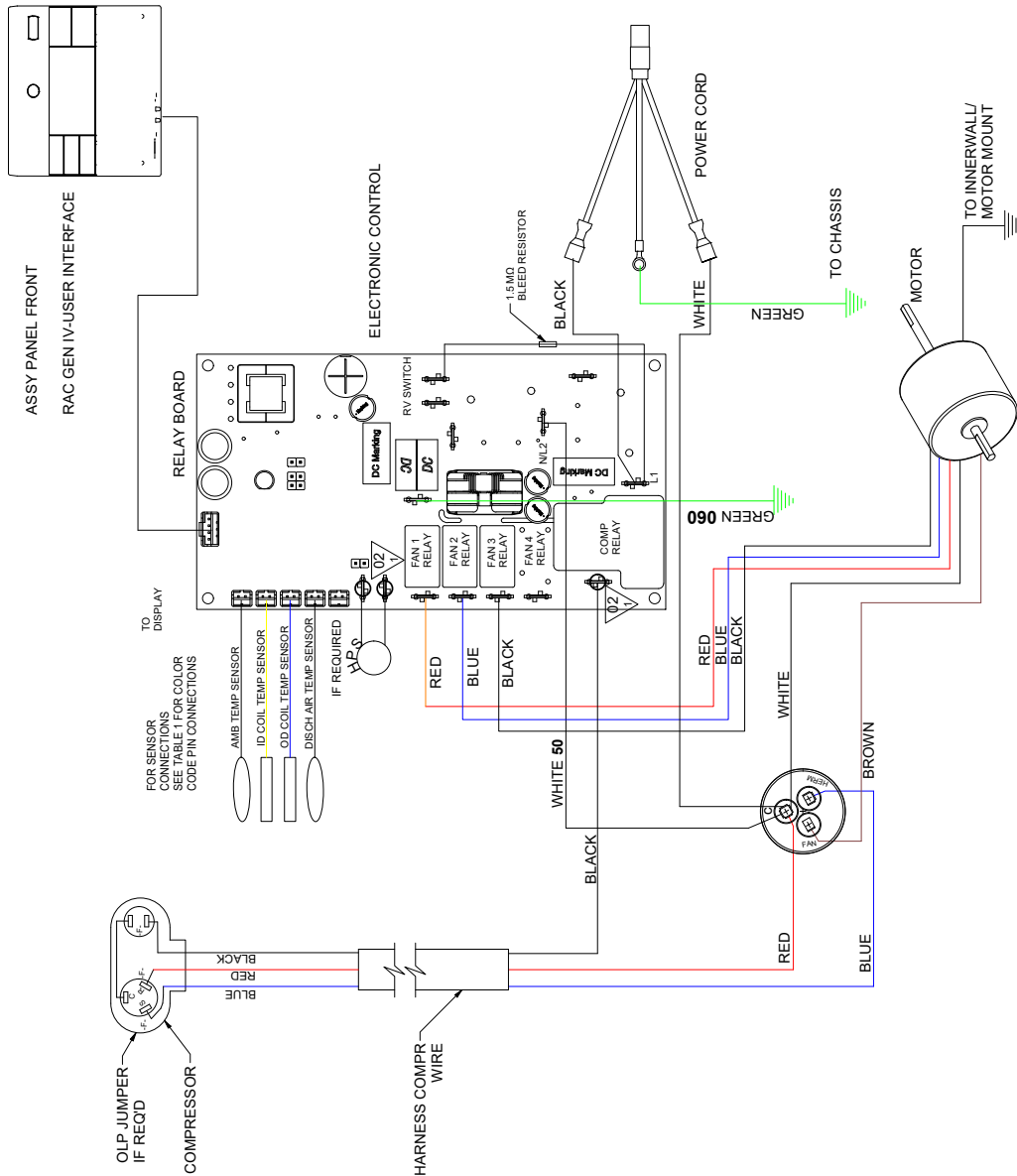

Table 1

SENSORS	FIND NUM.
INDOOR COIL	332 (YELLOW)
OUTDOOR COIL	333 (BLUE)
AMBIENT AIR	334 (WHITE)
DISCHARGE AIR	389 (BLACK)

Figure 905 (KCQ08B10A)

WIRING DIAGRAMS



TERMINAL DETAIL

Table 1

SENSORS	
INDOOR COIL	(YELLOW)
OUTDOOR COIL	3 (BLUE)
DISHCHARGE AIR	(BLACK)
AMBIENT AIR	(WHITE)

Figure 906 (WCT16B30A)

AVAILABLE ACCESSORIES

Premium Carbon Filters

Remove odors and VOCs (volatile organic compounds). Achieve up to a MERV 6 rating when used with standard filter. 3 pack



Model	Kit No.
KCQ and KEQ	KWCFQ
KCS, KES and KHS	KWCFS
KCM, KEM and KHM	KWCFM
KCL, KEL and KHL	KWCFL

Window Mounting Kits: Kühl+

Window kits are included with cooling only models, but are an accessory item for Kühl+ heat/cool models. Window kits are required for installation of Kühl+ models in a window.

Heat/Cool Models	Kit No.
KES12A33A, KES16A33A, KHS10A10A and KHS12A33A.	KWIKSB
KEM18A34A and KHM18A34A.	KWIKMB
KEL24A35A, KEL36A35A and KHL24A35A.	KWIKLB



Drain Kit

Allows field installed drain tube to be installed to the bottom of the sleeve to route the condensate from the unit.

Model	Kit No.
All Kühl Series Models	DC2



APPENDIX

Interactive Parts Viewer

All Friedrich Service Parts can be found on our online interactive parts viewer.

Please click on the link below:

[Interactive Parts Viewer](#)

For Further Assistance contact Friedrich customer service at **(1-800-541-6645)**.

Limited Warranty

Current warranty information can be obtained by referring to <https://www.friedrich.com/professional/support/product-resources>

APPENDIX

Thermistor Resistance Values (This Table Applies to All Thermistors)

TEMP	RESISTENCE (K Ohms)			RESISTANCE TOLERANCE %	
	MIN	CENTR	MAX	MIN	MAX
-25	210.889	225.548	240.224	6.50	6.51
-20	178.952	190.889	202.825	6.25	6.25
-15	151.591	161.325	171.059	6.03	6.03
-10	128.434	136.363	144.292	5.81	5.81
-5	108.886	115.340	121.794	5.60	5.60
0	92.411	97.662	102.912	5.38	5.38
5	78.541	82.812	87.083	5.16	5.16
10	66.866	70.339	73.812	4.94	4.94
15	57.039	59.864	62.688	4.72	4.72
20	48.763	51.060	53.357	4.50	4.50
25	41.786	43.654	45.523	4.28	4.28
30	35.896	37.415	38.934	4.06	4.06
31	34.832	36.290	37.747	4.02	4.02
32	33.803	35.202	36.601	3.97	3.97
33	32.808	34.150	35.492	3.93	3.93
34	31.846	33.133	34.421	3.89	3.89
35	30.916	32.151	33.386	3.84	3.84
36	30.016	31.200	32.385	3.80	3.80
37	29.144	30.281	31.418	3.75	3.75
38	28.319	29.425	30.534	3.76	3.77
39	27.486	28.532	29.579	3.67	3.67
40	26.697	27.701	28.704	3.62	3.62
45	23.116	23.931	24.745	3.40	3.40
50	20.071	20.731	21.391	3.18	3.18
55	17.474	18.008	18.542	2.96	2.96
60	15.253	15.684	16.115	2.75	2.75
65	13.351	13.697	14.043	2.53	2.53
66	13.004	13.335	13.666	2.48	2.48
67	12.668	12.984	13.301	2.44	2.44
68	12.341	12.644	12.947	2.39	2.39
69	12.024	12.313	12.603	2.35	2.35
70	11.716	11.993	12.269	2.31	2.31
71	11.418	11.682	11.946	2.26	2.26
72	11.128	11.380	11.633	2.22	2.22
73	10.846	11.088	11.329	2.18	2.18
74	10.574	10.804	11.034	2.13	2.13
75	10.308	10.528	10.748	2.09	2.09
76	10.051	10.260	10.469	2.04	2.04
77	9.800	10.000	10.200	2.00	2.00
78	9.550	9.748	9.945	2.03	2.03
79	9.306	9.503	9.699	2.07	2.07
80	9.070	9.265	9.459	2.10	2.10
81	8.841	9.033	9.226	2.13	2.13
82	8.618	8.809	9.000	2.17	2.17
83	8.402	8.591	8.780	2.20	2.20
84	8.192	8.379	8.566	2.23	2.23
85	7.987	8.172	8.358	2.27	2.27
86	7.789	7.972	8.155	2.30	2.30
87	7.596	7.778	7.959	2.33	2.33
88	7.409	7.589	7.768	2.37	2.37
89	7.227	7.405	7.583	2.40	2.40
90	7.050	7.226	7.402	2.43	2.43
91	6.878	7.052	7.226	2.47	2.47
92	6.711	6.883	7.055	2.50	2.50
93	6.548	6.718	6.889	2.53	2.53
94	6.390	6.558	6.727	2.57	2.57
95	6.237	6.403	6.569	2.60	2.60
96	6.087	6.252	6.417	2.63	2.63
97	5.942	6.105	6.268	2.67	2.67
98	5.800	5.961	6.122	2.70	2.70
99	5.663	5.822	5.981	2.73	2.73
100	5.529	5.686	5.844	2.77	2.77
105	4.912	5.060	5.208	2.93	2.93
110	4.371	4.511	4.651	3.10	3.10
115	3.898	4.030	4.161	3.27	3.27
120	3.482	3.606	3.730	3.43	3.43

Figure 711 Thermistor Values

FRIEDRICH AUTHORIZED PARTS DEPOTS

United Products Distributors Inc.

4030A Benson Ave
Halethorpe, MD 21227
888-907-9675
c.businsky@updinc.com

Shivani Refrigeration & Air Conditioning Inc.

2259 Westchester Ave.
Bronx, NY 10462
sales@shivanionline.com

NEUCO Inc.

515 W Crossroads Parkway
Bolingbrook, IL 60440
312.809.1418
borr@neuco.com

The Gabbert Company

6868 Ardmore
Houston, Texas 77054

713-747-4110
800-458-4110

Johnstone Supply of Woodside

27-01 Brooklyn Queens Expway
Woodside, New York 11377

718-545-5464
800-431-1143

Reeve Air Conditioning, Inc.

2501 South Park Road
Hallandale, Florida 33009

954-962-0252
800-962-3383

Total Home Supply

26 Chapin Rd Ste 1109
Pine Brook, NJ 07058

877-847-0050

support@totalhomesupply.com
<https://www.totalhomesupply.com/brands/Friedrich.html>



FRIEDRICH

TECHNICAL SUPPORT CONTACT INFORMATION

Friedrich Air Conditioning Co.
10001 Reunion Place, Suite 500 • San Antonio, Texas 78216
1-800-541-6645
www.friedrich.com