



# Parts Manual

Mfg. No: 040786-00  
22,000 Watt Standby Generator (Briggs & Stratton)



<b>Model Components</b>	<b>Page</b>
Accessory Group.....	4
Alternator Group.....	6
Circuit Breaker Group.....	8
Control Panel Group.....	10
Decals Group.....	14
Enclosure Group.....	16
Fuel, Duct & Support Group.....	18
Power Group.....	24
6845-00 - Fuel Regulator Heater.....	26
Fuel Regulator Heater.....	27
6840-00 - Oil Sump Warmer.....	29
Oil Sump Warmer.....	30
6869-00 - Battery Warmer.....	32
Battery Warmer.....	33
6872-00 - Maintenance.....	35
Maintenance.....	36
6574-01 - Infohub.....	38
Infohub.....	39
6581-00 - Uninterruptible Power Supply - (UPS).....	41
Uninterruptible Power Supply - (UPS).....	42
6491-01 - Estop Switch.....	44
Estop Switch.....	45
6428-00 - USB Cable.....	47
USB Cable.....	48
6631-00 - Surge Protective Device (SPD).....	50
Surge Protective Device (SPD).....	51
Torque Specification Chart.....	53

# Accessory Group

Note: Unless noted otherwise, use the standard torque specifications

Mfg. No: 040786-00

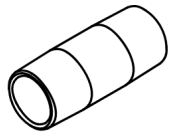

0030

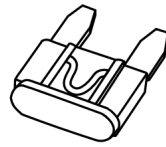

0040



0050

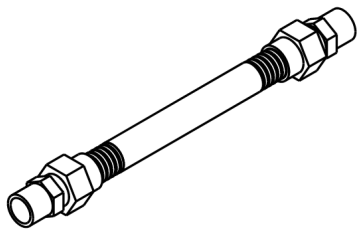

0070

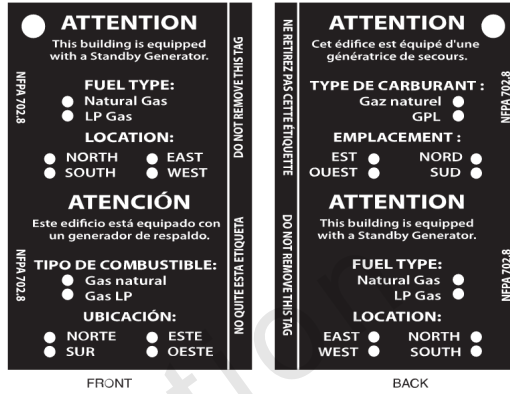

0100



0120

Not For  
Reproduction

## Accessory Group

REF NO	PART NO	QTY	DESCRIPTION
0030	206976GS	1	FITTING
0040	198573GS	2	FUSE, Auto Type, 15 Amp
0050	198460GS	4	PLUG, Dome
0070	202295GS	1	HOSE-FLEX NG/LPG
0100	706988	1	HANG TAG-ATTN. STANDBY EQUIPMENT
0120	314290GS	1	KEY, Latch

Not For Reproduction

# Alternator Group

Note: Unless noted otherwise, use the standard torque specifications

Mfg. No: 040786-00

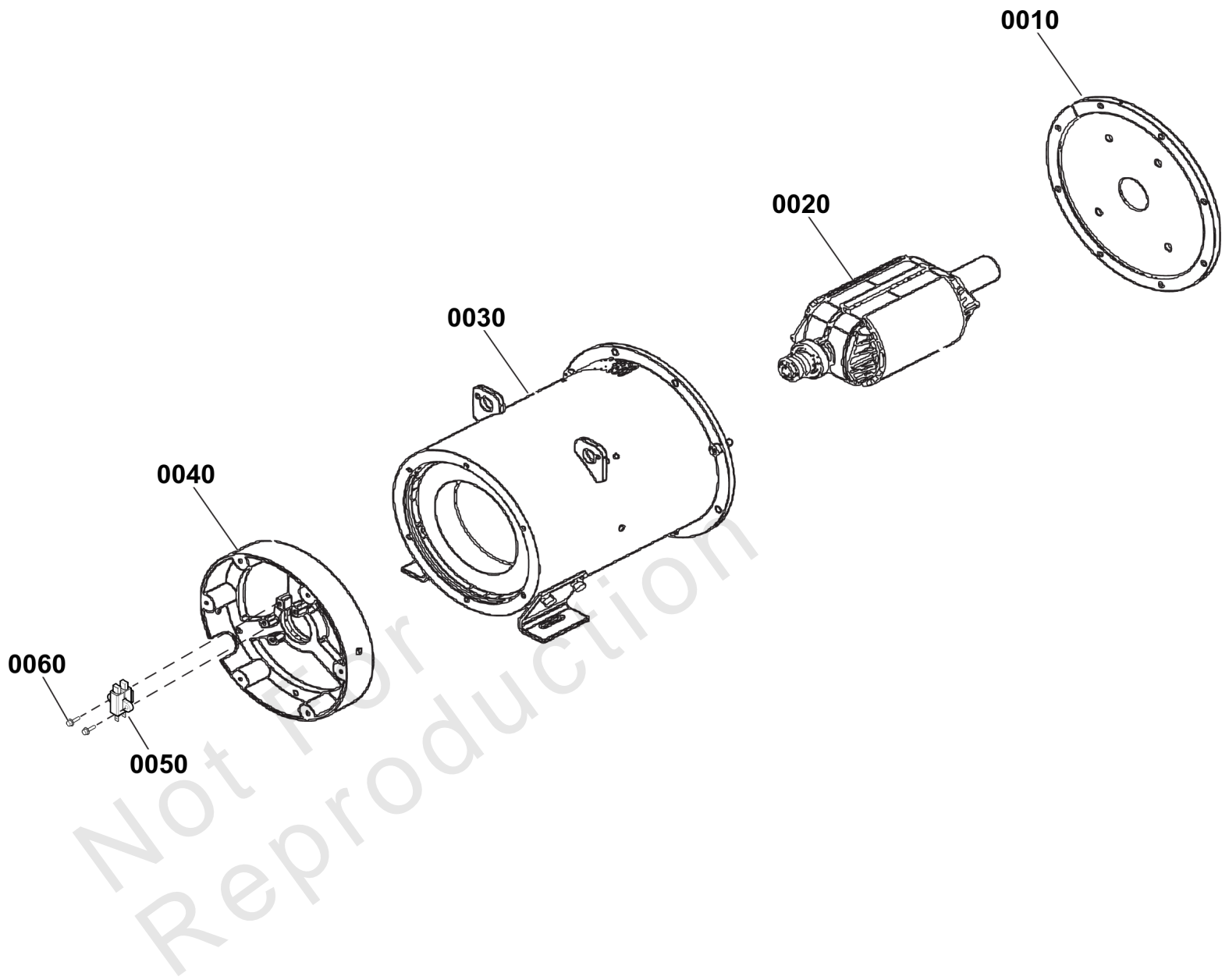

## Alternator Group

REF NO	PART NO	QTY	DESCRIPTION
0010	84007278	1	ADAPTER
0020	84010877	1	STATOR
0030	84010876	1	ROTOR ASSEMBLY
0040	84007279	1	HOUSING, Bearing
0050	66386GS	1	ASSY, Holder, Brush
0060	66849GS	2	TAPTITE, M5 - 0.8 x 16

Not For Reproduction

# Circuit Breaker Group

Note: Unless noted otherwise, use the standard torque specifications

Mfg. No: 040786-00

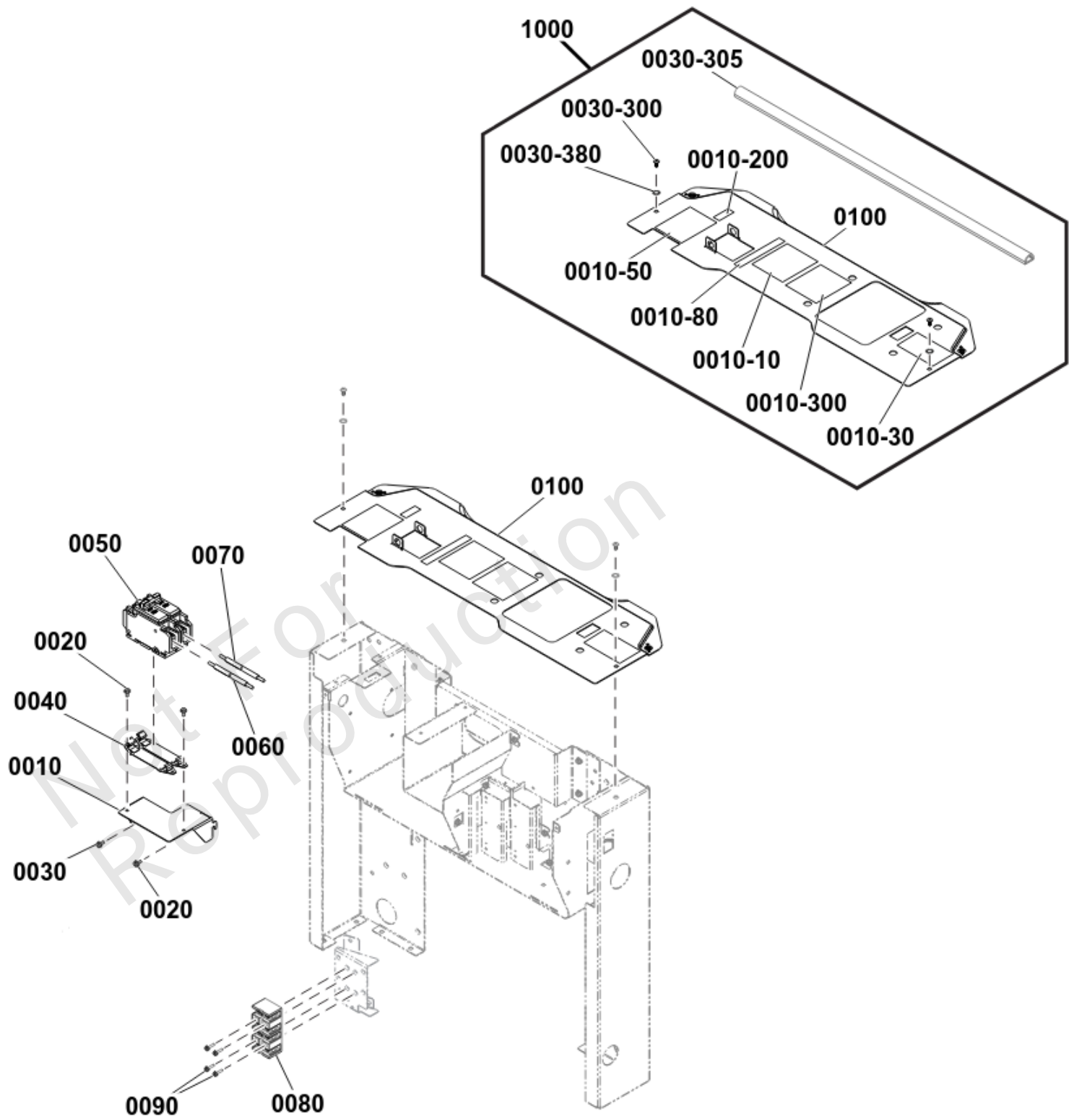

## Circuit Breaker Group

REF NO	PART NO	QTY	DESCRIPTION
0010	-----	1	BRACKET
0020	194561GS	3	HHS, Trilobular, #10-32 x 3/8
0030	-----	1	SCREW, 10-16 X 3/8
0040	192770GS	2	BRACKET, Mounting / Breaker
0050	311318GS	1	BREAKER, Circuit, 100A
0060	-----	1	WIRE, Power
0070	-----	1	WIRE, Power
0080	84006390	1	BLOCK, Terminal
0090	707520	4	SCREW, Taptite
0100	-----	1	COVER, Control Panel
1000	84007050	1	KIT, Cover, Control Panel -(Includes Ref. Nos. 0010-10, 0010-30, 0010-50, 0010-80, 0010-200, 0010-300, 0030-300, 0030-305, 0030-380, 0100)
0010-10	-----	1	DECAL-WARNING, SHOCK -(Part information located in Decals Group.)
0010-30	-----	1	DECAL-WARNING, FUSE -(Part information located in Decals Group.)
0010-50	-----	1	DECAL, Warning, Manual -(Part information located in Decals Group.)
0010-80	-----	1	DECAL-DISCONNECT -(Part information located in Decals Group.)
0010-200	-----	1	DECAL, FCC, ICES-3 -(Part information located in Decals Group.)
0010-300	-----	1	DECAL, Warning -(Part information located in Decals Group.)
0030-300	84006392	2	SCREW, #10-32 X 3/8 -(Part information located in Control Panel Group.)
0030-305	-----	1	SEAL, Bulb -(Part information located in Control Panel Group.)
0030-380	-----	2	WASHER, Ext. M6 - 1/4" Shakeproof -(Part information located in Control Panel Group.)
0100	-----	1	COVER, Control Panel

# Control Panel Group

Note: Unless noted otherwise, use the standard torque specifications

Mfg. No: 040786-00

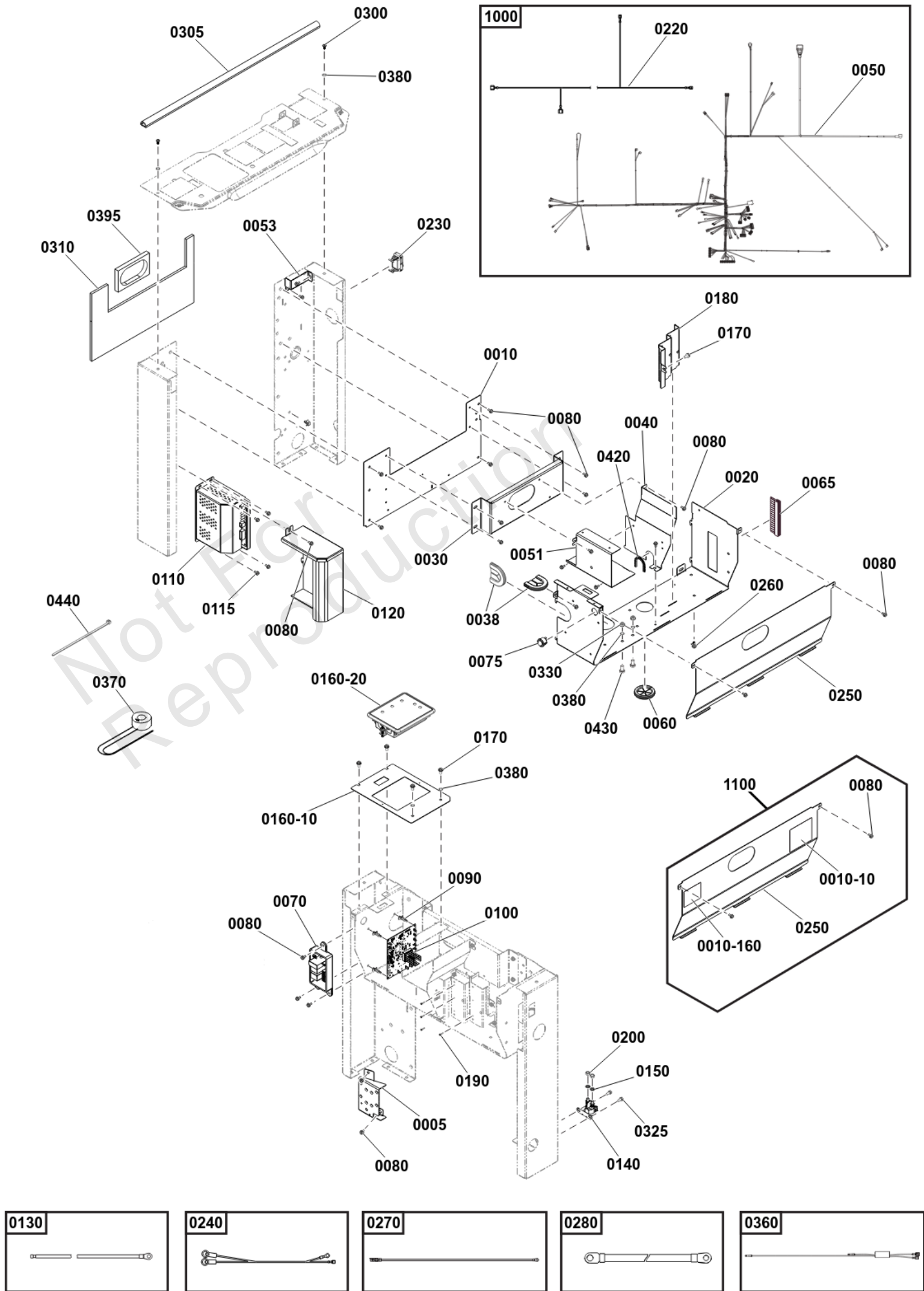

## Control Panel Group

REF NO	PART NO	QTY	DESCRIPTION
0005	-----	1	BRACKET, Terminal Block
0010	-----	1	PANEL
0020	-----	1	BASE
0030	-----	1	PANEL
0038	-----	2	GROMMET
0040	-----	1	DIVIDER
0051	-----	1	BRACKET
0053	-----	1	BRACKET
0060	-----	2	GROMMET
0065	-----	2	GROMMET
0070	772336	1	ASSEMBLY, Relay
0075	315551GS	1	SWITCH, Rocker
0080	194561GS	18	HHS, Trilobular, #10-32 x 3/8
0090	772379	4	SUPPORT, Circuit Board
0100	84010843	1	ASSEMBLY, AVR
0110	772376	1	CHARGER, Battery
0115	-----	4	SCREW, #10-32 X 1/2
0120	-----	1	COVER
0130	84007028	1	WIRE, Power
0140	1755381YP	1	SOLENOID, L-BRACKET
0150	22129GP	2	WASHER, 5/16 - M8, Lock
0160-10	-----	1	COVER, Control Panel
0160-20	84007051	1	CONTROLLER
0170	-----	12	SCREW, 10-16 X 3/8
0180	-----	1	BRACKET
0190	314691GS	5	SCREW, Taptite, M2.5-.45 X 12
0200	703331	2	NUT, 5/16-24
0230	772341	1	SWITCH, Rocker
0240	84007026	1	HARNESS, Intermediate, Relay
0260	195733GS	4	MOUNT, Tie Wrap
0270	84008694	1	HARNESS, Battery
0280	706527	1	WIRE, Ground
0300	-----	2	SCREW, #10-32 X 3/8
0305	-----	1	SEAL, Bulb
0310	-----	1	INSULATION
0325	704130	3	SCREW, HEX, 1/4-20X.5
0330	5025391SM	2	NUT, Hex Nylock, Flange, 1/4-20
0360	84004583	1	HARNESS
0370	772339	2	TRANSFORMER, Current, 150:5
0380	26850GS	7	WASHER, Ext. M6 - 1/4" Shakeproof
0395	-----	1	SEAL
0420	-----	1	GROMMET
0430	703818	2	CAPSCREW, 1/4-20X0.5
0440	29333AGS	3	TIEWRAP, 7 LG BLK
1000	84010878	1	KIT, Harness -(Includes Ref. Nos. 0050, 0220)
0050	-----	1	HARNESS, Main
0220	-----	1	HARNESS, Fuel Select
1100	84011527	1	KIT, Panel, Control Box -(Includes Ref. Nos. 0010-10, 0010-160, 0080, 0250)
0010-10	-----	1	DECAL-WARNING, SHOCK -(Part information located in Decals Group.)

# Control Panel Group

Note: Unless noted otherwise, use the standard torque specifications

Mfg. No: 040786-00

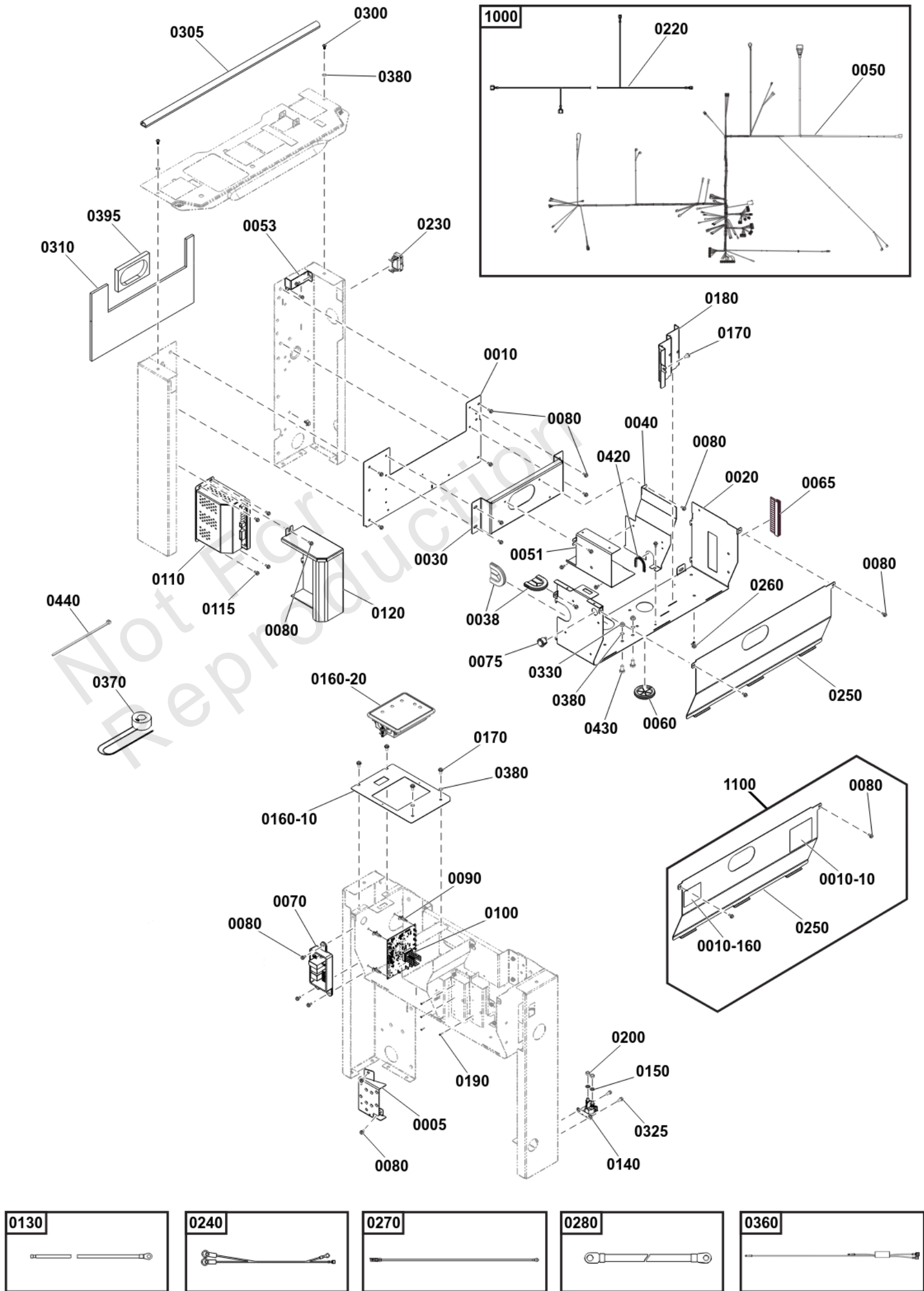

## ***Control Panel Group***

<b>REF NO</b>	<b>PART NO</b>	<b>QTY</b>	<b>DESCRIPTION</b>
0010-160	-----	1	DECAL, Warning -(Part information located in Decals Group.)
0080	194561GS	2	HHS, Trilobular, #10-32 x 3/8
0250	-----	1	PANEL, Control Box

Not For Reproduction

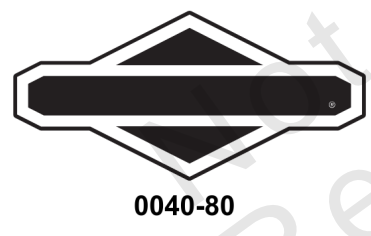
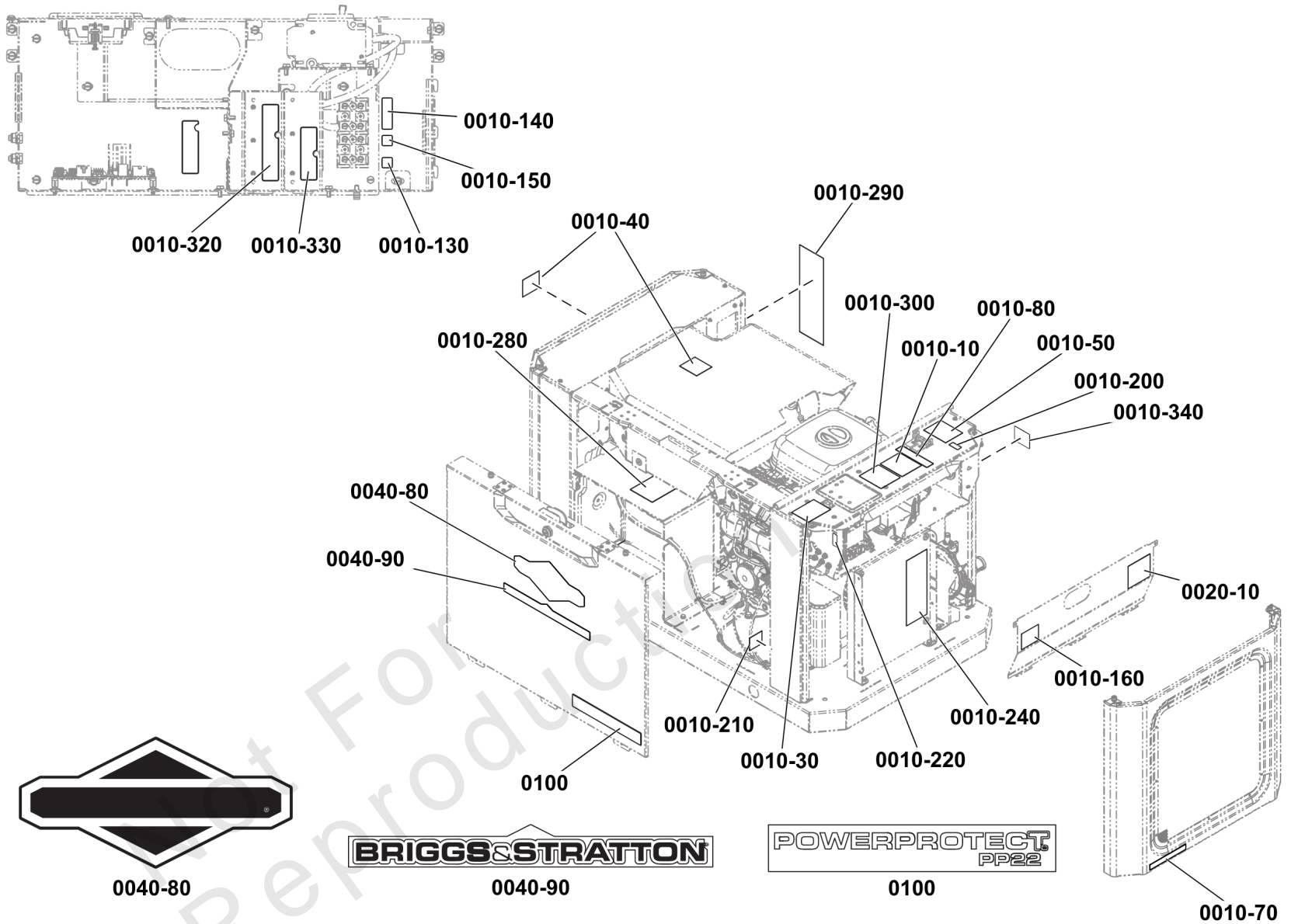

**0010**

**WARNING AVERTISSEMENT ADVERTENCIA**

Risk of electric shock, do not remove cover. No user serviceable parts inside. Refer servicing to qualified service personnel.

Risque de décharge électrique. Ne pas retirer le couvercle. Aucune pièce à entretenir par l'utilisateur à l'intérieur. Confier l'entretien à du personnel de service qualifié.

Riesgo de descarga eléctrica. No quite la cubierta. No hay partes que puedan ser reparadas por el usuario en el interior. Haga que personal calificado realice el servicio.

0010-10

**WARNING AVERTISSEMENT ADVERTENCIA**

To reduce the risk of fire, replace only with same type and rating of fuse.

Pour réduire le risque d'incendie, remplacez avec un fusible de même type et classification.

Para reducir el riesgo de incendio, reemplaza solamente con un fusible del mismo tipo y capacidad.

15AMP TYPE ATO

15 A TYPE ATO

0010-30

**WARNING AVERTISSEMENT ADVERTENCIA**

Hot surface could result in serious injury. Do not touch.

La surface chaude pourrait entraîner des blessures graves. Ne touchez pas.

La superficie caliente podría causar lesiones serias. No tocar.

0010-40

**WARNING AVERTISSEMENT ADVERTENCIA**

Generator starts automatically which could result in serious injury. Place switch in off and disconnect battery prior to servicing.

Le générateur démarre automatiquement, ce qui pourrait entraîner des blessures graves. Placez le commutateur en position arrêt et débranchez la batterie avant d'effectuer un entretien.

El generador arranca automáticamente, lo que podría causar lesiones serias. Coloque el interruptor en apagado y desconecte la batería antes de realizar algún servicio.

0010-300

**WARNING AVERTISSEMENT ADVERTENCIA**

Engine exhaust contains carbon monoxide, a poisonous gas that could kill you in minutes. You cannot smell it or see it. Install outdoors only. Install carbon monoxide alarms in home.

Hot surface could result in serious injury. Do not touch.

Engine exhaust could ignite combustibles resulting in death or serious injury. Exhaust side of weatherproof enclosure shall have 5 ft. (1.5M) min clearance from any structures, shrubs, trees or any vegetation.

This equipment may create sparks that could start fires around dry vegetation. A spark arrester may be required. Contact local fire agencies for regulations relating to fire prevention requirements.

L'échappement du moteur contient du monoxyde de carbone, un gaz toxique pouvant tuer en quelques minutes. Vous ne pouvez ni le sentir ni le voir. Installez à l'extérieur seulement. Installez les alarmes de monoxyde de carbone dans la maison.

La surface chaude pourrait entraîner des blessures graves. Ne touchez pas.

L'échappement du moteur peut enflammer les combustibles, ce qui peut provoquer des blessures graves, voire la mort. La partie pour l'échappement de l'encinte à l'épreuve des intempéries doit avoir un dégagement d'au moins 1,5 m (5 pi) de toutes structures, buissons, arbres ou autres végétaux.

Cet équipement peut produire des étincelles pouvant déclencher des incendies autour de la végétation sèche. Un pare-étincelles pourrait être nécessaire. Contactez les responsables locaux des règlements liés à la prévention des incendies.

Los gases de escape del motor contienen monóxido de carbono, un gas venenoso que podría matarlo en minutos. No puede verlo ni oírlo. Instale solamente en exteriores. Instale alarmas de monóxido de carbono en el hogar.

La superficie caliente podría causar lesiones serias. No tocar.

Los gases de escape del motor podrían incendiar materiales combustibles, lo que podría causar la muerte o lesiones serias. El lado de escape del gabinete impermeable debe tener un espacio libre de 5 pies (1,5 m) de distancia desde cualquier estructura, arbusto, árbol o cualquier vegetal.

Este equipo puede causar chispas que podrían iniciar incendios en vegetación seca. Podría requerirse un supresor de chispas. Póngase en contacto con las agencias locales de combate a incendios para consultar las regulaciones referentes a requisitos de prevención de incendios.

0010-220

**NOTICE AVIS AVISO**

**FUEL REQUIREMENTS**

Estimated generator fuel supply requirements for both natural gas and LP vapor.

**EXIGENCES EN MATIÈRE DE CARBURANT**

Approvisionnement approximatif en carburant pour le gaz naturel et le propane gazeux.

**REQUERIMIENTOS DE COMBUSTIBLE**

Requerimientos estimados de combustible para el generador para gas natural y gas LP.

kW	Natural Gas		LP Vapor	
	BTU/Hr	cu ft/hr	BTU/Hr	cu ft/hr
15kW	242,000	6.0	238,000	5.0
17kW	248,000	7.1	235,000	5.4
19kW	252,000	7.2	231,000	5.8
20kW	260,000	7.4	233,000	5.9
22kW	281,000	8.0	238,000	4.3
26kW	323,000	9.2	227,000	4.9

Fuel inlet pressure requirements at full load are:  
Les exigences de pression d'admission du carburant à plein rendement sont :  
Los requerimientos de presión de entrada de combustible a carga completa son de:

FUEL TYPE	Inches of WC	mm of WC
TYPE DE CARBURANT	pouces CE	mm de CE
TIPO DE COMBUSTIBLE	pulgadas de columna de agua	mm de columna de agua
Natural Gas	3.5-7	88-178
Gas naturel		
LP Vapor	11-14	279-356
Propane gazeux		
Gas LP		

0010-240

**WARNING AVERTISSEMENT ADVERTENCIA**

Risk of electric shock, do not remove cover. No user serviceable parts inside. Refer servicing to qualified service personnel.

Risque de décharge électrique. Ne pas retirer le couvercle. Aucune pièce à entretenir par l'utilisateur à l'intérieur. Confier l'entretien à du personnel de service qualifié.

Riesgo de descarga eléctrica. No quite la cubierta. No hay partes que puedan ser reparadas por el usuario en el interior. Haga que personal calificado realice el servicio.

0020-10

**WARNING AVERTISSEMENT ADVERTENCIA**

Hot surface could result in serious injury. Do not touch.

La surface chaude pourrait entraîner des blessures graves. Ne touchez pas.

La superficie caliente podría causar lesiones serias. No tocar.

0020-20

**WARNING AVERTISSEMENT ADVERTENCIA**

Hot surface could result in serious injury. Do not touch.

La surface chaude pourrait entraîner des blessures graves. Ne touchez pas.

La superficie caliente podría causar lesiones serias. No tocar.

0020-20

**WARNING AVERTISSEMENT ADVERTENCIA**

Hot surface could result in serious injury. Do not touch.

La surface chaude pourrait entraîner des blessures graves. Ne touchez pas.

La superficie caliente podría causar lesiones serias. No tocar.

0020-20

**WARNING AVERTISSEMENT ADVERTENCIA**

Explosion of battery gases could result in death or serious injury. Keep all sources of ignition away from battery. Battery contains acid which could result in blindness or severe burns. Avoid contact with acid.

L'explosion des gaz de la batterie peut provoquer des blessures graves, voire la mort. Tenez toutes les sources d'allumage éloignées de la batterie. La batterie contient de l'acide pouvant causer la cécité ou de sévères brûlures. Évitez le contact avec l'acide.

La explosión de los gases de la batería podría causar la muerte o lesiones serias. Mantenga todas las fuentes de ignición lejos de la batería. La batería contiene ácido que podría causar ceguera o quemaduras serias. Evite el contacto con el ácido.

0010-280

**CAUTION MISE EN GARDE PRECAUCION**

Connect output of generator to suitably rated transfer switch in accordance with the Canadian Electrical Code, Part 1.

Branchez le sortie de la génératrice à un commutateur on/off de classification convertible, selon le Code canadien de l'électricité, partie 1.

Conecte la salida del generador a un interruptor de transferencia de la capacidad adecuada de acuerdo con el Código Eléctrico Canadiense, Parte 1.

0010-290

**WARNING AVERTISSEMENT ADVERTENCIA**

Cancer and Reproductive Harm  
www.P65Warnings.ca.gov

Cancer et Problèmes de l'Appareil Reproducteur  
www.P65Warnings.ca.gov

Cáncer y Problemas Reproductivos  
www.P65Warnings.ca.gov

0010-160

**WARNING AVERTISSEMENT ADVERTENCIA**

Failure to read & follow Operator and installation manuals could result in death or serious injury.

No pas lire et respecter les manuels de l'utilisateur et d'installation pourrait entraîner des blessures graves ou la mort.

No leer y seguir las indicaciones de los manuales de operación e instalación podría causar la muerte o lesiones serias.

0010-50

**WARNING AVERTISSEMENT ADVERTENCIA**

Hot surface could result in serious injury. Do not touch.

La surface chaude pourrait entraîner des blessures graves. Ne touchez pas.

La superficie caliente podría causar lesiones serias. No tocar.

0020-10

**WARNING AVERTISSEMENT ADVERTENCIA**

Hot surface could result in serious injury. Do not touch.

La surface chaude pourrait entraîner des blessures graves. Ne touchez pas.

La superficie caliente podría causar lesiones serias. No tocar.

0020-20

**WARNING AVERTISSEMENT ADVERTENCIA**

Hot surface could result in serious injury. Do not touch.

La surface chaude pourrait entraîner des blessures graves. Ne touchez pas.

La superficie caliente podría causar lesiones serias. No tocar.

0020-20

**WARNING AVERTISSEMENT ADVERTENCIA**

Hot surface could result in serious injury. Do not touch.

La surface chaude pourrait entraîner des blessures graves. Ne touchez pas.

La superficie caliente podría causar lesiones serias. No tocar.

0020-20

**WARNING AVERTISSEMENT ADVERTENCIA**

Hot surface could result in serious injury. Do not touch.

La surface chaude pourrait entraîner des blessures graves. Ne touchez pas.

La superficie caliente podría causar lesiones serias. No tocar.

0020-20

**WARNING AVERTISSEMENT ADVERTENCIA**

Hot surface could result in serious injury. Do not touch.

La surface chaude pourrait entraîner des blessures graves. Ne touchez pas.

La superficie caliente podría causar lesiones serias. No tocar.

0020-20

**WARNING AVERTISSEMENT ADVERTENCIA**

Hot surface could result in serious injury. Do not touch.

La surface chaude pourrait entraîner des blessures graves. Ne touchez pas.

La superficie caliente podría causar lesiones serias. No tocar.

0020-20

**WARNING AVERTISSEMENT ADVERTENCIA**

Hot surface could result in serious injury. Do not touch.

La surface chaude pourrait entraîner des blessures graves. Ne touchez pas.

La superficie caliente podría causar lesiones serias. No tocar.

0020-20

**WARNING AVERTISSEMENT ADVERTENCIA**

Hot surface could result in serious injury. Do not touch.

La surface chaude pourrait entraîner des blessures graves. Ne touchez pas.

La superficie caliente podría causar lesiones serias. No tocar.

0020-20

**WARNING AVERTISSEMENT ADVERTENCIA**

Hot surface could result in serious injury. Do not touch.

La surface chaude pourrait entraîner des blessures graves. Ne touchez pas.

La superficie caliente podría causar lesiones serias. No tocar.

0020-20

**WARNING AVERTISSEMENT ADVERTENCIA**

Hot surface could result in serious injury. Do not touch.

La surface chaude pourrait entraîner des blessures graves. Ne touchez pas.

La superficie caliente podría causar lesiones serias. No tocar.

0020-20

**WARNING AVERTISSEMENT ADVERTENCIA**

Hot surface could result in serious injury. Do not touch.

La surface chaude pourrait entraîner des blessures graves. Ne touchez pas.

La superficie caliente podría causar lesiones serias. No tocar.

0020-20

**WARNING AVERTISSEMENT ADVERTENCIA**

Hot surface could result in serious injury. Do not touch.

La surface chaude pourrait entraîner des blessures graves. Ne touchez pas.

La superficie caliente podría causar lesiones serias. No tocar.

0020-20

**WARNING AVERTISSEMENT ADVERTENCIA**

Hot surface could result in serious injury. Do not touch.

La surface chaude pourrait entraîner des blessures graves. Ne touchez pas.

La superficie caliente podría causar lesiones serias. No tocar.

0020-20

**WARNING AVERTISSEMENT ADVERTENCIA**

Hot surface could result in serious injury. Do not touch.

La surface chaude pourrait entraîner des blessures graves. Ne touchez pas.

La superficie caliente podría causar lesiones serias. No tocar.

0020-20

**WARNING AVERTISSEMENT ADVERTENCIA**

Hot surface could result in serious injury. Do not touch.

La surface chaude pourrait entraîner des blessures graves. Ne touchez pas.

La superficie caliente podría causar lesiones serias. No tocar.

0020-20

**WARNING AVERTISSEMENT ADVERTENCIA**

Hot surface could result in serious injury. Do not touch.

La surface chaude pourrait entraîner des blessures graves. Ne touchez pas.

La superficie caliente podría causar lesiones serias. No tocar.

0020-20

**WARNING AVERTISSEMENT ADVERTENCIA**

Hot surface could result in serious injury. Do not touch.

La surface chaude pourrait entraîner des blessures graves. Ne touchez pas.

La superficie caliente podría causar lesiones serias. No tocar.

0020-20

**WARNING AVERTISSEMENT ADVERTENCIA**

Hot surface could result in serious injury. Do not touch.

La surface chaude pourrait entraîner des blessures graves. Ne touchez pas.

La superficie caliente podría causar lesiones serias. No tocar.

0020-20

**WARNING AVERTISSEMENT ADVERTENCIA**

Hot surface could result in serious injury. Do not touch.

La surface chaude pourrait entraîner des blessures graves. Ne touchez pas.

La superficie caliente podría causar lesiones serias. No tocar.

0020-20

**WARNING AVERTISSEMENT ADVERTENCIA**

Hot surface could result in serious injury. Do not touch.

La surface chaude pourrait entraîner des blessures graves. Ne touchez pas.

La superficie caliente podría causar lesiones serias. No tocar.

0020-20

**WARNING AVERTISSEMENT ADVERTENCIA**

Hot surface could result in serious injury. Do not touch.

La surface chaude pourrait entraîner des blessures graves. Ne touchez pas.

La superficie caliente podría causar lesiones serias. No tocar.

0020-20

**WARNING AVERTISSEMENT ADVERTENCIA**

Hot surface could result in serious injury. Do not touch.

La surface chaude pourrait entraîner des blessures graves. Ne touchez pas.

La superficie caliente podría causar lesiones serias. No tocar.

0020-20

**WARNING AVERTISSEMENT ADVERTENCIA**

Hot surface could result in serious injury. Do not touch.

La surface chaude pourrait entraîner des blessures graves. Ne touchez pas.

La superficie caliente podría causar lesiones serias. No tocar.

0020-20

**WARNING AVERTISSEMENT ADVERTENCIA**

Hot surface could result in serious injury. Do not touch.

La surface chaude pourrait entraîner des blessures graves. Ne touchez pas.

La superficie caliente podría causar lesiones serias. No tocar.

0020-20

**WARNING AVERTISSEMENT ADVERTENCIA**

Hot surface could result in serious injury. Do not touch.

La surface chaude pourrait entraîner des blessures graves. Ne touchez pas.

La superficie caliente podría causar lesiones serias. No tocar.

0020-20

**WARNING AVERTISSEMENT ADVERTENCIA**

Hot surface could result in serious injury. Do not touch.

La surface chaude pourrait entraîner des blessures graves. Ne touchez pas.

La superficie caliente podría causar lesiones serias. No tocar.

0020-20

**WARNING AVERTISSEMENT ADVERTENCIA**

Hot surface could result in serious injury. Do not touch.

La surface chaude pourrait entraîner des blessures graves. Ne touchez pas.

La superficie caliente podría causar lesiones serias. No tocar.

0020-20

**WARNING AVERTISSEMENT ADVERTENCIA**

Hot surface could result in serious injury. Do not touch.

La surface chaude pourrait entraîner des blessures graves. Ne touchez pas.

La superficie caliente podría causar lesiones serias. No tocar.

0020-20

**WARNING AVERTISSEMENT ADVERTENCIA**

Hot surface could result in serious injury. Do not touch.

La surface chaude pourrait entraîner des blessures graves. Ne touchez pas.

La superficie caliente podría causar lesiones serias. No tocar.

0020-20

**WARNING AVERTISSEMENT ADVERTENCIA**

Hot surface could result in serious injury. Do not touch.

La surface chaude pourrait entraîner des blessures graves. Ne touchez pas.

La superficie caliente podría causar lesiones serias. No tocar.

0020-20

**WARNING AVERTISSEMENT ADVERTENCIA**

Hot surface could result in serious injury. Do not touch.

La surface chaude pourrait entraîner des blessures graves. Ne touchez pas.

La superficie caliente podría causar lesiones serias. No tocar.

0020-20

**WARNING AVERTISSEMENT ADVERTENCIA**

Hot surface could result in serious injury. Do not touch.

La surface chaude pourrait entraîner des blessures graves. Ne touchez pas.

La superficie caliente podría causar lesiones serias. No tocar.

0020-20

**WARNING AVERTISSEMENT ADVERTENCIA**

Hot surface could result in serious injury. Do not touch.

La surface chaude pourrait entraîner des blessures graves. Ne touchez pas.

La superficie caliente podría causar lesiones serias. No tocar.

0020-20

**WARNING AVERTISSEMENT ADVERTENCIA**

Hot surface could result in serious injury. Do not touch.

La surface chaude pourrait entraîner des blessures graves. Ne touchez pas.

La superficie caliente podría causar lesiones serias. No tocar.

0020-20

**WARNING AVERTISSEMENT ADVERTENCIA**

Hot surface could result in serious injury. Do not touch.

La surface chaude pourrait entraîner des blessures graves. Ne touchez pas.

La superficie caliente podría causar lesiones serias. No tocar.

0020-20

**WARNING AVERTISSEMENT ADVERTENCIA**

Hot surface could result in serious injury. Do not touch.

La surface chaude pourrait entraîner des blessures graves. Ne touchez pas.

La superficie caliente podría causar lesiones serias. No tocar.

0020-20

**WARNING AVERTISSEMENT ADVERTENCIA**

Hot surface could result in serious injury. Do not touch.

La surface chaude pourrait entraîner des blessures graves. Ne touchez pas.

La superficie caliente podría causar lesiones serias. No tocar.

0020-20

**WARNING AVERTISSEMENT ADVERTENCIA**

Hot surface could result in serious injury. Do not touch.

La surface chaude pourrait entraîner des blessures graves. Ne touchez pas.

La superficie caliente podría causar lesiones serias. No tocar.

0020-20

**WARNING AVERTISSEMENT ADVERTENCIA**

Hot surface could result in serious injury. Do not touch.

La surface chaude pourrait entraîner des blessures graves. Ne touchez pas.

La superficie caliente podría causar lesiones serias. No tocar.

0020-20

**WARNING AVERTISSEMENT ADVERTENCIA**

Hot surface could result in serious injury. Do not touch.

La surface chaude pourrait entraîner des blessures graves. Ne touchez pas.

La superficie caliente podría causar lesiones serias. No tocar.

0020-20

**WARNING AVERTISSEMENT ADVERTENCIA**

Hot surface could result in serious injury. Do not touch.

La surface chaude pourrait entraîner des blessures graves. Ne touchez pas.

La superficie caliente podría causar lesiones serias. No tocar.

0020-20

**WARNING AVERTISSEMENT ADVERTENCIA**

Hot surface could result in serious injury. Do not touch.

La surface chaude pourrait entraîner des blessures graves. Ne touchez pas.

La superficie caliente podría causar lesiones serias. No tocar.

0020-20

**WARNING AVERTISSEMENT ADVERTENCIA**

Hot surface could result in serious injury. Do not touch.

La surface chaude pourrait entraîner des blessures graves. Ne touchez pas.

La superficie caliente podría causar lesiones serias. No tocar.

0020-20

**WARNING AVERTISSEMENT ADVERTENCIA**

Hot surface could result in serious injury. Do not touch.

La surface chaude pourrait entraîner des blessures graves. Ne touchez pas.

La superficie caliente podría causar lesiones serias. No tocar.

0020-20

**WARNING AVERTISSEMENT ADVERTENCIA**

Hot surface could result in serious injury. Do not touch.

La surface chaude pourrait entraîner des blessures graves. Ne touchez pas.

La superficie caliente podría causar lesiones serias. No tocar.

0020-20

**WARNING AVERTISSEMENT ADVERTENCIA**

Hot surface could result in serious injury. Do not touch.

La surface chaude pourrait entraîner des blessures graves. Ne touchez pas.

La superficie caliente podría causar lesiones serias. No tocar.

0020-20

**WARNING AVERTISSEMENT ADVERTENCIA**

Hot surface could result in serious injury. Do not touch.

La surface chaude pourrait entraîner des blessures graves. Ne touchez pas.

La superficie caliente podría causar lesiones serias. No tocar.

0020-20

**WARNING AVERTISSEMENT ADVERTENCIA**

Hot surface could result in serious injury. Do not touch.

La surface chaude pourrait entraîner des blessures graves. Ne touchez pas.

La superficie caliente podría causar lesiones serias. No tocar.

0020-20

**WARNING AVERTISSEMENT ADVERTENCIA**

Hot surface could result in serious injury. Do not touch.

La surface chaude pourrait entraîner des blessures graves. Ne touchez pas.

La superficie caliente podría causar lesiones serias. No tocar.

0020-20

**WARNING AVERTISSEMENT ADVERTENCIA**

Hot surface could result in serious injury. Do not touch.

La surface chaude pourrait entraîner des blessures graves. Ne touchez pas.

La superficie caliente podría causar lesiones serias. No tocar.

0020-20

**WARNING AVERTISSEMENT ADVERTENCIA**

Hot surface could result in serious injury. Do not touch.

La surface chaude pourrait entraîner des blessures graves. Ne touchez pas.

La superficie caliente podría causar lesiones serias. No tocar.

0020-20

**WARNING AVERTISSEMENT ADVERTENCIA**

Hot surface could result in serious injury. Do not touch.

La surface chaude pourrait entraîner des blessures graves. Ne touchez pas.

La superficie caliente podría causar lesiones serias. No tocar.

0020-20

**WARNING AVERTISSEMENT ADVERTENCIA**

Hot surface could result in serious injury. Do not touch.

La surface chaude pourrait entraîner des blessures graves. Ne touchez pas.

La superficie caliente podría causar lesiones serias. No tocar.

0020-20

**WARNING AVERTISSEMENT ADVERTENCIA**

Hot surface could result in serious injury. Do not touch.

La surface chaude pourrait entraîner des blessures graves. Ne touchez pas.

La superficie caliente podría causar lesiones serias. No tocar.

0020-20

**WARNING AVERTISSEMENT ADVERTENCIA**

Hot surface could result in serious injury. Do not touch.

La surface chaude pourrait entraîner des blessures graves. Ne touchez pas.

La superficie caliente podría causar lesiones serias. No tocar.

0020-20

**WARNING AVERTISSEMENT ADVERTENCIA**

Hot surface could result in serious injury. Do not touch.

La surface chaude pourrait entraîner des blessures graves. Ne touchez pas.

La superficie caliente podría causar lesiones serias. No tocar.

0020-20

**WARNING AVERTISSEMENT ADVERTENCIA**

Hot surface could result in serious injury. Do not touch.

La surface chaude pourrait entraîner des blessures graves. Ne touchez pas.

La superficie caliente podría causar lesiones serias. No tocar.

0020-20

**WARNING AVERTISSEMENT ADVERTENCIA**

Hot surface could result in serious injury. Do not touch.

La surface chaude pourrait entraîner des blessures graves. Ne touchez pas.

La superficie caliente podría causar lesiones serias. No tocar.

0020-20

**WARNING AVERTISSEMENT ADVERTENCIA**

Hot surface could result in serious injury. Do not touch.

La surface chaude pourrait entraîner des blessures graves. Ne touchez pas.

La superficie caliente podría causar lesiones serias. No tocar.

0020-20

**WARNING AVERTISSEMENT ADVERTENCIA**

Hot surface could result in serious injury. Do not touch.

La surface chaude pourrait entraîner des blessures graves. Ne touchez pas.

La superficie caliente podría causar lesiones serias. No tocar.

0020-20

**WARNING AVERTISSEMENT ADVERTENCIA**

Hot surface could result in serious injury. Do not touch.

La surface chaude pourrait entraîner des blessures graves. Ne touchez pas.

La superficie caliente podría causar lesiones serias. No tocar.

0020-20

**WARNING AVERTISSEMENT ADVERTENCIA**

Hot surface could result in serious injury. Do not touch.

La surface chaude pourrait entraîner des blessures graves. Ne touchez pas.

La superficie caliente podría causar lesiones serias. No tocar.

0020-20

**WARNING AVERTISSEMENT ADVERTENCIA**

Hot surface could result in serious injury. Do not touch.

La surface chaude pourrait entraîner des blessures graves. Ne touchez pas.

La superficie caliente podría causar lesiones serias. No tocar.

0020-20

**WARNING AVERTISSEMENT ADVERTENCIA**

Hot surface could result in serious injury. Do not touch.

La surface chaude pourrait entraîner des blessures graves. Ne touchez pas.

La superficie caliente podría causar lesiones serias. No tocar.

0020-20

**WARNING AVERTISSEMENT ADVERTENCIA**

Hot surface could result in serious injury. Do not touch.

La surface chaude pourrait entraîner des blessures graves. Ne touchez pas.

La superficie caliente podría causar lesiones serias. No tocar.

0020-20

**WARNING AVERTISSEMENT ADVERTENCIA**

Hot surface could result in serious injury. Do not touch.

La surface chaude pourrait entraîner des blessures graves. Ne touchez pas.

La superficie caliente podría causar lesiones serias. No tocar.

0020-20

**WARNING AVERTISSEMENT ADVERTENCIA**

Hot surface could result in serious injury. Do not touch.

La surface chaude pourrait entraîner des blessures graves. Ne touchez pas.

La superficie caliente podría causar lesiones serias. No tocar.

0020-20

**WARNING AVERTISSEMENT ADVERTENCIA**

Hot surface could result in serious injury. Do not touch.

La surface chaude pourrait entraîner des blessures graves. Ne touchez pas.

La superficie caliente podría causar lesiones serias. No tocar.

0020-20

**WARNING AVERTISSEMENT ADVERTENCIA**

Hot surface could result in serious injury. Do not touch.

La surface chaude pourrait entraîner des blessures graves. Ne touchez pas.

La superficie caliente podría causar lesiones serias. No tocar.

0020-20

**WARNING AVERTISSEMENT ADVERTENCIA**

Hot surface could result in serious injury.

## Decals Group

REF NO	PART NO	QTY	DESCRIPTION
0010	84010842	1	DECAL, Warning, Sheet -(Includes items 0010-0010 thru 0010-0340)
0010-10	-----	1	DECAL-WARNING, SHOCK
0010-30	-----	1	DECAL-WARNING, FUSE
0010-40	-----	2	DECAL-WARNING, HOT SURFACE
0010-50	-----	1	DECAL, Warning, Manual
0010-70	-----	1	DECAL-RAINPROOF ENCLOSURE
0010-80	-----	1	DECAL-DISCONNECT
0010-130	-----	1	DECAL, Neutral
0010-140	-----	1	DECAL, L1/L2
0010-150	-----	1	DECAL, Ground
0010-160	-----	1	DECAL, Warning -(The installation of this decal is required for units manufactured after 08/30/2018 and sold in the state of California.)
0010-200	-----	1	DECAL, FCC, ICES-3
0010-210	-----	1	DECAL, MOR, AUBURN
0010-220	-----	1	DECAL, Fuel Selection
0010-240	-----	1	DECAL, Notice Fuel Requirements
0010-280	-----	1	DECAL, Warning, Battery
0010-290	-----	1	DECAL, Warning, Exhaust
0010-300	-----	1	DECAL, Warning, Auto Start
0010-320	-----	1	DECAL, Terminal Strip
0010-330	-----	1	DECAL, Terminal Strip
0010-340	-----	1	DECAL, Emergency Shutdown
0020	84007020	1	DECAL SHEET - WARNINGS -(Includes items 0540-10, 0540-20)
0020-10	-----	1	DECAL-WARNING, SHOCK
0020-20	-----	3	DECAL-WARNING, HOT SURFACE
0040-80	-----	1	DECAL
0040-90	-----	1	DECAL
0100	-----	1	DECAL, Brand, PP22

# Enclosure Group

Note: Unless noted otherwise, use the standard torque specifications

Mfg. No: 040786-00

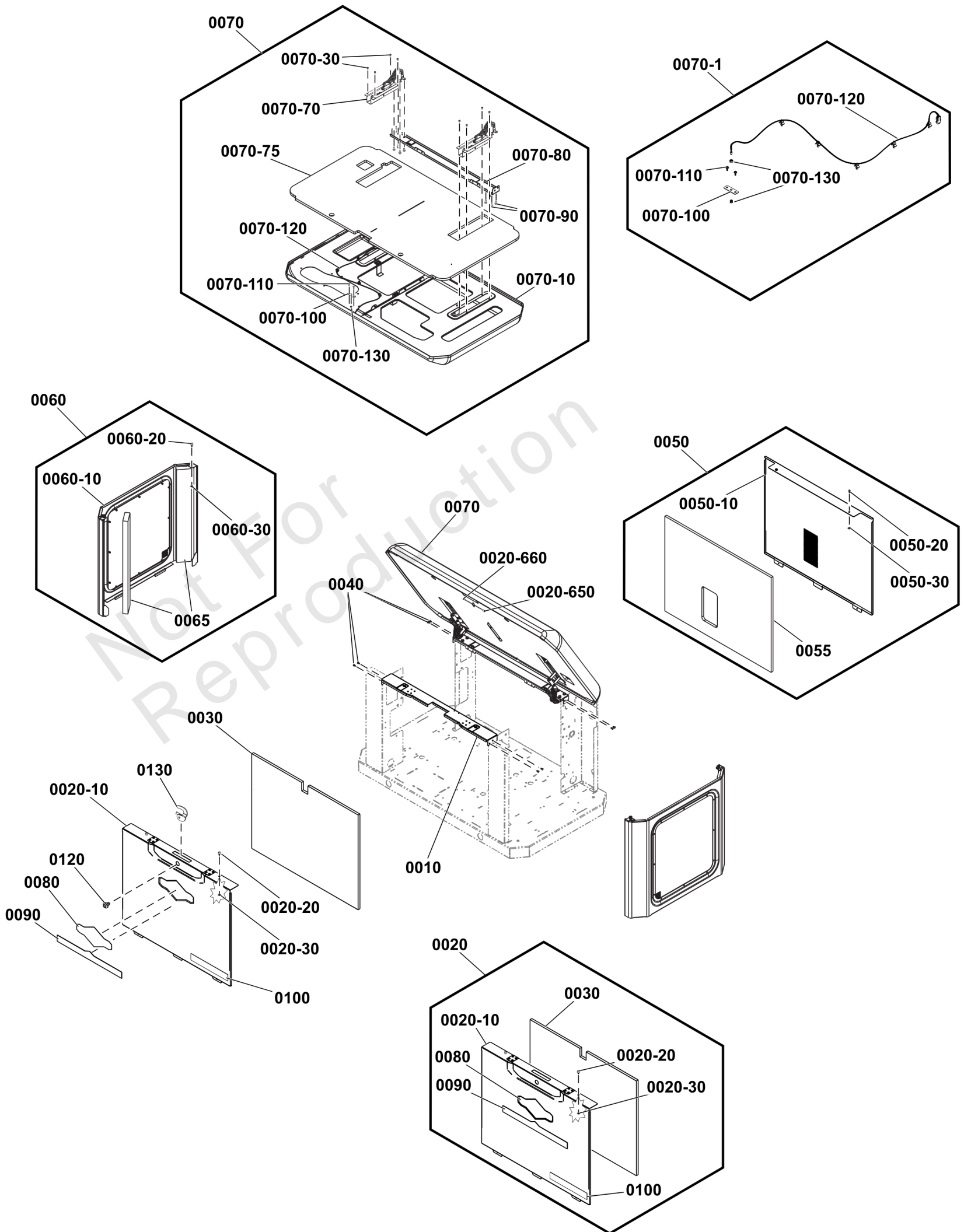

## Enclosure Group

REF NO	PART NO	QTY	DESCRIPTION
0010	84006384	1	RAIL, Front
0020	6936	1	ASSEMBLY, Panel, Front -(Incl. Ref. Nos. 0020-10, 0020-20, 0020-30, 0030, 0080, 0090, 0100)
0020-10	-----	1	PANEL, Front
0020-20	-----	2	SCREW, Captive
0020-30	-----	2	RETAINER
0030	-----	1	INSULATION
0080	-----	1	DECAL
0090	-----	1	DECAL
0100	-----	1	DECAL, Brand, PP22
0020-650	84007139	1	BARREL, Binding
0020-660	36901GS	1	PPHMS, 6-32 X 3/8
0040	84006392	8	SCREW, #10-32 X 3/8
0050	6858	1	ASSEMBLY, Panel, Back -(Incl. Ref. Nos. 0050, 0050-20, 0050-30, 0055)
0050-10	-----	1	PANEL, Back
0050-20	-----	2	SCREW, Captive
0050-30	-----	2	RETAINER
0055	-----	1	INSULATION
0060	6859	2	ASSEMBLY, Panel, End -(Incl. Ref. Nos. 0060-10, 0060-20, 0060-30, 0065)
0060-10	-----	1	PANEL, End
0060-20	-----	2	SCREW, Captive
0060-30	-----	2	RETAINER
0065	-----	2	INSULATION
0070	6860	1	ASSEMBLY, Roof -(Incl. Ref. Nos. 0070-10, 0070-30, 0070-70, 0070-75, 0070-80, 0070-90, 0070-100, 0070-110, 0070-120, 0070-130)
0070-10	-----	1	PANEL, Roof
0070-30	-----	8	RIVET, Blind, 1/8 X 5/16
0070-70	-----	2	HINGE, Roof
0070-75	-----	1	INSULATION
0070-80	-----	1	SUPPORT, Rail
0070-90	704130	8	SCREW, HEX, 1/4-20X.5
0070-100	-----	1	PLATE, Mount
0070-110	205947GS	2	SCREW, Trilobular, #10-32 x 3/4
0070-120	-----	1	HARNESS, Wire
0070-130	-----	1	CLIP, Mounting
0070-1	84008085	1	KIT, Light -(Incl. Ref. Nos. 0070-100, 0070-110, 0070-120, 0070-130)
0070-100	-----	1	PLATE, Mount
0070-110	205947GS	2	SCREW, Trilobular, #10-32 x 3/4
0070-120	-----	1	HARNESS, Wire
0070-130	-----	1	CLIP, Mounting
0080	-----	1	DECAL
0090	-----	1	DECAL
0100	-----	1	DECAL, Brand, PP22
0120	314619GS	1	LATCH
0130	84006387	1	LATCH, Arm

# Fuel, Duct & Support Group

Note: Unless noted otherwise, use the standard torque specifications

Mfg. No: 040786-00

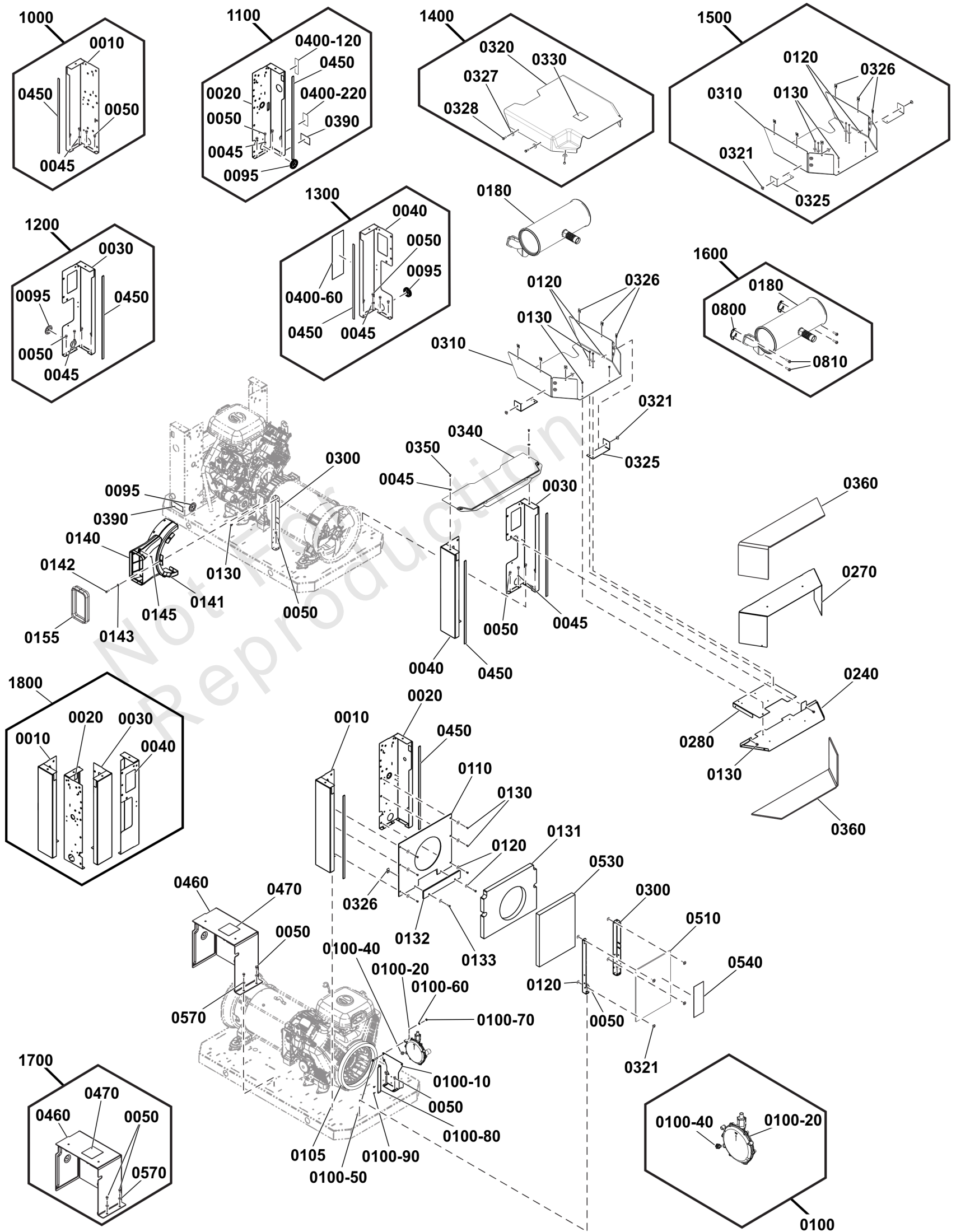

## Fuel, Duct & Support Group

REF NO	PART NO	QTY	DESCRIPTION
0045	26850GS	6	WASHER, Ext. M6 - 1/4" Shakeproof
0050	704130	23	SCREW, HEX, 1/4-20X.5
0100	84006385	1	FUEL REGULATOR ASSEMBLY -(Includes Ref. Nos. 0100-20, 0100-40)
0100-10	706379	1	BRACKET
0100-20	-----	1	FUEL REGULATOR ASSEMBLY
0100-40	318002GS	1	FITTING
0100-50	38750GS	2	HHCS, M6 - 1.0 x 30
0100-60	22097GS	2	WASHER
0100-70	49813GS	2	NUT, Hex, M6 - 1.0
0100-80	-----	1	BRACKET
0100-90	194561GS	2	HHS, Trilobular, #10-32 x 3/8
0105	-----	1	SEAL, Ring
0110	84006038	1	PANEL, Intake
0120	-----	25	WASHER, Flat, #10, Fender -(*See footnote)
0130	194561GS	19	HHS, Trilobular, #10-32 x 3/8
0131	-----	1	INSULATION
0132	-----	1	INSULATION
0133	22473GS	2	FLAT WASHER, M6 - 1/4"
0140	-----	1	DUCT, Left
0141	-----	1	DUCT, Right
0142	52618GS	5	SCREW, M5 x 0.8 x 12
0143	23897GS	5	WASHER, Flat, #10 - M5
0145	-----	3	SCREW, #8-18 X 3/8
0155	-----	1	SEAL
0180	84007030	1	KIT, Muffler
0240	-----	1	PANEL, Bottom
0270	-----	1	PANEL, Top
0280	-----	1	SUPPORT
0300	-----	3	SUPPORT
0321	-----	21	RIVET, BLIND, 3/16 X 5/8
0325	-----	2	BRACKET, Muffler
0326	-----	8	NUT, Clip
0327	71693GS	6	WASHER, Fender
0328	5025010X6	8	BOLT, 1/4"-20 X 3/4" GD5 YZ
0340	84006316	1	PANEL
0350	84006392	2	SCREW, #10-32 X 3/8
0360	-----	2	INSULATION
0450	-----	4	SEAL, Foam
0460	-----	1	PANEL, Battery Box
0510	-----	1	INSULATION
0530	-----	1	INSULATION
0540	-----	1	DECAL, Notice Fuel Requirements -(Part information located in Decals Group.)
0570	-----	2	WASHER
1000	84007045	1	KIT, Support, Right Front -(Includes Ref. Nos. 0010, 0045, 0050, 0450)
0010	-----	1	SUPPORT, Right Front

### Footnotes:

\* Items without part numbers are common fasteners. Purchase locally.



## Fuel, Duct & Support Group

REF NO	PART NO	QTY	DESCRIPTION
0045	26850GS	1	WASHER, Ext. M6 - 1/4" Shakeproof
0050	704130	4	SCREW, HEX, 1/4-20X.5
0450	-----	1	SEAL, Foam
1100	84007046	1	KIT, Support, Right Back -(Includes Ref. Nos. 0020, 0045, 0050, 0390, 0400-120, 0400-220, 0450)
0010	-----	1	SUPPORT, Right Back
0045	26850GS	1	WASHER, Ext. M6 - 1/4" Shakeproof
0050	704130	4	SCREW, HEX, 1/4-20X.5
0095	-----	1	GROMMET
0390	-----	1	DECAL, SWRI
0400-120	-----	1	DECAL, External Power Switch -(Part information located in Decals Group.)
0400-220	-----	1	DECAL, Fuel Selection -(Part information located in Decals Group.)
0450	-----	1	SEAL, Foam
1200	84007047	1	KIT, Support, Left Front -(Includes Ref. Nos. 0030, 0045, 0050, 0095, 0450)
0030	-----	1	SUPPORT, Left Front
0045	26850GS	1	WASHER, Ext. M6 - 1/4" Shakeproof
0050	704130	4	SCREW, HEX, 1/4-20X.5
0095	-----	1	GROMMET
0450	-----	1	SEAL, Foam
1300	84007048	1	KIT, Support, Left Back -(Includes Ref. Nos. 0040, 0045, 0050, 0095, 0400-60, 0450)
0040	-----	1	SUPPORT, Left Back
0045	26850GS	1	WASHER, Ext. M6 - 1/4" Shakeproof
0050	704130	4	SCREW, HEX, 1/4-20X.5
0095	-----	1	GROMMET
0400-60	-----	1	DECAL-WARNING, EXHAUST -(Part information located in Decals Group.)
0450	-----	1	SEAL, Foam
1400	84007029	1	KIT, Muffler Box, Top -(Includes Ref. Nos. 0320, 0327, 0328, 0330)
0320	-----	1	MUFFLER BOX, Top
0327	71693GS	6	WASHER, Fender
0328	22287GS	6	SCREW, 1/4" - 20 x 3/4"
0330	-----	1	DECAL-WARNING, HOT SURFACE -(Part information located in Decals Group.)
1500	84007080	1	KIT, Muffler Box, Bottom -(Includes Ref. Nos. 0120, 0130, 0310, 0321, 0325, 0326)
0120	-----	10	WASHER, Flat, #10, Fender
0130	194561	6	HHS,TRILOBULAR, #10-3
0310	-----	1	MUFFLER BOX, Bottom
0321	-----	6	RIVET, BLIND, 3/16 X 5/8
0325	-----	2	BRACKET, Muffler
0326	-----	6	NUT, Clip
1600	84007030	1	KIT, Muffler -(Includes Ref. Nos. 0180, 0800, 0810)
0180	-----	1	MUFFLER
0800	809872	2	GASKET, Exhaust
0810	846149	4	SCREW

### Footnotes:

\* Items without part numbers are common fasteners. Purchase locally.



## Fuel, Duct & Support Group

REF NO	PART NO	QTY	DESCRIPTION
1700	84007032	1	KIT, Battery Box -(Includes Ref. Nos. 0050, 0460, 0470)
0050	704130	2	SCREW, HEX, 1/4-20X.5
0460	-----	1	PANEL, Battery Box
0470	-----	1	DECAL, Warning, Battery -(Part information located in Decals Group.)
0570	-----	2	WASHER
1800	6856	1	ENCLOSURE, Bulkhead -(Includes Ref. Nos. 0010, 0020, 0030, 0040)
0010	-----	1	SUPPORT, Right Back
0020	-----	1	SUPPORT, Left Back
0030	-----	1	SUPPORT, Left Front
0040	-----	1	SUPPORT, Right Front

Not For  
Reproduction

---

**Footnotes:**

\* Items without part numbers are common fasteners. Purchase locally.

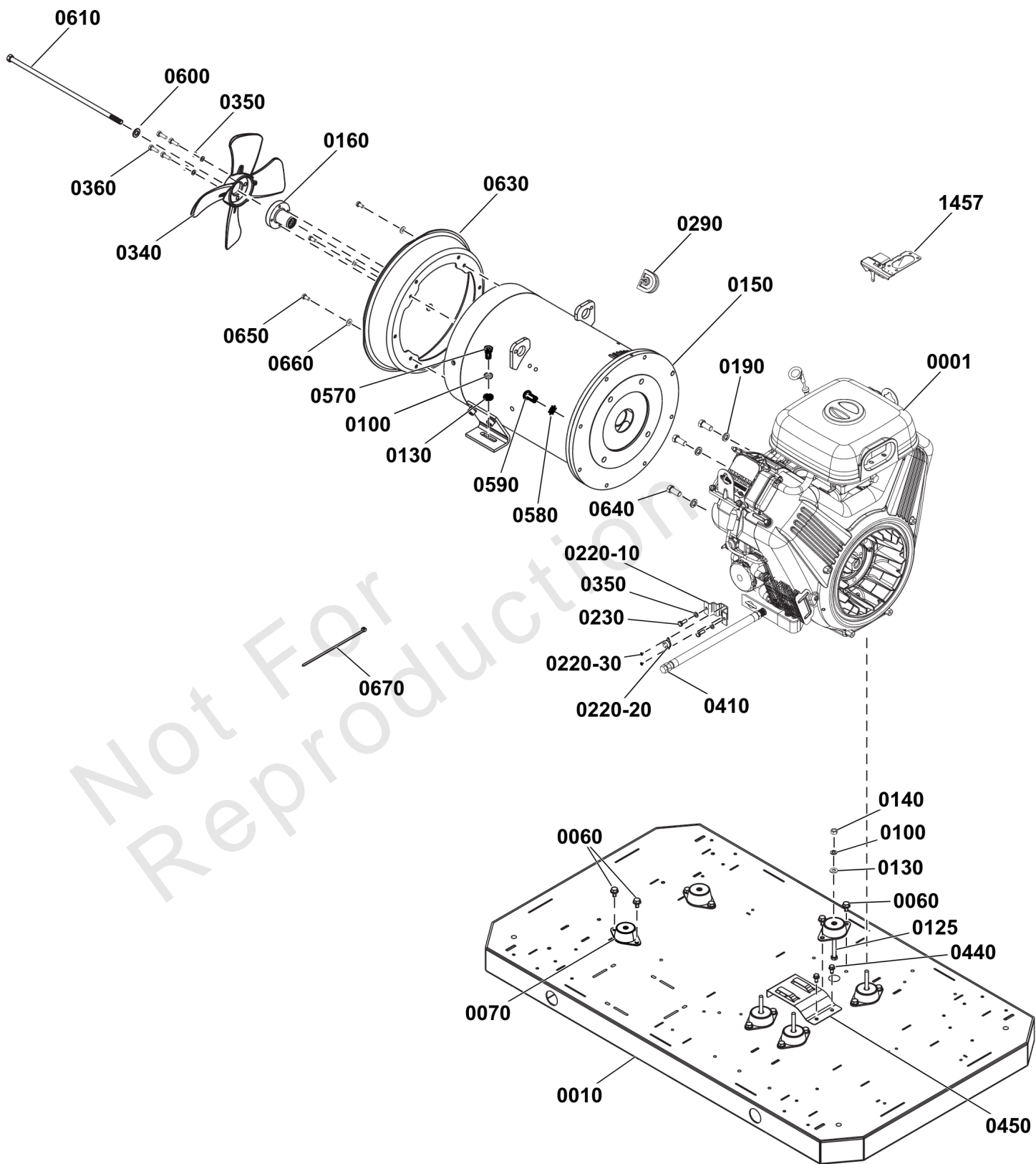

## Power Group

REF NO	PART NO	QTY	DESCRIPTION
0001	61H3750001E1	1	Replacement Engine -(**See footnote)
0010	-----	1	BASE
0060	24910GS	12	CAPSCREW, Hex Head, Trilobular, 5/16, 18 x 1/2
0070	84007023	6	MOUNT, Vibration
0100	22129GS	6	WASHER, Lock
0125	-----	4	*CAPSCREW, Hex Head, 5/16-18 x 2-1/2 -(*See footnote)
0130	5025155SM	6	WASHER, 5/16
0140	22259GS	4	NUT, 5/16 - 18
0150	84010874	1	ALTERNATOR
0160	84007022	1	HUB, Fan
0190	-----	4	*WASHER, Lock, 7/16 -(*See footnote)
0220-10	313561GS	1	PLATE, Temp Switch
0220-20	204426GS	1	SWITCH, Temperature
0220-30	708730	2	SCREW
0230	47411GS	2	SCREW
0290	315440GS	1	GROMMET
0340	84006018	1	FAN
0350	22097GS	6	WASHER
0360	5025010X6SM	4	BOLT, 1/4-20 X 3/4" G
0410	5048681SM	1	HOSE, OIL DRAIN
0440	704130	2	SCREW, HEX, 1/4-20X.5
0450	-----	1	BRACKET, Heater
0570	5025011X6	2	BOLT, 5/16-18 X 3/4 GD5
0580	193686	8	WSHR, M10, SHKPRF, EXT
0590	-----	8	*SCREW, M10 X 25 -(*See footnote)
0600	203200	1	WASHER, 3/8" SAE
0610	315203GS	1	BOLT
0630	84006017	1	SHROUD, Fan
0640	2820676SM	4	CAPSCREW-HEX HD 7/16-
0650	807435	6	SCREW
0660	22473GS	6	FLAT WASHER, M6 - 1/4"
0670	29333AGS	1	TIEWRAP, 7 LG BLK
1457	-----	1	MOTOR, Stepper -(Refer To Your Engine Model's Parts Manual)

### Footnotes:

\* Items without part numbers are common fasteners. Purchase locally.

\*\* To verify your specific engine model, please reference the ID Tag located on your engine. See your local Briggs & Stratton distributor for parts and service.



# 6845-00 - Fuel Regulator Heater

Not For  
Reproduction

# Fuel Regulator Heater

Note: Unless noted otherwise, use the standard torque specifications

Mfg. No: 6845-00

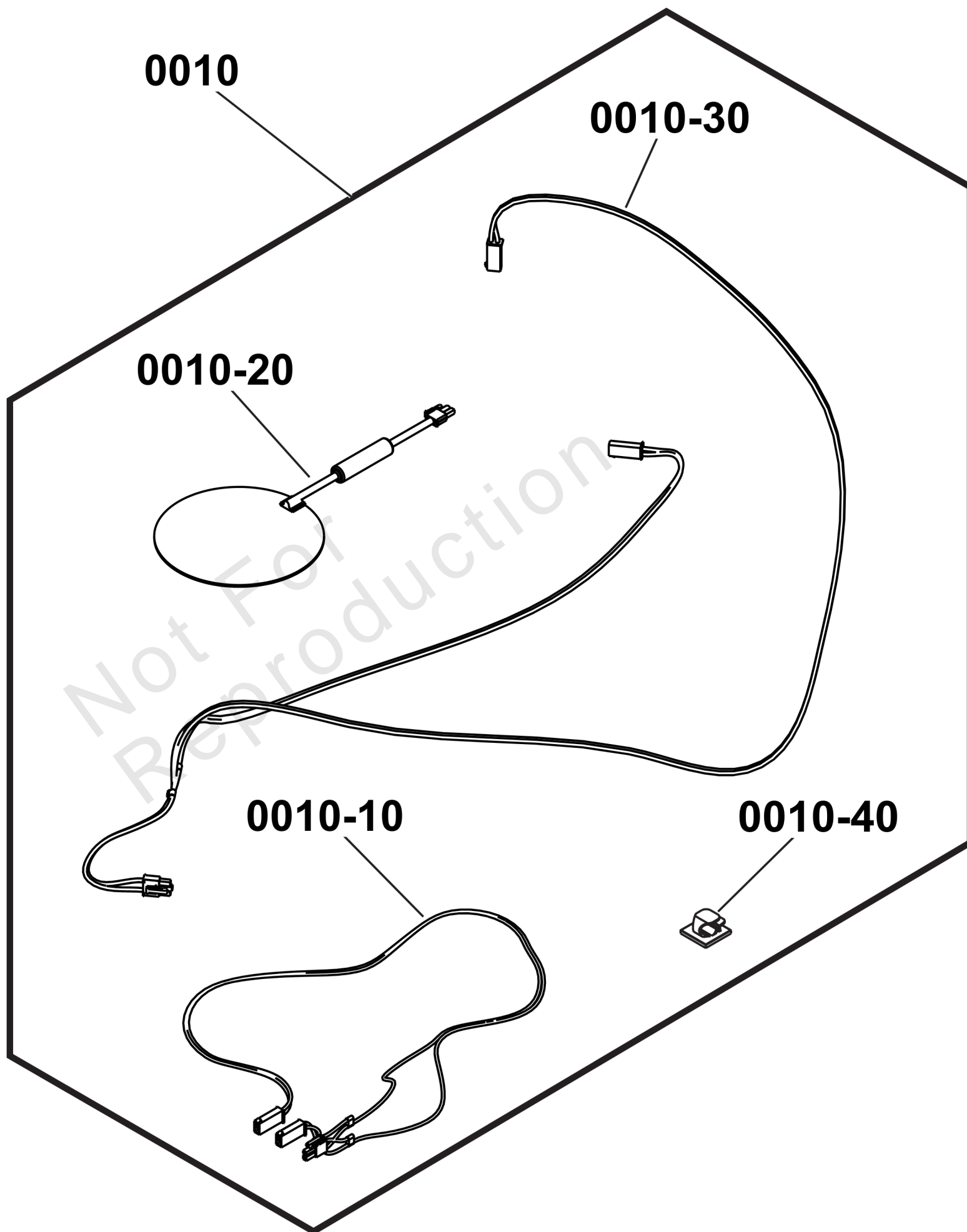

## ***Fuel Regulator Heater***

<b>REF NO</b>	<b>PART NO</b>	<b>QTY</b>	<b>DESCRIPTION</b>
0010	6845	1	HEATER, Fuel Regulator
0010-10	-----	1	HARNESS, Wire
0010-20	-----	1	HEATER, Fuel Regulator
0010-30	-----	1	HARNESS, Cold Weather
0010-40	-----	1	CLIP, LTCHNG

Not For Reproduction



# 6840-00 - Oil Sump Warmer

Not For  
Reproduction

# Oil Sump Warmer

Note: Unless noted otherwise, use the standard torque specifications

Mfg. No: 6840-00

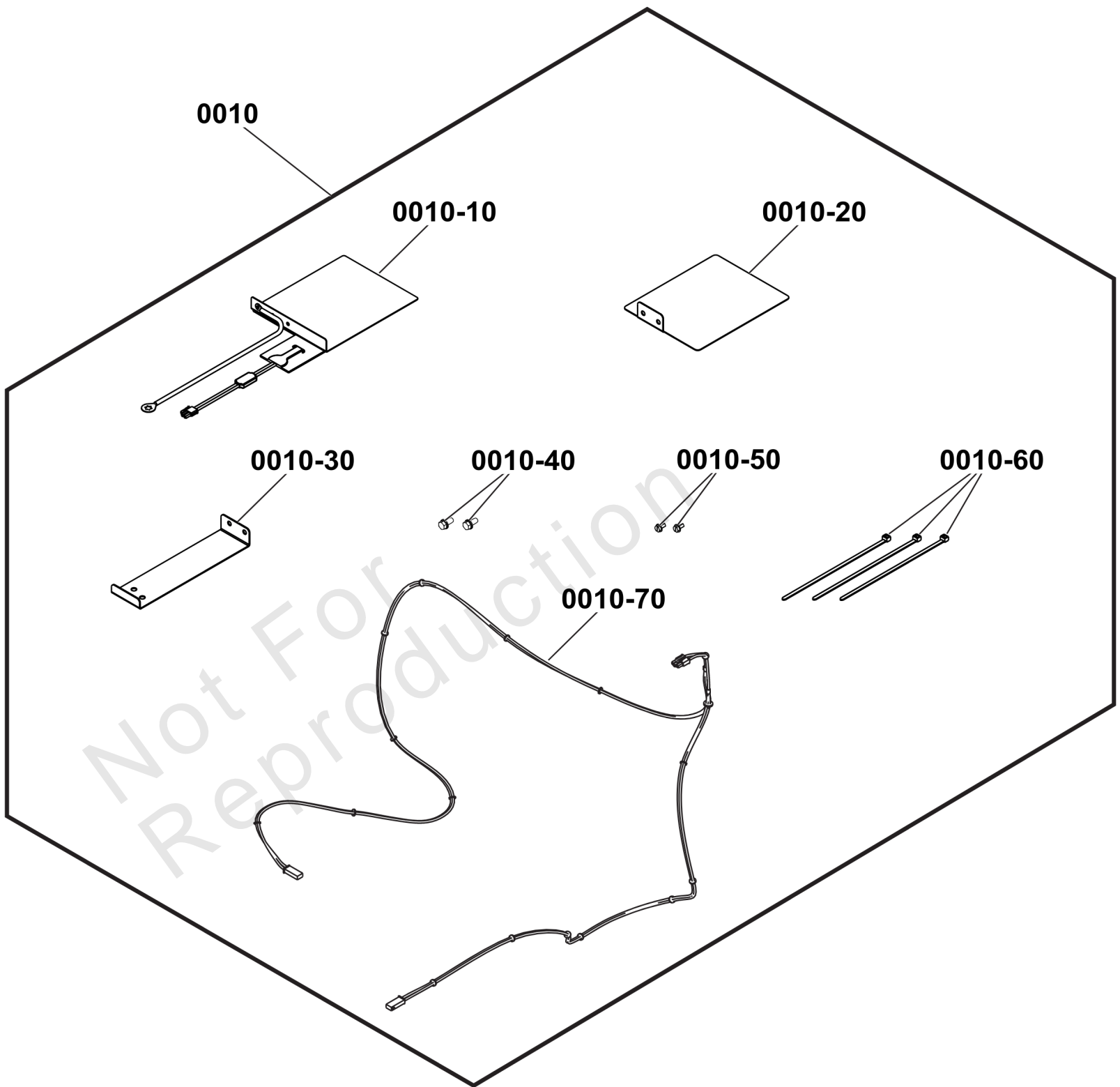

## Oil Sump Warmer

REF NO	PART NO	QTY	DESCRIPTION
0010	6840		KIT, Oil Sump Warmer -(Incl. Ref. Nos. 0010-10, 0010-20, 0010-30, 0010-40, 0010-50, 0010-60, 0010-70)
0010-10	314941GS	1	PLATE, Warmer
0010-20	-----	1	PLATE, Warmer
0010-30	-----	1	BRACKET, Guide, Warmer
0010-40	704130	2	SCREW, HEX, 1/4-20X.5
0010-50	194561GS	2	HHS, Trilobular, #10-32 x 3/8
0010-60	29333AGS	3	TIEWRAP, 7 LG BLK
0010-70	84007199	1	HARNESS, Cold Weather

Not For Reproduction

# 6869-00 - Battery Warmer



Not For  
Reproduction

**Battery Warmer**

Note: Unless noted otherwise, use the standard torque specifications

Mfg. No: 6869-00

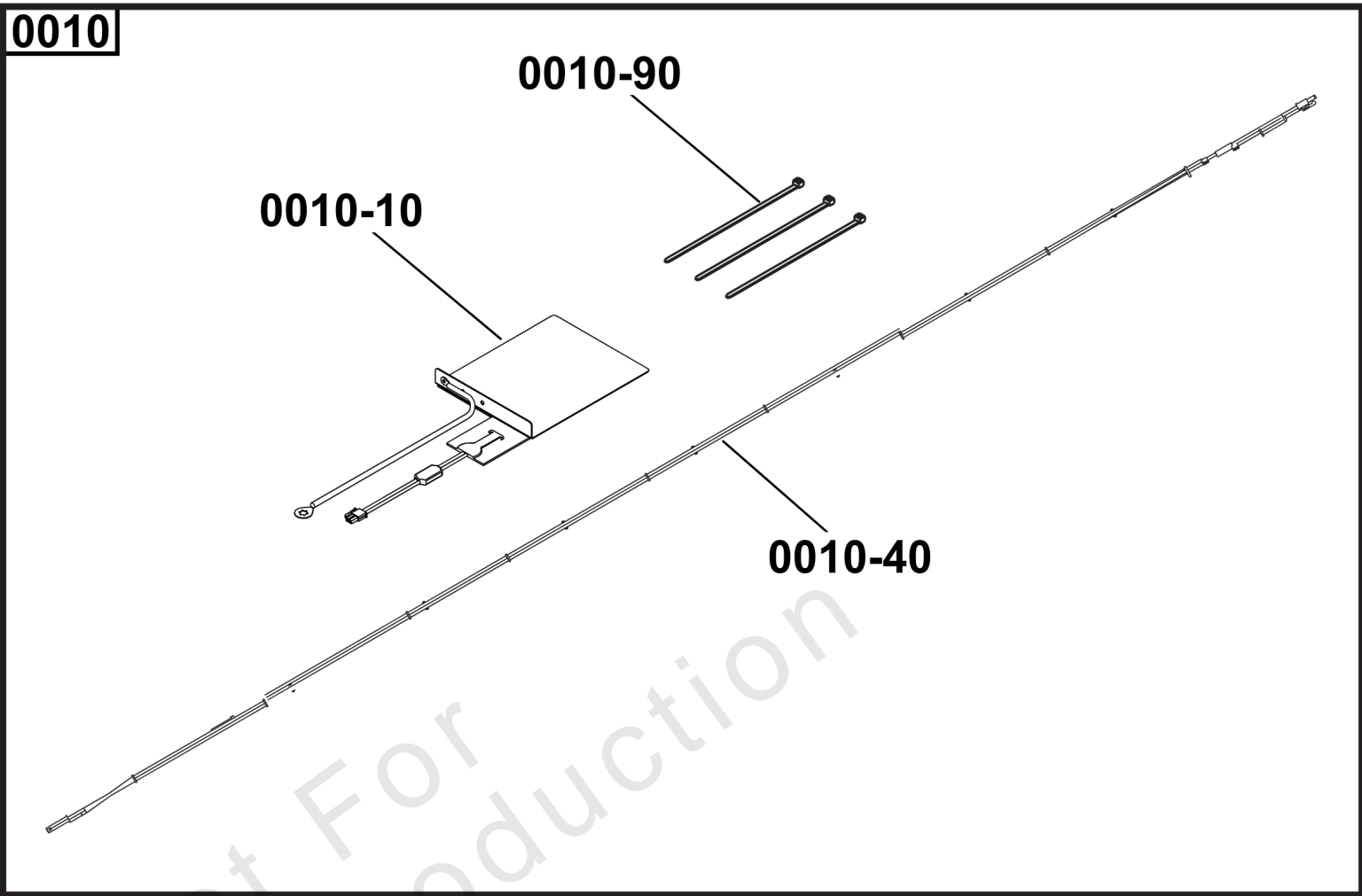

## ***Battery Warmer***

---

<b>REF NO</b>	<b>PART NO</b>	<b>QTY</b>	<b>DESCRIPTION</b>
0010	6869	1	WARMER, Battery
0010-10	314941GS	1	PLATE, Warmer
0010-40	84007199	1	HARNESS, Cold Weather
0010-90	29333AGS	3	TIEWRAP, 7 LG BLK

Not For Reproduction



Not For  
Reproduction

# Maintenance

Note: Unless noted otherwise, use the standard torque specifications

Mfg. No: 6872-00

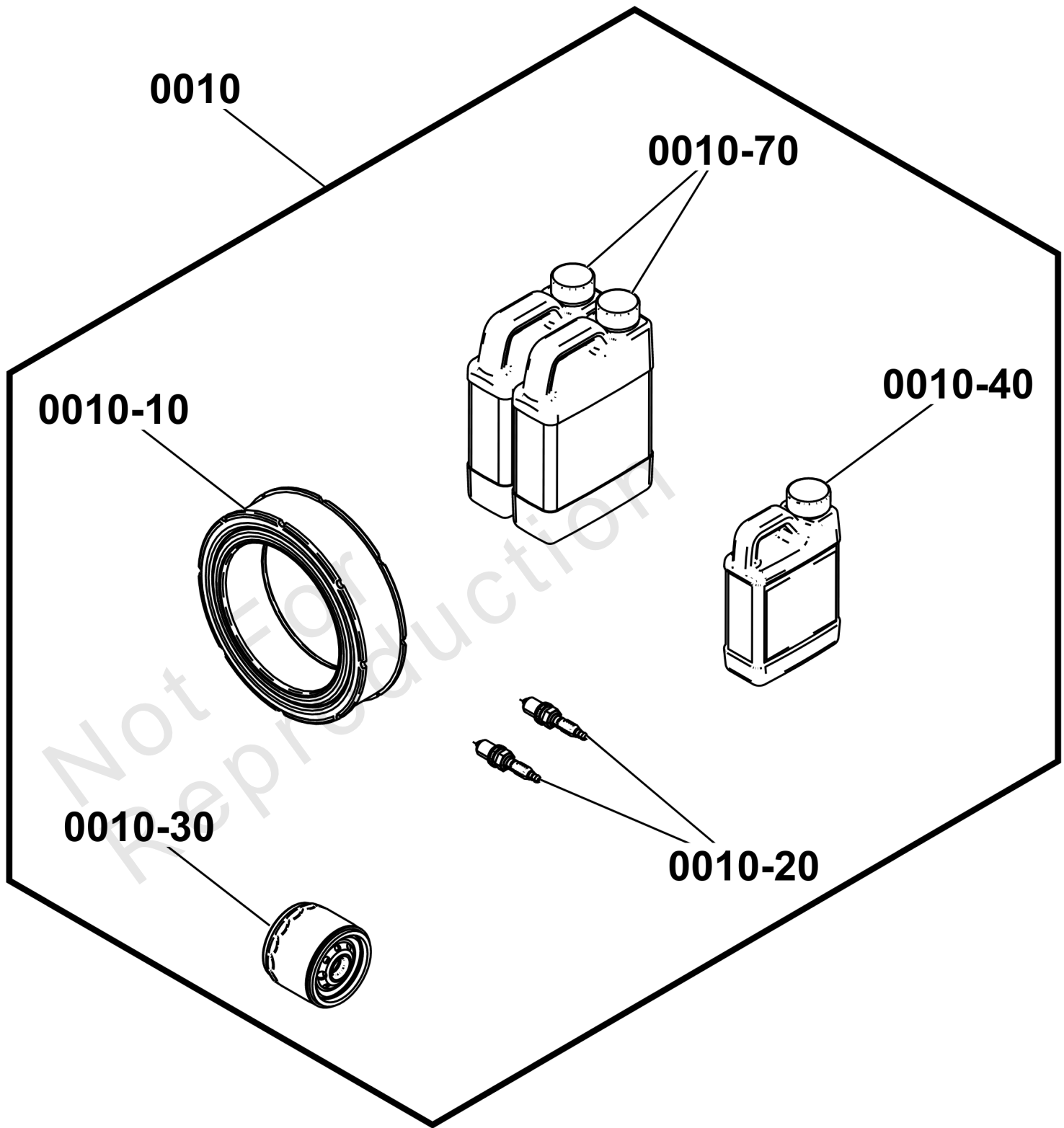

## Maintenance

REF NO	PART NO	QTY	DESCRIPTION
0010	6872	1	ACC, KIT, MAINTENANCE, 17-26000 -(Incl. Ref. Nos. 0010-10, 0010-20, 0010-30, 0010-40, 0010-70)
0010-10	-----	1	CARTRIDGE, Air Cleaner
0010-20	72347GS	2	PLUG, Spark
0010-30	841023	1	FILTER, OIL
0010-40	-----	1	BOTTLE, 16oz Oil
0010-70	-----	2	BOTTLE, 32oz Oil

Not For Reproduction



Not For  
Reproduction

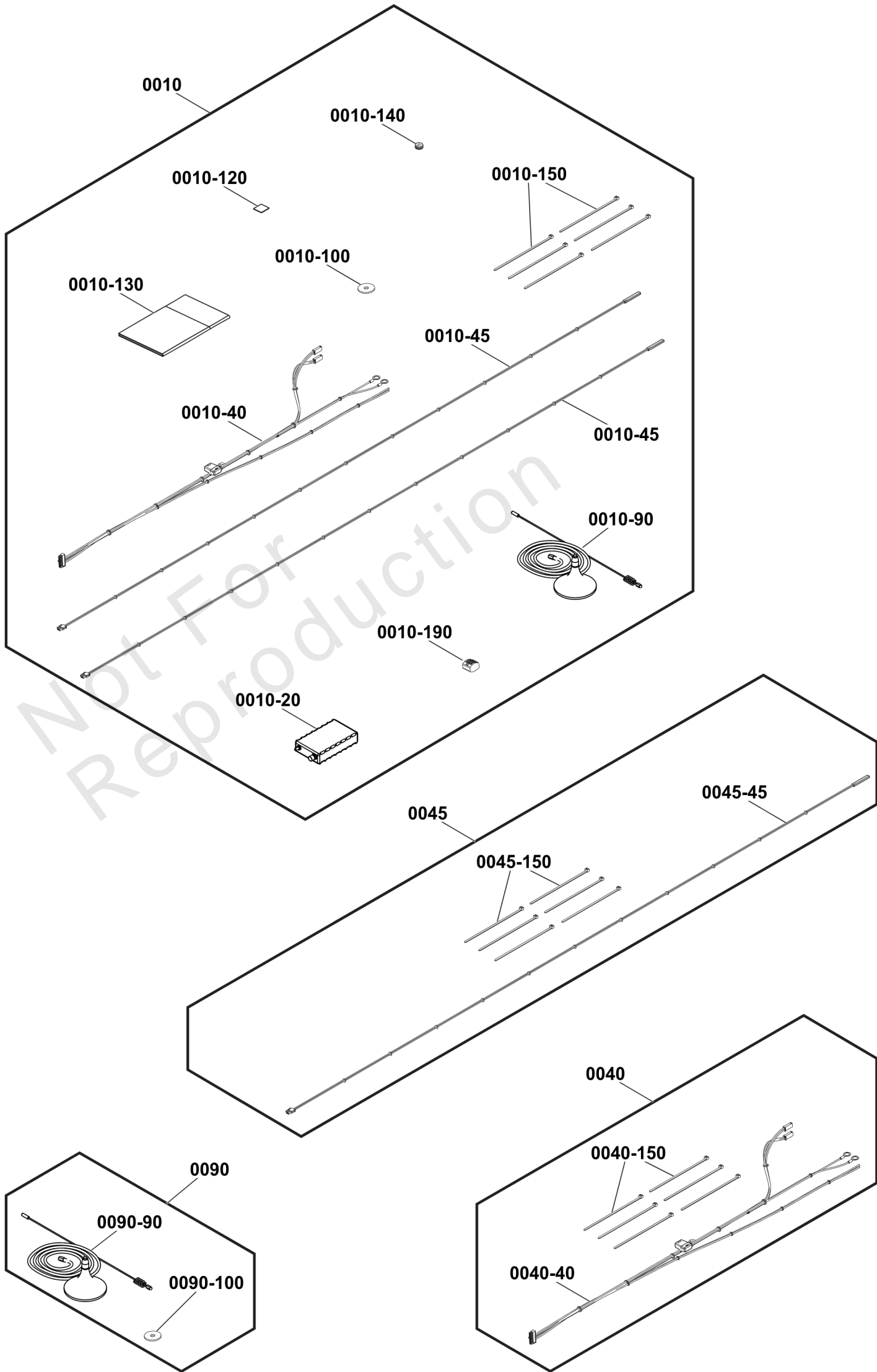

## Infohub

REF NO	PART NO	QTY	DESCRIPTION
0010	6574	1	KIT, Infohub SP, Agnostic -(Incl. Ref. Nos. 0010-20, 0010-40, 0010-45, 0010-90, 0010-100, 0010-120, 0010-130, 0010-140, 0010-150, 0010-190)
0010-20	-----	1	INFOHUB, UNIV
0010-40	-----	1	HARNESS, Infohub SP, Agnostic
0010-45	-----	2	ASSEMBLY, Voltage Sensor
0010-90	-----	1	ANTENNA, Cell Quad Band
0010-100	703591	1	WASHER, .406X1.5X.12
0010-120	-----	1	STRIP, Adhesive Mounting
0010-130	-----	1	MANUAL, Operator
0010-140	316855GS	1	GROMMET
0010-150	29333AGS	6	TIEWRAP, 7 LG BLK
0010-190	197956GS	1	BLOCK, Terminal w/Levers
0040	84003260	1	HARNESS, Infohub SP, Agnostic -(Incl. Ref. Nos. 0040-40, 0040-150)
0040-40	-----	1	HARNESS, Infohub SP, Agnostic
0040-150	29333AGS	6	TIEWRAP, 7 LG BLK
0045	84003258	1	ASSEMBLY, Voltage Sensor -(Incl. Ref. Nos. 0045-45, 0045-150)
0045-45	-----	1	ASSEMBLY, Voltage Sensor
0045-150	29333AGS	6	TIEWRAP, 7 LG BLK
0090	84003261	1	ANTENNA, Cell Quad Band -(Incl. Ref. Nos. 0090-90, 0090-100)
0090-90	-----	1	ANTENNA, Cell Quad Band
0090-100	703591	1	WASHER, .406X1.5X.12



# 6581-00 - Uninterruptible Power Supply - (UPS)

Not For  
Reproduction

**Uninterruptible Power Supply - (UPS)**

Note: Unless noted otherwise, use the standard torque specifications

Mfg. No: 6581-00



## ***Uninterruptible Power Supply - (UPS)***

REF NO	PART NO	QTY	DESCRIPTION
0010	6581	1	KIT, ACC, UPS 350VA/255W, 120VAC -(Incl. Ref. No. 0010-10)
0010-10	-----	1	UPS 350VA/255W, 120VAC

Not For Reproduction

# 6491-01 - Estop Switch



Not For  
Reproduction

# Estop Switch

Note: Unless noted otherwise, use the standard torque specifications

Mfg. No: 6491-01

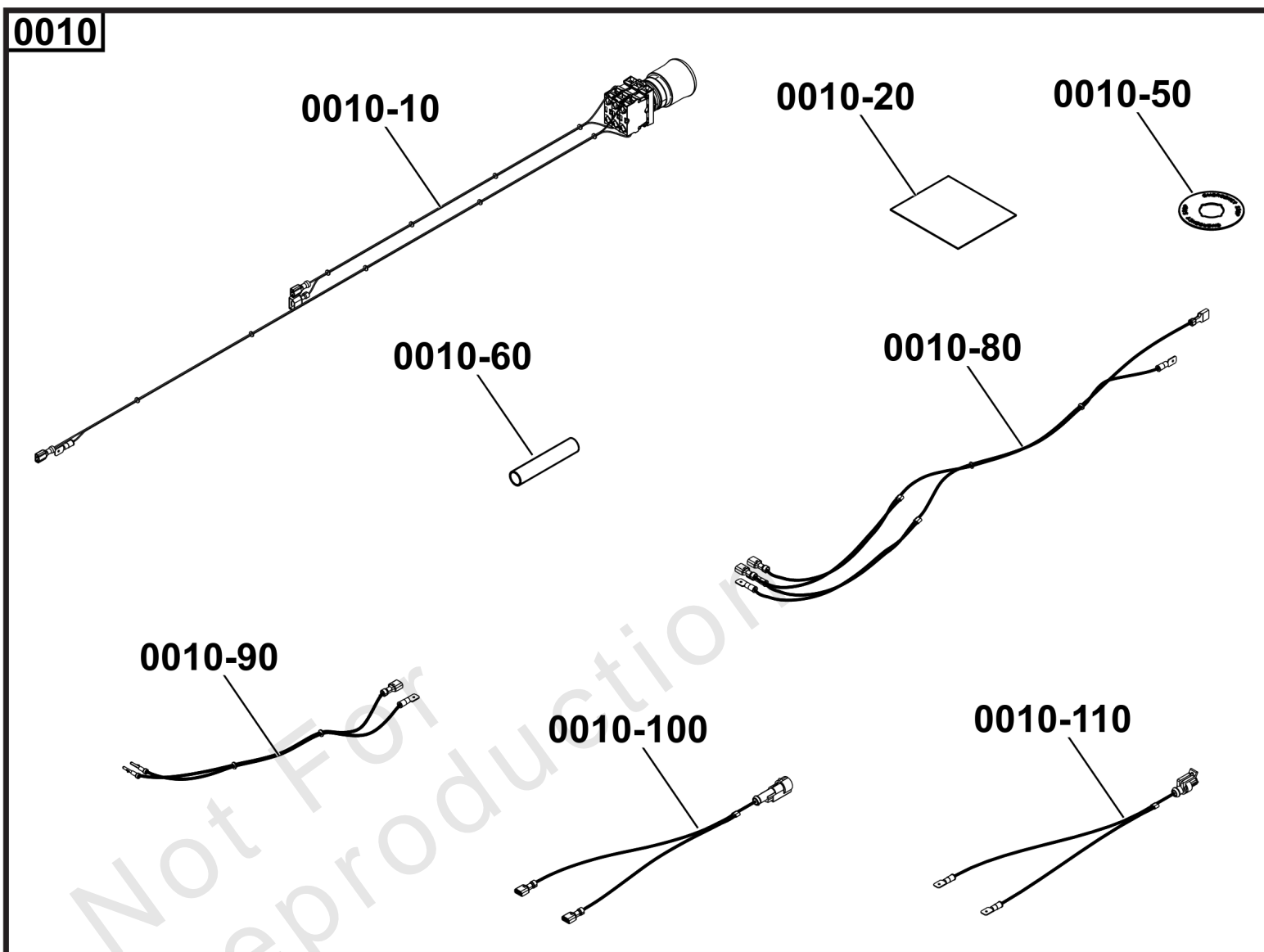

## ***Estop Switch***

<b>REF NO</b>	<b>PART NO</b>	<b>QTY</b>	<b>DESCRIPTION</b>
0010	6491	1	ACC KIT, SWITCH, E-STOP -(Incl. Ref. Nos. 0010-10, 0010-20, 0010-50, 0010-60, 0010-80, 0010-90, 0010-100, 0010-110)
0010-10	-----	1	ASSEMBLY, Switch, E-Stop
0010-20	-----	1	DECAL
0010-50	-----	1	LEGEND PLATE, E-Stop
0010-60	-----	1	TUBING, Heat Shrink
0010-80	-----	1	HARNESS
0010-90	-----	1	HARNESS
0010-100	-----	1	HARNESS
0010-110	-----	1	HARNESS

Not For Reproduction



Not For  
Reproduction

## USB Cable

Note: Unless noted otherwise, use the standard torque specifications

Mfg. No: 6428-00

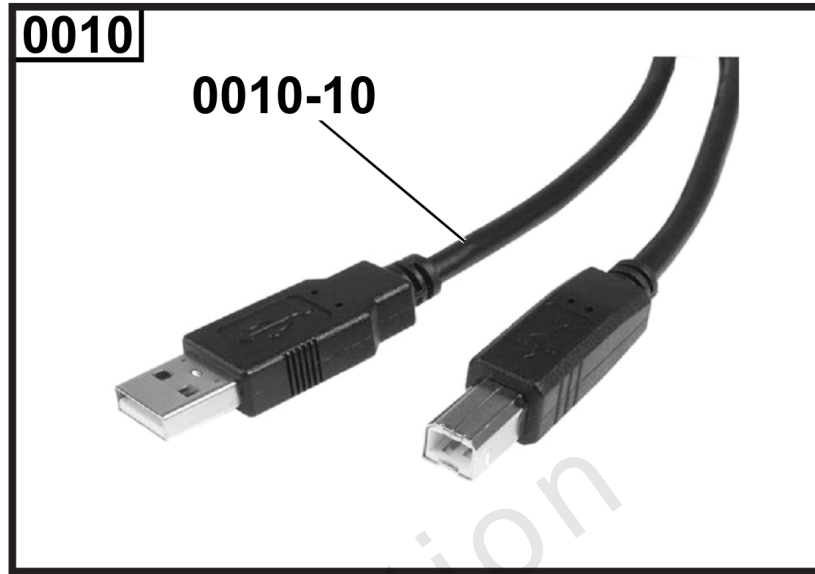

## USB Cable

REF NO	PART NO	QTY	DESCRIPTION
0010	6428	1	KIT, Communication Cable -(Incl. Ref. No. 0010-10)
0010-10	-----	1	CABLE, USB

Not For Reproduction



# 6631-00 - Surge Protective Device (SPD)

Not For  
Reproduction

**Surge Protective Device (SPD)**

Note: Unless noted otherwise, use the standard torque specifications

Mfg. No: 6631-00

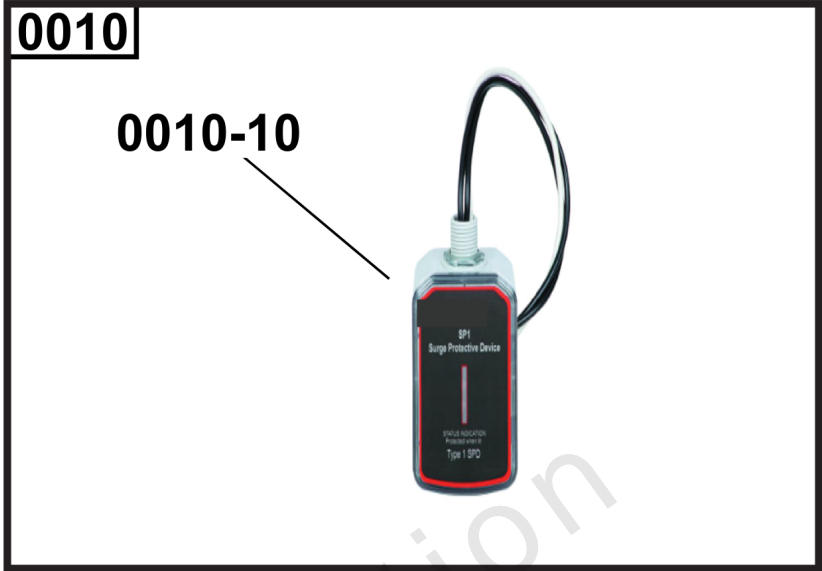

Not For  
Reproduction

## Surge Protective Device (SPD)

REF NO	PART NO	QTY	DESCRIPTION
0010	6631	1	SURGE PROTECTIVE DEVICE (SPD) -(Incl. Ref. No. 0010-10)
0010-10	-----	1	SURGE PROTECTIVE DEVICE (SPD)

Not For Reproduction

# Hardware Identification & Torque Specifications

Torque Specification Chart								
FOR STANDARD METRIC MACHINE HARDWARE (Tolerance ± 20%)								
Property Class	5.6		8.8		10.9		12.9	
	Class 5.6		Class 8.8		Class 10.9		Class 12.9	
Size Of Hardware	in/lbs	Nm.	in/lbs	Nm.	in/lbs	Nm.	in/lbs	Nm.
	ft/lbs		ft/lbs		ft/lbs		ft/lbs	
M3	5.88	.56	13.44	1.28	19.2	1.80	22.92	2.15
M4	13.44	1.28	30.72	2.90	43.44	4.10	52.56	4.95
M5	26.4	2.50	60.96	5.75	5.97	8.10	7.15	9.7
M6	44.64	4.3	7.3	9.9	10.3	14	12.1	16.5
M7	5.2	7.1	12.1	16.5	16.9	23	19.9	27
M8	7.7	10.5	17.7	24	25	34	29	40
M10	15	21	35	48	50	67	59	81
M12	26	36	61	83	86.2	117	103	140
M14	42	58	101	132	136	185	162	220
M16	64	88	147	200	210	285	250	340
M18	89	121	202	275	287	390	346	470
M20	126	171	290	390	405	550	486	660
M22	169	230	390	530	559	745	656	890
M24	217	295	497	375	708	960	840	1140
M27	320	435	733	995	1032	1400	1239	1680
M30	435	590	995	1350	1401	1900	1681	2280
M33	590	800	1349	1830	1902	2580	2278	3090
M36	759	1030	1740	2360	2441	3310	2935	3980
M39	988	1340	2249	3050	3163	4290	3798	5150

Torque Specification Chart						
FOR STANDARD MACHINE HARDWARE (Tolerance ± 20%)						
Hardware Grade	No Marks		SAE Grade 5		SAE Grade 8	
	SAE Grade 2		SAE Grade 5		SAE Grade 8	
Size Of Hardware	in/lbs	Nm.	in/lbs	Nm.	in/lbs	Nm.
	ft/lbs		ft/lbs		ft/lbs	
8-32	19	2.1	30	3.4	41	4.6
8-36	20	2.3	31	3.5	43	4.9
10-24	27	3.1	43	4.9	60	6.8
10-32	31	3.5	49	5.5	68	7.7
1/4-20	66	7.6	8	10.9	12	16.3
1/4-28	76	8.6	10	13.6	14	19.0
5/16-18	11	15.0	17	23.1	25	34.0
5/16-24	12	16.3	19	25.8	29	34.0
3/8-16	20	27.2	30	40.8	45	61.2
3/8-24	23	31.3	35	47.6	50	68.0
7/16-14	30	40.8	50	68.0	70	95.2
7/16-20	35	47.6	55	74.8	80	108.8
1/2-13	50	68.0	75	102.0	110	149.6
1/2-20	55	74.8	90	122.4	120	163.2
9/16-12	65	88.4	110	149.6	150	204.0
9/16-18	75	102.0	120	163.2	170	231.2
5/8-11	90	122.4	150	204.0	220	299.2
5/8-18	100	136	180	244.8	240	326.4
3/4-10	160	217.6	260	353.6	386	525.0
3/4-16	180	244.8	300	408.0	420	571.2
7/8-9	140	190.4	400	544.0	600	816.0
7/8-14	155	210.8	440	598.4	660	897.6
1-8	220	299.2	580	788.8	900	1,244.0
1-12	240	326.4	640	870.4	1,000	1,360.0

The guides and ruler furnished below are designed to help you select the appropriate hardware.



Nut, M8

Thread Diameter (mm)

Inside Diameter (in)      Threads per inch

Nut, 1/2-16

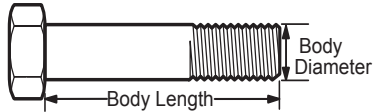

Screw, M8- 1.25 x 25

Thread Diameter (mm)      Distance between threads (mm)      Body Length (mm)

Body Diameter      Threads per inch      Body Length (in)

Screw, 1/2- 16 x 2

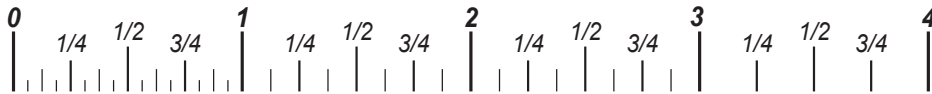

## Standard Hardware Sizing

When a washer or nut is identified as 1/2" (M8), this is the *Nominal size*, meaning the *inside diameter* is 1/2 inch (8mm metric thread diameter); if a second number is present it represents the *threads per inch* (distance between threads).

When bolt or capscrew is identified as 1/2 - 16 x 2" (M8 - 1.25 x 50), this means the *Nominal size*, or body diameter is 1/2 inch (8mm metric thread diameter), the second number, 16, represents the *threads per inch*, (*distance between threads*). The final number is the body length of the bolt or screw, 2 inches (50mm).

## NOTES

- These torque values are to be used for all hardware excluding: locknuts, self-tapping screws, thread forming screws, sheet metal screws and socket head setscrews.
- Recommended seating torque values for locknuts:
  - for prevailing torque locknuts - use 65% of grade 5 torques.
  - for flange whizlock nuts and screws - use 135% of grade 5 torques.
- Unless otherwise noted on assembly drawings, all torque values must meet this specification.

## Common Hardware Types

Hex Head Capscrew

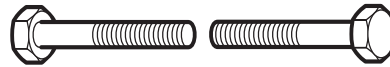

Washer

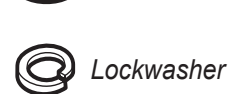

Carriage Bolt



Hex Nut

## Wrench & Fastener Size Guide

1/4" Bolt or Nut Wrench—7/16"	5/16" Bolt or Nut Wrench—1/2"	3/8" Bolt or Nut Wrench—9/16"	7/16" Bolt or Nut Wrench (Bolt)—5/8" Wrench (Nut)—11/16"	1/2" Bolt or Nut Wrench—3/4"
M6 Bolt or Nut Wrench—10mm	M8 Bolt or Nut Wrench—13mm	M10 Bolt or Nut Wrench—17mm	M12 Bolt or Nut Wrench—19mm	M14 Bolt or Nut Wrench—22mm

