

FAB28ULBL3



Product family	Refrigerator
Installation	Free-standing
Category	Single door
Defrost	Automatic for refrigerator, manual for freezer
Hinge position	Left
EAN code	8017709271725



Aesthetic

Aesthetics	Retro-style	Logo	Applied
Color	Black	Door shelf profile color	Chromed
Finishing	Glossy	Drawers profile color	Chromed
Side material	Steel	Glass shelf profile color	Chromed
Side color	Black		

Refrigerator compartment features



No. of adjustable shelves	3	Bottle shelf	Yes
Number of fruit and vegetables drawers	1	Type of crisper cover	Glass
Type of adjustable shelves	Glass	LifePlus zone - 32°F	28° to 37°F
Crisper drawer type	Sliding crisper	Refrigerator lighting	Yes
Crisper cover	Yes	Refrigerator lighting	LED

Refrigerator Inner Door

No. of door shelves with transparent cover	2	No. of bottle shelves	1
Number of adjustable door shelves	2	Door bin with wire support	Yes
Adjustable door bins with wire support	Yes		

Freezer features

Internal freezer compartment Yes

Other technical features



Door open alarm	Acoustic and visual
Antibacterial gasket	Yes
Temperature setting type	Electronic
No. of compressors	1
Refrigerant gas type	R600a
Compressor type	Inverter
Foam agent	Cyclopentane

Performance / Energy Label NEW



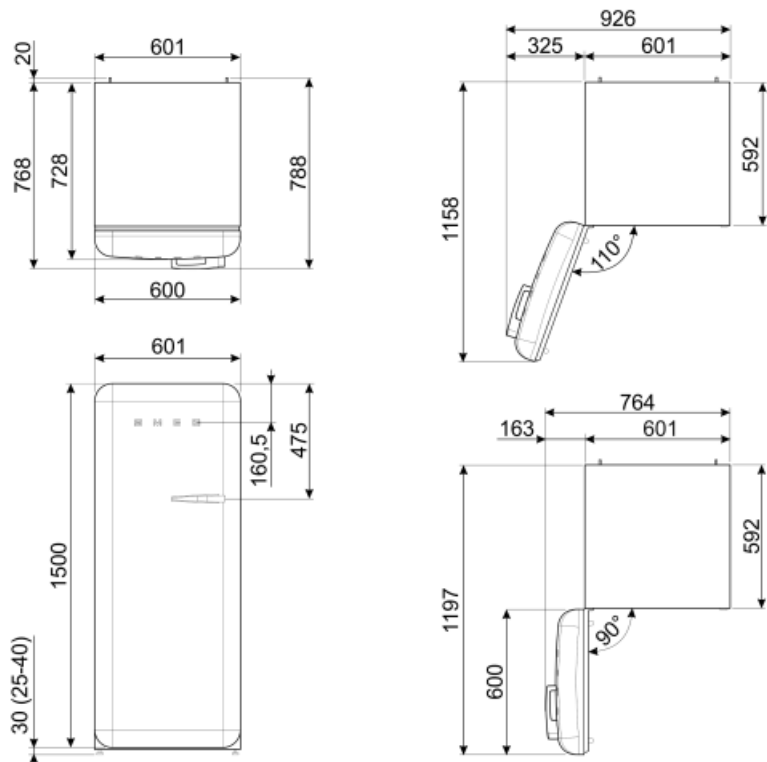

Annual energy consumption	230 KWh/year	Refrigerator compartment	0.00 cu. ft.
Total volume	0.00 cu. ft.	Total volume	0.00 cu. ft.
Freezer volume	0.00 cu. ft.		

Electrical Connection

Plug	(A) USA & Mexico	Frequency (Hz)	50/60 Hz
Current	2,2 A	Power cord length	70 7/8 "
Voltage (V)	120 V		



Symbols glossary (TT)

- | | | | |
|--|--|---|--|
|  | <p>The automatic defrost system works by automatically defrosting at regular intervals eliminating the need to defrost altogether.</p> |  | <p>Antibacterial treatment: antibacterial treatment to ensure better hygiene</p> |
|  | <p>LED interior lighting: is a more energy efficient and long lasting way of illuminating the interior of the appliance.</p> |  | <p>Life Plus 0°C: The temperature in the Lifeplus compartments is kept at 0°C, which preserves fresh meat and fish longer.</p> |
|  | <p>Inverter technology: The evolution of Smeg's driers towards more intelligent and environmentally sustainable models has led to the choice of using Inverter technology with heat pumps, which reduces significantly energy consumption.</p> | | |