

# Oven, 30", 9 Function, Self-cleaning

Series 7 | Contemporary

Stainless Steel



This built-in oven has a large capacity and multiple functions, to ensure every dish is cooked to perfection.

- 4.1 cu ft total capacity
- Nine oven functions including Aero™ Broil and Aero™ Pastry
- High-temperature self-cleaning function breaks down food residue for an easy clean
- Non-tip, full-extension shelves for safe removal of hot dishes

## DIMENSIONS

Height	27 1/16"
Width	29 29/32"
Depth	23 29/32"

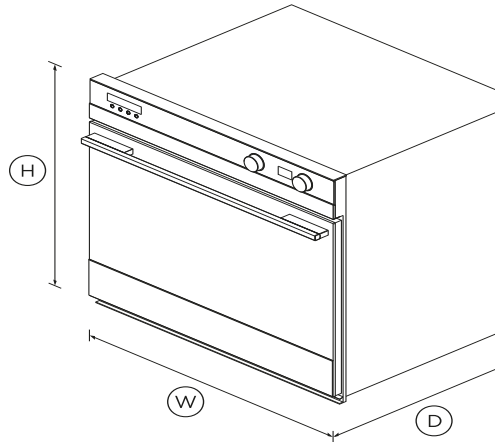

## FEATURES & BENEFITS

### EVEN COOKING

Our built-in ovens feature AeroTech™ - a technology that circulates heat evenly, ideal for multi-shelf cooking.

### SELF CLEANING

The self-clean function breaks down food residue at a very high temperature, leaving a light ash that's easily removed with a damp cloth. For best results, wipe down the inside of your oven door before you use the self-clean function.

### SIZED TO SUIT

Designed for multi-shelf cooking, this is one of the largest built-in ovens on the market providing 4.1 cu.ft of total capacity. The

higher internal cavity allows you to fit a large casserole dish, the family roast and a pie for dessert.

### SAFE AND SOUND

The CoolTouch door with triple glazing and cooling system is safe to touch from the outside, protecting your hands and the surrounding cabinetry. Getting large dishes in and out of the oven is a breeze with full telescopic sliding shelves that stay perfectly steady - even when pulled all the way out.

### COMPLEMENTARY DESIGN

With their premium handle styling and stainless steel finish, our built-in ovens are designed to match the rest of Fisher & Paykel's kitchen appliance family.

### COOKING FLEXIBILITY

This built-in oven has nine functions with pre-set temperatures, including Bake, Classic Bake and Aero™ Broil allowing you to use a variety of cooking styles.

## SPECIFICATIONS

### Accessories

2pc broil system (pan + rack)	•
Full extension telescopic	2 Sets (Additional sets)
Meat probe	1

### Accessories (sold separately)

Handle kit Contemporary	Part number 81672
-------------------------	-------------------

### Capacity

Shelf positions	8
Total capacity	4cu ft

### Cleaning

- Acid resistant graphite enamel
- Pyrolytic self-clean
- Removable oven door
- Removable shelf runners

**Controls**

- Audio feedback
- Automatic cooking/minute
- Automatic pre-set
- Celsius/Fahrenheit
- Door and cavity cooling
- Electronic capacitive touch
- Electronic clock
- Internal light
- Intuitive touchscreen display
- Precise electronic temperature
- Sabbath mode

**Functions**

- Aero Bake
- Aero Broil
- Aero Pastry
- Bake
- Classic bake
- Dehydrate
- Maxi Broil
- Number of functions **9**
- Self-clean
- True Aero
- Warm

**Performance**

- AeroTech™ technology
- Automatic rapid pre-heat
- Broil power **4400W**

**Power requirements**

- Amperage **19.5A**
- Supply frequency **60Hz**
- Supply voltage **120 - 240V**

**Product dimensions**

- Depth **23 29/32"**
- Height **27 1/16"**
- Width **29 29/32"**

**Safety**

- Advanced cooling system
- Balanced oven door
- Catalytic venting system
- Child lock
- Control panel key lock
- CoolTouch door
- Full extension telescopic
- Non-tip shelves

**Warranty**

- Parts and labor **2 years**

SKU

81512

The product dimensions and specifications in this page apply to the specific product and model. Under our policy of continuous improvement, these dimensions and specifications may change at any time. You should therefore check with Fisher & Paykel's Customer Care Centre to ensure this page correctly describes the model currently available. ? Fisher & Paykel Appliances Ltd 2020

---

Other product downloads available at [fisherpaykel.com](http://fisherpaykel.com)



[Quick Start Guide](#)



[Service & Warranty](#)



[User Guide](#)



[Installation Guide / Guide d'installation](#)



[Data Sheet Oven](#)



**A PEACE OF MIND SALE**

**24 Hours 7 Days a Week Customer Support**

**T 1.888.936.7872 W [www.fisherpaykel.com](http://www.fisherpaykel.com)**