

CAS1200/4 AMPLIFIER

The CAS1200/4 is a fully DSP-enabled outdoor amplification system delivering a total of 1200W between four channels. This system is designed to be used in exterior wall mount applications for outdoor speaker systems. It comes ready with dual 5P Line Level Inputs. The four programmable channels offer unrivaled control and flexibility.

NOTES:

1. This amplifier ships with the channels preconfigured for the CS speakers ordered with the system.
2. CAS should always be installed in a shady area if possible, and the lid should be fully screwed down to ensure waterproofing.



WHITE

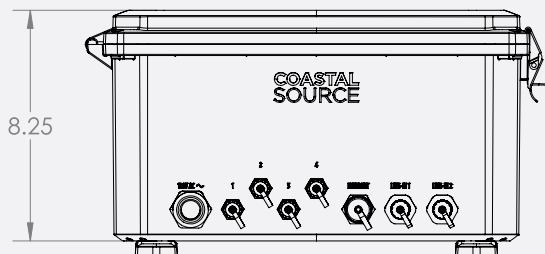
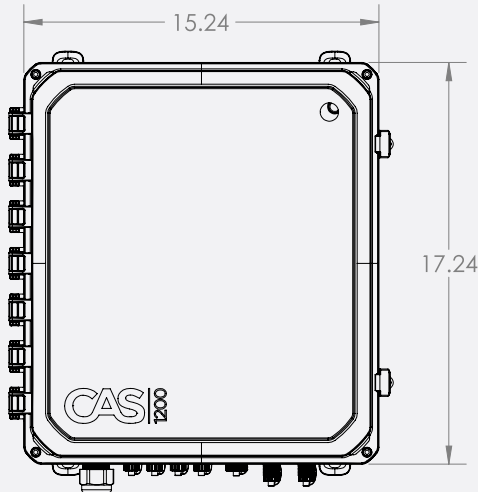

CAS1200/4 AMPLIFIER SPECIFICATIONS

- Dimensions: 17.24" x 15.24" x 8.25" (438x387x210mm)
- Weight: 26 lbs (11.8 kg)
- Construction: Polycarbonate & Stainless Steel
- Max Speakers: Up to 2 speakers per channel & up to 4 subs total.
- Frequency Response at 8 ohms: 20Hz-20kHz +/- 0.5 dB
- Idle Power: 28W
- Power In: 100-240 VAC @ 50-60Hz
- Power Out: 1200W
- Impedance: Stable to 4 ohms
- Mounting: Wall (brackets included)
- Input Connections: 2x 5P Line Level Connection
- Output Connections: 4x Coastal Connectors (CC)
- Warranty: 5-Year Limited Warranty*

OUTDOOR LIGHTING AND AUDIO
[ENGINEERED] **FOR LIFE**

ORDERING INFORMATION

FIXTURE

CAS1200/4 (CAS1200/4 AMPLIFIER)

CAS1200/4

e.g. **CAS1200/4** = CAS1200/4 Amplifier

ACCESSORIES

SKU

ITEM

CxxLL5P

5-Pin Line Level
Extension Cables

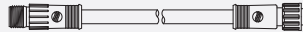

FMCRCAS5P

5-Pin Line Level
Cable Adapters (5P)

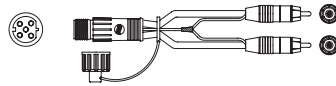

*All Coastal Source products bear a 2-year limited warranty for commercial/non-residential installations.

**COASTAL
SOURCE**
[defy the elements]

Please visit coastalsource.com for more information or call us at 1-800-719-1996. You will always be pleased you purchased a Coastal Source product.

p. 800.719.1996
info@coastalsource.com
coastalsource.com

CORPORATE OFFICE
1270 GLEN AVENUE
MOORESTOWN, NJ 08057