



### Mini Cooper Hardtop coupe 3-dr (F56) 2014-2017 †

### Mini Cooper Hardtop sedan 5-dr (F55) 2014-2017 †

Visit [MetraOnline.com](http://MetraOnline.com) for more detailed information about the product and up-to-date vehicle specific applications

#### KIT FEATURES

- ISO DIN radio provision with pocket
- ISO DDIN radio provision
- Retains the factory hazard button
- Painted high gloss black with a matte black trim to match the factory appearance

† Base model radio without a high-def display

#### KIT COMPONENTS

- A) Radio bezel • B) Bezel mount • C) Radio brackets • D) Pocket • E) Phillips screws (4) • F) Panel clips (4)

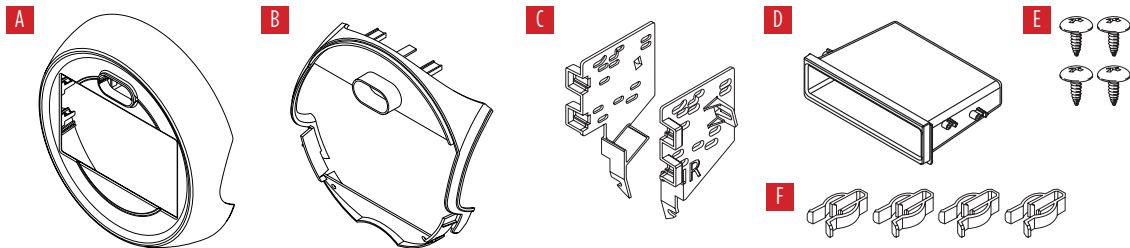

#### TABLE OF CONTENTS

Dash Disassembly .....	2
Kit Preparation .....	3
Kit Assembly	
–ISO DIN radio provision with pocket .....	4
–ISO DDIN radio provision.....	5

#### WIRING & ANTENNA CONNECTIONS (sold separately)

Wiring Harness: • See metraonline for harness interface solutions

Antenna Adapter: 40-EU55 (sold separately)

#### TOOLS REQUIRED

- Panel removal tool • Phillips screwdriver
- Heavy duty pick tool (or flat-blade screwdriver)
- T-20 Torx screwdriver

**Attention!** Let the vehicle sit with the key out of the ignition for a few minutes before removing the factory radio. When testing the aftermarket equipment, ensure that all factory equipment is connected before cycling the key to ignition.

## DASH DISASSEMBLY

1. Remove (2) expanding rivets securing the bottom of the radio bezel, then unclip and remove the bezel. (Figure A)
2. Remove (2) Torx T-20 screws securing the bottom of the radio. (Figure B)
3. Unclip and remove the speaker grille on top of the dash. (Figure C)

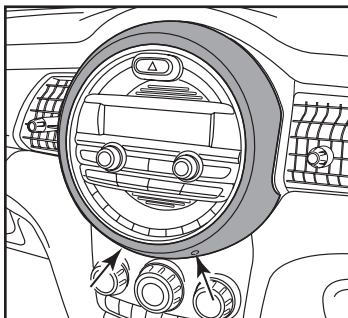

(Figure A)

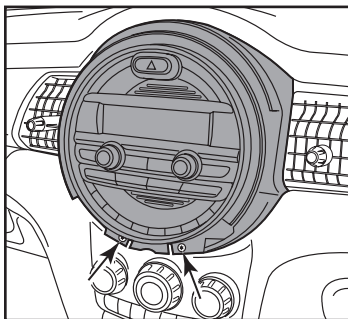

(Figure B)

4. Locate the access hole under the speaker grille. Using a heavy duty pick tool or flat-blade screwdriver, push down on the locking clip holding the top of the radio. It may be best to have a helper assist by pulling the top of the radio outward. (Figure D)
5. Slide the radio out, then unplug and remove.

*Continue to Kit Preparation*

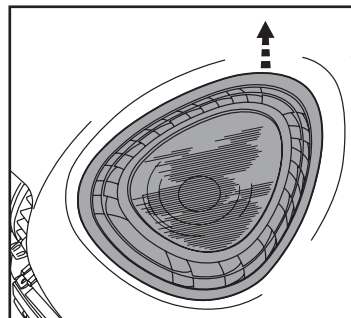

(Figure C)

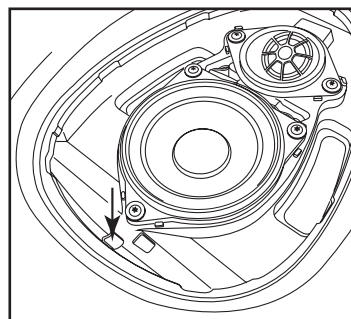

(Figure D)

## KIT PREPARATION

### From the factory radio panel:

1. Remove (2) metal retainer clips. Attach the clips onto the bezel mount. (Figure A)
2. Unclip and remove the hazard switch (Figure A)

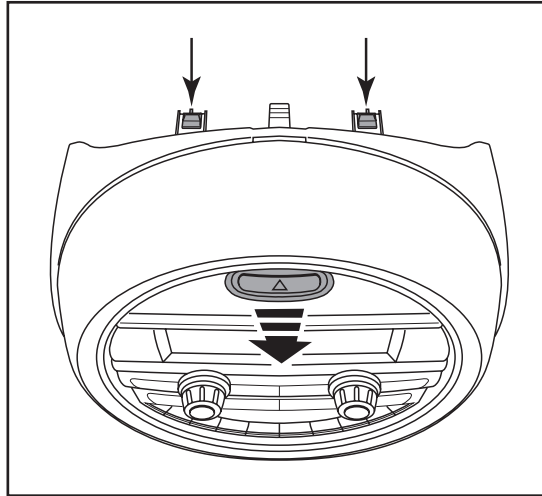

(Figure A)

### To the radio bezel provided with the kit:

3. Attach (4) panel clips provided. (Figure B)

*Continue to Kit Assembly*

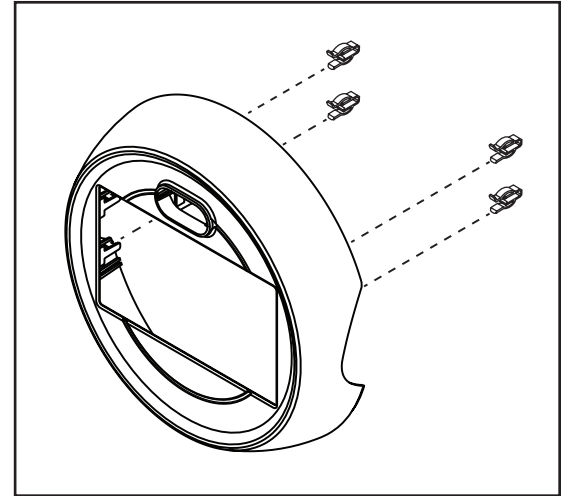

(Figure B)

## KIT ASSEMBLY

### ISO DIN radio provision with pocket

1. Remove (2) T-20 Torx screws securing the a/c vents. (Figure A)
2. Route the hazard switch wiring harness through the **bezel mount**, then clip the mount to the dash. (Figure B)

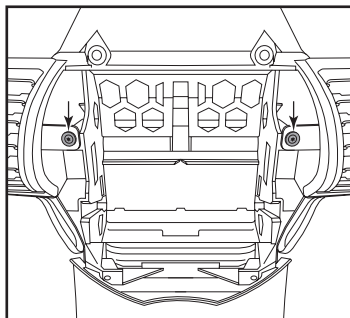

(Figure A)

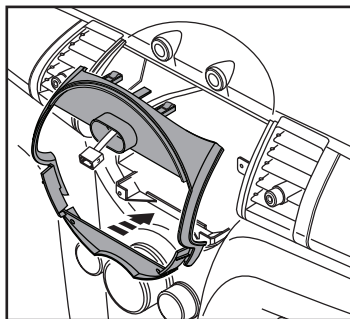

(Figure B)

3. Secure the **pocket** to the **radio brackets** using (4) Phillips screws provided. (Figure C)
4. Remove the metal DIN sleeve and trim ring from the aftermarket radio.
5. Slide the radio into the bracket/pocket assembly, then secure using screws supplied with the radio. (Figure D)

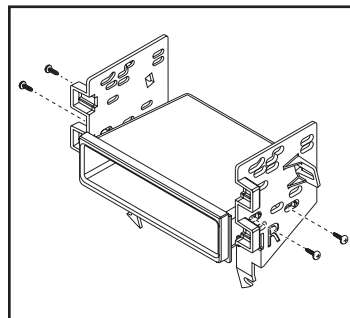

(Figure C)

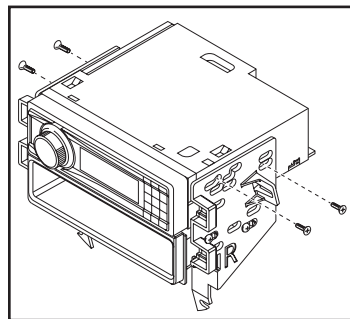

(Figure D)

## KIT ASSEMBLY (CONT.)

6. Locate the factory wiring harness and antenna connector in the dash and complete all necessary connections to the radio. Metra recommends using the proper mating adapter from Metra and/or Axxess. Test the radio for proper operation.
7. Slide the radio into the dash, then secure using (2) a/c vent screws up top, and (2) Torx T-20 screws removed in Dash Disassembly down below. (Figure E)
8. Route the hazard switch wiring harness through the **radio bezel**, then clip the bezel to the dash. Make sure to line up the two channels (keyways) on the inner sides of the bezel. (Figure F)
9. Connect the hazard switch, then clip it in to complete the installation. (Figure G)

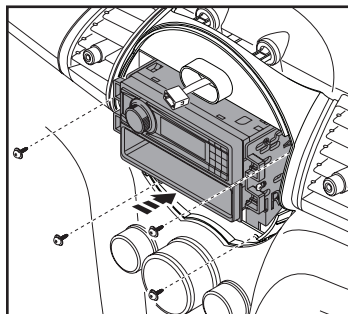

(Figure E)

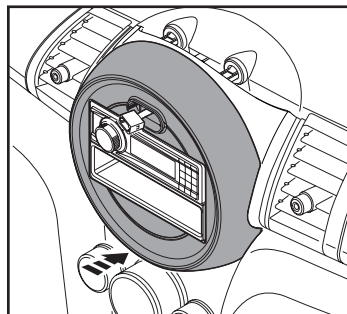

(Figure F)

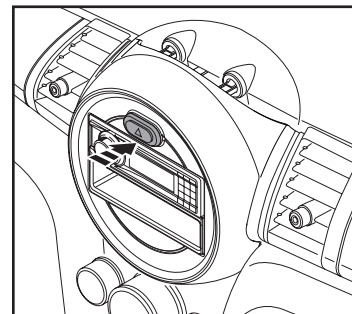

(Figure G)

## KIT ASSEMBLY

### ISO DDIN radio provision

1. Remove (2) T-20 Torx screws securing the a/c vents. (Figure A)
2. Route the hazard switch wiring harness through the **bezel mount**, then clip the mount to the dash. (Figure B)
3. Secure the **radio brackets** to the radio using screws supplied with the radio. (Figure C)
4. Locate the factory wiring harness and antenna connector in the dash and complete all necessary connections to the radio. Metra recommends using the proper mating adapter from Metra and/or Axxess. Test the radio for proper operation.

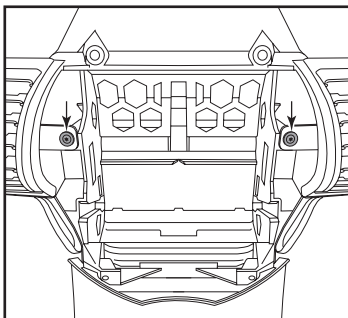

(Figure A)

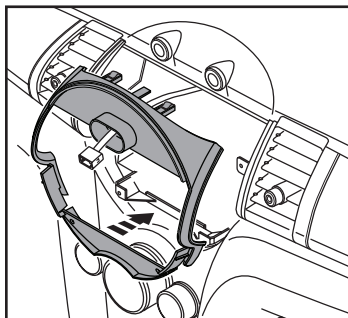

(Figure B)

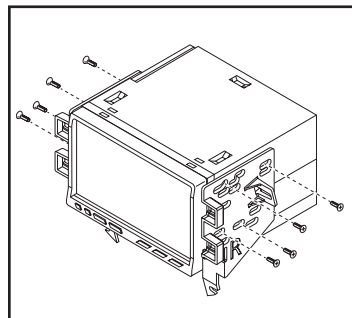

(Figure C)

## KIT ASSEMBLY (CONT.)

5. Slide the radio into the dash, then secure using (2) a/c vent screws up top, and (2) Torx T-20 screws removed in Dash Disassembly down below. (Figure D)
6. Route the hazard switch wiring harness through the radio bezel, then clip the bezel to the dash. Make sure to line up the two channels (keyways) on the inner sides of the bezel. (Figure E)
7. Connect the hazard switch, then clip it in to complete the installation. (Figure F)

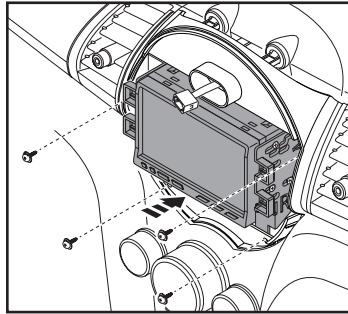

(Figure D)

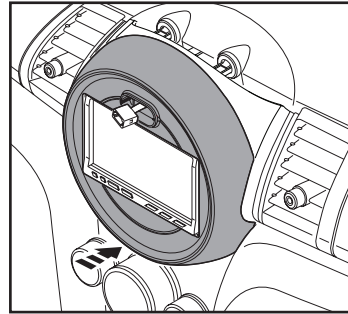

(Figure E)

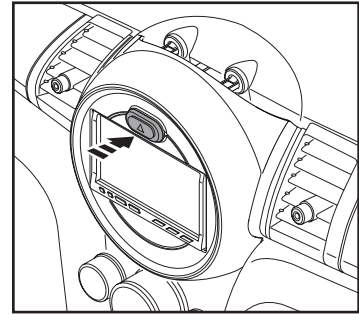

(Figure F)



**99-9326B**  
INSTALLATION INSTRUCTIONS



If you are having difficulties with the installation of this product, contact our Tech Support line either by phone at **386-257-1187**, or email at **techsupport@metra-autosound.com**. Before doing so, look over the instruction booklet a second time and ensure that the installation was performed exactly as the instruction booklet is stated. Have the vehicle apart and ready to perform troubleshooting steps before contacting Metra/Axxess Tech Support.



**KNOWLEDGE IS POWER**

Enhance your installation and fabrication skills by enrolling in the most recognized and respected mobile electronics school in our industry. Log onto [www.installerinstitute.com](http://www.installerinstitute.com) or call 800-354-6782 for more information and take steps toward a better tomorrow.



**Metra recommends MECP certified technicians**