

# euø style™

## Assembly Instructions

### BABA Flat High Back Office Chair

PLEASE NOTE: Check that you have received all components and hardware before assembling. If you are missing any parts, contact your retailer.



**IMPORTANT NOTE #1:** →  
Screws and washers (Parts I) are preassembled into the underside of the seat (Part B). Remove screws and washers from seat and then use to attach Part D to Part B, as shown in step 1.

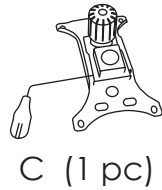
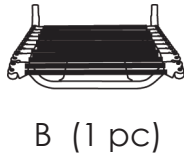
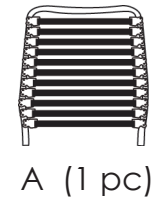
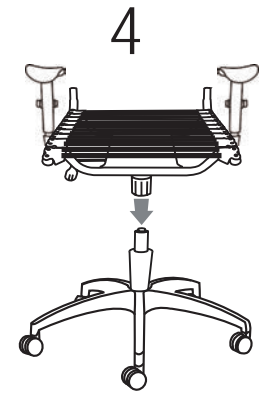
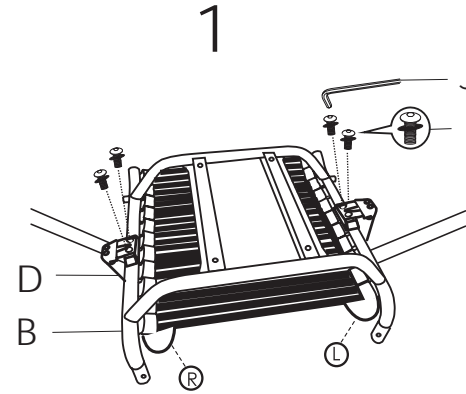

**IMPORTANT NOTE #2:** →  
Screws and washers (Parts G) are preassembled into the underside of the seat (Part B). Remove screws and washers from seat and then use to attach Part C to Part B, as shown in step 2.

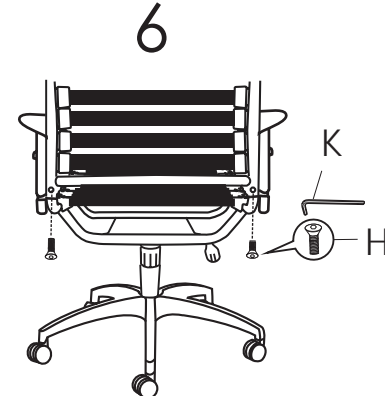
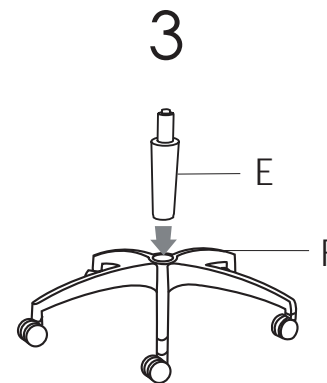
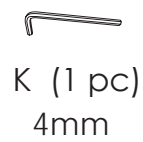
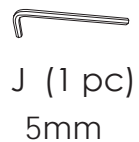
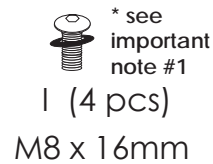
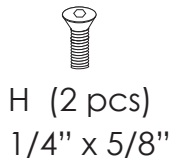
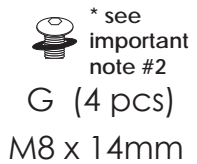
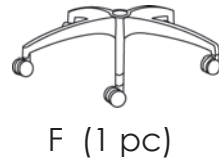
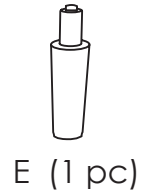
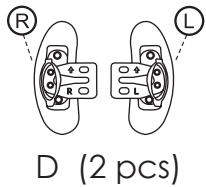
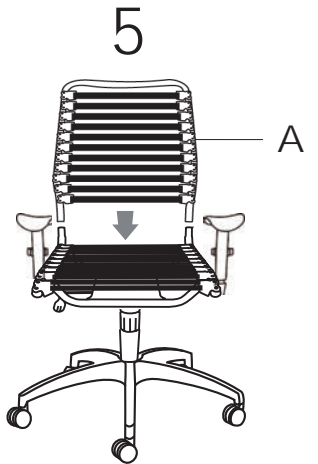
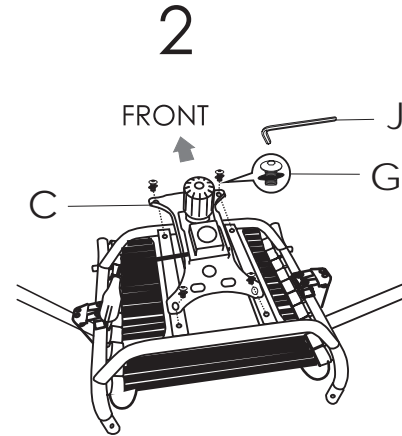

During assembly, hand tighten screws only. When the screws are in place, tighten completely.