

euø style™

Assembly Instructions

BUNGIE Flat Mid Back Office Chair

PLEASE NOTE: Check that you have received all components and hardware before assembling. If you are missing any parts, contact your retailer.

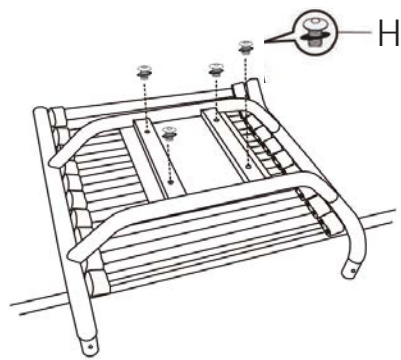

IMPORTANT NOTE:
Screws and washers (Parts H) are preassembled into the underside of the seat (Part B). Remove screws and washers from seat and then use to attach Part C to Part B, as shown in step 1.

