

AP T-Harness

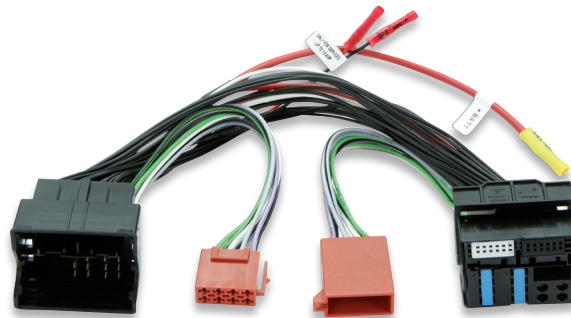

- 1 Designed specifically for your vehicle, for maximum OEM integration*.
- 2 Connection to the AP Extension cable through ISO connectors.
- 3 Possibility to supply power to the amplifier via the direct cockpit current system, without the need of routing the cable through the engine compartment (with Audison Prima DCC solution).
- 4 ACC wire to re-launch ignition key signal to turn on / off an external device**.

*The connector does not ensure the optical wires connection, where available, to the OEM source. It is required to disconnect the optical wires from the OEM connector and to connect them to the AP T-Harness.

**In those vehicles featuring ignition key connection wire (ACC wire), see compatibility list.

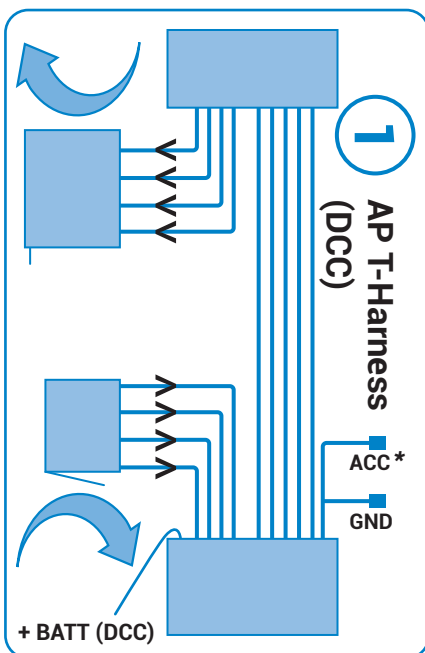

ITEM	DESCRIPTION
AP T-H BMW01	PRIMA T-HARNESS BMW*
AP T-H AVS01	PRIMA T-HARNESS AUDI, VW 40PIN*
AP T-H AVS02	PRIMA T-HARNESS AUDI, VW 52PIN
AP T-H TOL01	PRIMA T-HARNESS TOYOTA, LEXUS
AP T-H HON01	PRIMA T-HARNESS HONDA
AP T-H ISO01	PRIMA T-HARNESS ISO
AP T-H MBP01	PRIMA T-HARNESS MB, PORSCHE*
AP T-H INI01	PRIMA T-HARNESS NISSAN/INFINITI
AP T-H CHR01	PRIMA T-HARNESS CHRYSLER 2007 ->
AP T-H FCA01	PRIMA T-HARNESS FIAT/CHRYSLER
AP T-H GMN01	PRIMA T-HARNESS GM 2009 ->
AP T-H FRD01	PRIMA T-HARNESS FORD 2002 ->
AP T-H GMO01	PRIMA T-HARNESS GM 2006 ->