



Stainless Frame



Integrated Frame



Integrated Solid

### Additional Options

- Accessory panels are designed for easy installation on Integrated models
- Stainless lock model available



Stainless Handleless Panel



Stainless Lock Model

### Key Features

- **Industry Exclusive: Full-depth lower interior maximizes storage options**
- **Industry Leading: Variable speed compressor delivers maximum energy efficiency, faster temperature response, and quieter operation**
- Stainless steel interior
- Stainless steel cabinet, toe kick, and accents
- U-Adjust™ Interior: 19 adjustable positions
- Seven removable, full-extension wine racks
- Wine racks accommodate a variety of bottle shapes and sizes and can be configured to store champagne and magnum bottles
- Convection cooling system provides a quick cool down and consistent temperature
- Temperature range: 33°F - 70°F
- Adjustable bright white or blue LED lighting
- Soft close door with articulating hinge
- Volume of 2.9 cu ft holds up to 28 wine bottles (750 ml)
- Digital touch pad control with blue LED display
- Stainless steel handle (7/8" diameter)
- Integrated model requires 3/4" custom door panel and handle (not supplied by U-Line)
- Field reversible door is shipped right-hand hinged
- Built-in or freestanding
- Four adjustable leveling legs

### MODEL DETAILS

Model	Voltage/Hz	Door Swing	Finish	Shipping Weight
UHC515-SG01A	115 / 60	Field Reversible	Stainless Frame	105 lb
UHC515-SG41A	115 / 60	Right-Hand Hinged	Stainless Frame (with lock)	105 lb
UHC515-SG51A	115 / 60	Left-Hand Hinged	Stainless Frame (with lock)	105 lb
UHC515-IG01A	115 / 60	Field Reversible	Integrated Frame	103 lb
UHC515-IS01A	115 / 60	Field Reversible	Integrated Solid	88 lb

### ACCESSORIES

Model	Description	Finish	Shipping Weight
ULAGRILLE15	Adjustable Grille (Accepts Integrated Panel)	Black	1.5 lb
ULASHP15FRAME*	Stainless Handleless Panel Frame	Stainless	5 lb
ULASHP15SOLID*	Stainless Handleless Panel Solid	Stainless	6 lb

\*Installs on integrated models.

# HWC515 • 15" Wine Refrigerator • 5 Class

**Front**

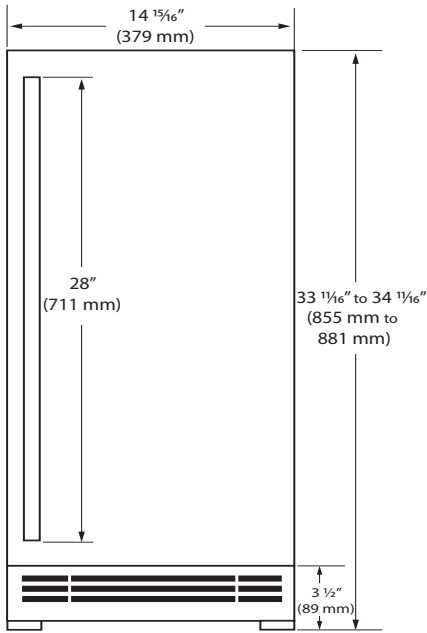

**Side**

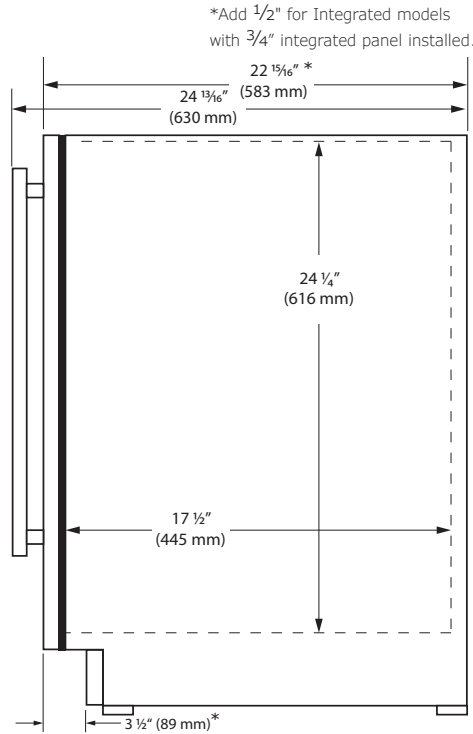

**Top**

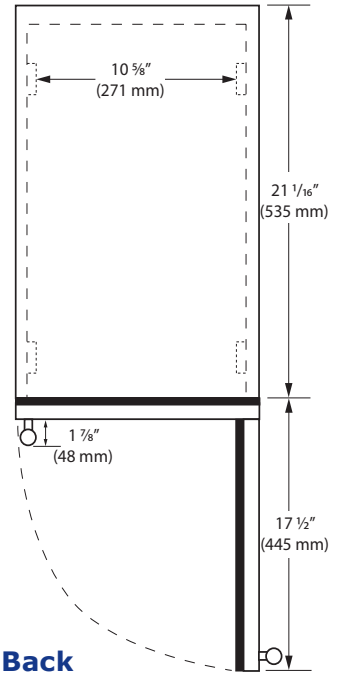

**Back**

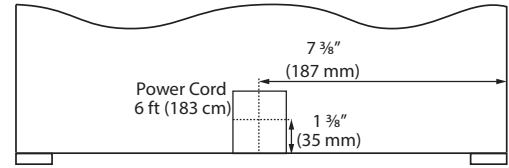

## Specifications

Model	HWC515
Amps: Running	1.2
Capacity: Bottle (12 oz)	N/A
Capacity: Can (12 oz)	N/A
Capacity: Volume (cu ft)	2.9
Capacity: Wine Bottle (750 ml)	28
Dimensions: Product Depth	22 15/16" / 583 mm
Dimensions: Product Height (Min.)	33 1/16" / 855 mm
Dimensions: Product Width	14 15/16" / 379 mm
Energy Consumption: Avg. Per Year	255 - 285 kWh
ENERGY STAR (glass door)	No
ENERGY STAR (solid door)	Yes
Panel Height	30" / 762 mm
Panel Thickness	3/4" / 20 mm
Panel Type	2 3/4" / 70 mm Frame Panel or Solid Panel
Panel Width	14 15/16" / 379 mm
Product Weight: Max	105 lb
Refrigerant Type:	R600a
Sabbath (Star K Certified)	Yes
Temperature Range	33°F - 70°F

## Cabinet Cut-Out

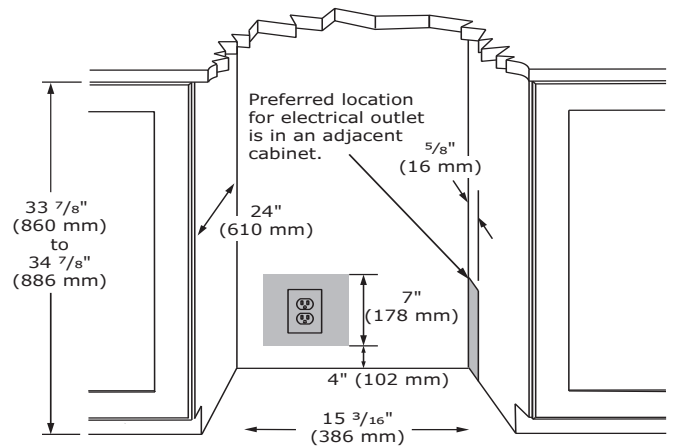

## Installation Notes

- 15" Cutout width may be sufficient if opening is exact and square
- No additional clearance is needed for ventilation
- Do not obstruct front grille air flow

## Warranty

- 2 Year (parts & labor) / 5 year sealed system (parts)

+ **Additional 1 Year (parts & labor) warranty at no cost with product registration**



See complete warranty for details

Please visit [u-line.com](http://u-line.com) to view this model's User Guide & Service Manual. All Specifications are subject to change without notice.

