

WARRANTY REGISTRATION
**REGISTER FOR
EXTRA BENEFITS**

Activate within 30 days of purchase:
seura.com/activate



SÉURA

Shade Series 2™

WELCOME GUIDE

SHD2-43
SHD2-55
SHD2-65
SHD2-75

Specifications

43 INCH **55 INCH** **65 INCH** **75 INCH**
 Model: SHD2-43 Model: SHD2-55 Model: SHD2-65 Model: SHD2-75

GENERAL	OPERATING TEMP. RANGE	-24°F to 104°F*			
	IDEAL OPERATING TEMP.	32°F to 104°F			
	NON-OPERATING TEMP.	-24°F to 140°F			
	OPERATING HUMIDITY	10%-90% Relative Humidity, Non-Condensing			
	WATERPROOF RATING	IP56 Rating†			
VIDEO	DISPLAY RESOLUTION	3840 x 2160			
	DISPLAY BRIGHTNESS	700 Nits			
	ASPECT RATIO	16:9			
	CONTRAST RATIO	Typical 5000:1			
	DOLBY DIGITAL SUPPORT	Dolby Digital 5.1			
	HDR COMPATIBLE	HDR			
	RESPONSE TIME	8 ms			
	VIEWING ANGLE	178° Horizontal/Vertical			
DISPLAY POWER CONS.	138 watts / 1.26a @ 120v	210 watts / 1.91a @ 120v	280 watts / 2.55a @ 120v	360 watts / 3.28a @ 120v	
INSTALLATION	DIMENSIONS	37.7" w x 21.6" h x 2.9" d	48.3" w x 27.6" h x 2.9" d	57.1" w x 32.4" h x 2.9" d	65.8" w x 37.3" h x 2.9" d
	TV WEIGHT	25 lbs.	38 lbs.	56 lbs.	78 lbs.
	TV + SOUNDBAR WEIGHT	35 lbs.	52 lbs.	74 lbs.	100 lbs.
	MEDIA COMPARTMENT DIMENSIONS	3.75" w x 4" h x 1.125" d	3.75" w x 4" h x 1.125" d	3.75" w x 4" h x 1.125" d	3.75" w x 4" h x 1.125" d
	VESA PATTERN	300 x 300mm	400 x 200mm	400 x 200mm	400 x 200mm

* The screen is most optimally viewed at ambient temperatures of 32°F to 104°F

† IP Rating is an international standard that specifies the degree of protection against dust and water ingress. Séura Outdoor Displays are IP rated and designed to protect against rain, snow, ice, dust, and other outdoor elements.

Manufactured under license from Dolby Laboratories. Dolby and the double-D symbol are trademarks of Dolby Laboratories.

WARNING: READ ALL INSTRUCTIONS BEFORE ATTEMPTING TO INSTALL OR SERVICE THIS PRODUCT.



This symbol is intended to alert the user to the presence of uninsulated "dangerous voltage" within the product's enclosure that may be of sufficient magnitude to constitute a risk of electric shock to persons.



This symbol is intended to alert the user to the presence of important operating and maintenance instructions in the literature accompanying the appliance.

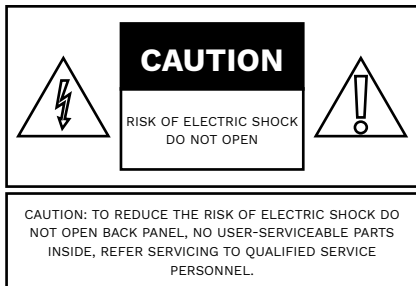

Warnings:

Do not handle or remove your outdoor display from the packaging until it is ready to be installed.

To avoid damage to the outdoor display, only transport it in a vertical position.

It is highly recommended that at least two (2) persons assist in the installation of the outdoor display.

Do not submerge Séura® Outdoor Display in water:

The Séura® Outdoor Display will resist water exposure from normal rain, sprinklers, snow, etc.; however, it is not designed to be submerged in water.

Do not wash with garden hose or pressure-wash:

Séura® Outdoor Display will resist water exposure from normal rain, sprinklers, snow etc.; however, it is not designed to withstand pressure washers, high-pressure water jets, projected snow from a blower, or hurricane-type weather.

Do not let metal pieces or objects of any kind fall into the display. High voltage flows in the product, and inserting an object can cause electric shock and/or short internal parts.

To prevent fire, never place any type of candle or flames on the top or near the display.

To prevent fire or shock hazard, do not place the AC cord under the display or other heavy items.

Power Lines

An outside antenna system should not be located in the vicinity of overhead power lines or other electric light or power circuits, or where it can fall into such power lines or circuits. When installing an outside antenna system, extreme care should be taken to keep from touching such power lines or circuits as contact with them might be fatal.

Accessories

Do not use accessories not specifically recommended by the manufacturer. Use of improper attachments can result in accidents.

AVERTISSEMENT: LIRE TOUTES LES INSTRUCTIONS AVANT D'INSTALLER OU SERVICE CE PRODUIT.



Ce symbole est destiné à alerter l'utilisateur de la présence d'une «tension dangereuse» non isolée à l'intérieur de l'enceinte du produit qui peut être d'une amplitude suffisante pour constituer un risque de choc électrique pour les personnes.



Ce symbole est destiné à alerter l'utilisateur de la présence d'instructions importantes d'utilisation et de maintenance dans la documentation accompagnant l'appareil.



Avertissements:

Ne pas manipuler ou supprimer votre moniteur extérieure de l'emballage jusqu'à ce qu'il soit prêt à être installé. Pour éviter d'endommager la moniteur en plein air, seul le transporter dans une position verticale. Il est fortement recommandé qu'au moins deux (2) personnes aident à l'installation de la moniteur en plein air.

N'immergez pas le Séura® Outdoor moniteur dans l'eau: le moniteur Séura® Outdoor résistera à l'exposition à l'eau causée par la pluie, les gicleurs, la neige, etc. Cependant, il n'est pas conçu pour être immergé dans l'eau.

Ne lavez pas avec un tuyau d'arrosage ou avec un nettoyeur haute pression: Séura® Outdoor moniteur résistera à l'exposition à l'eau causée par la pluie, les sprinklers, la neige, etc. Cependant, il n'est pas conçu pour résister aux laveuses à pression, aux jets d'eau à haute pression, aux projections de neige d'un ventilateur ou aux intempéries de type ouragan.

Ne laissez pas de morceaux de métal ou d'objets de toute sorte tomber dans la moniteur. Une tension élevée circule dans le produit et l'insertion d'un objet peut provoquer un choc électrique et / ou un court-circuit des pièces internes.

Pour éviter les incendies, ne placez jamais de bougies ni

de flammes sur le dessus ou à proximité du moniteur.

Pour éviter tout risque d'incendie ou d'électrocution, ne placez pas le cordon d'alimentation sous le moniteur ou d'autres objets lourds.

Les lignes électriques

Une antenne extérieure ne doit pas être située à proximité de lignes électriques aériennes ou d'autres circuits d'éclairage ou de circuits électriques, ni à un endroit où elle pourrait tomber dans de telles lignes ou circuits. Lorsque vous installez une antenne extérieure, veillez à ne pas toucher ces lignes ou circuits électriques, car tout contact avec ces derniers pourrait être fatal.

Accessoires

N'utilisez pas d'accessoires non spécifiquement recommandés par le fabricant. L'utilisation d'accessoires inappropriés peut entraîner des accidents.



WARNINGS

Never place a television set in an unstable location. A television set may fall, causing serious personal injury or death. Many injuries, particularly to children, can be avoided by taking simple precautions such as:

- Using cabinets or stands recommended by the manufacturer of the television set.
- Only using furniture that can safely support the television set.
- Ensuring the television set is not overhanging the edge of the supporting furniture.
- Not placing the television set on tall furniture (for example, cupboards or bookcases) without anchoring both the furniture and the television set to a suitable support.
- Not placing the television set on cloth or other materials that may be located between the television set and supporting furniture.
- Educating children about the dangers of climbing on furniture to reach the television set or its controls.

If your existing television set is being retained and relocated, the same considerations as above should be applied.



WARNING: Cancer and Reproductive Harm: www.p65warnings.ca.gov.

Specifications of this product are subject to unannounced changes; this manual may thus not reflect the current technical status.

Spécifications de ce produit sont sujettes à modifications sans préavis; ce manuel ne peut donc pas tenir compte de l'état de la technique actuelle.



ATTENTION

Ne placez jamais un téléviseur dans un endroit instable. Un téléviseur peut tomber

et causer des blessures graves ou mortelles. Beaucoup de blessures, en particulier aux enfants, peuvent être évitées en prenant des précautions simples telles que:

- *Utilisation des armoires ou des supports recommandés par le fabricant du téléviseur.*
- *Seulement en utilisant des meubles qui peuvent supporter en toute sécurité le téléviseur.*
- *Assurer le téléviseur est pas surplombant le bord du meuble de support.*
- *Non placer le téléviseur sur un grand meuble (par exemple, des armoires ou des bibliothèques) sans accrocher à la fois les meubles et le téléviseur sur un support approprié.*
- *Non placer le téléviseur sur le tissu ou d'autres matériaux qui peuvent être situés entre le téléviseur et le mobilier de soutien.*
- *Éduquer les enfants sur les dangers de grimper sur un meuble pour atteindre le téléviseur ou ses commandes.*

Si votre téléviseur existant est conservé et transféré, les mêmes considérations que ci-dessus doivent être appliquées.

FCC Supplier's Declaration of Conformity

Séura Outdoor Entertainment
SHD2-43, SHD2-55, SHD2-65, SHD2-75

This device complies with part 15 of the FCC Rules. Operation is subject to the following two conditions: (1) This device may not cause harmful interference, and (2) this device must accept any interference received, including interference that may cause undesired operation.

PAN International
Address: 48008 Fremont Blvd, Fremont, CA 94538 United States
Phone number: 510-623-3810



Caution: The user is cautioned that changes or modifications not expressly approved by the party responsible for compliance could void the user's authority to operate the equipment.

Note: This equipment has been tested and found to comply with the limits for a Class B digital device, pursuant to part 15 of the FCC Rules. These limits are designed to provide reasonable protection against harmful interference in a residential installation. This equipment generates uses and can radiate radio frequency energy and, if not installed and used in accordance with the instructions, may cause harmful interference to radio communications. However, there is no guarantee that interference will not occur in a particular installation. If this equipment does cause harmful interference to radio or television reception, which can be determined by turning the equipment off and on, the user is encouraged to try to correct the interference by one or more of the following measures:

- Reorient or relocate the receiving antenna.
- Increase the separation between the equipment and receiver.
- Connect the equipment into an outlet on a circuit different from that to which the receiver is connected
- Consult the dealer or an experienced radio/TV technician for help.

This equipment complies with FCC radiation exposure limits set forth for an uncontrolled environment. This equipment should be installed and operated with a minimum distance of 20 cm between the radiator and any part of your body.



WARNINGS

To reduce the risk of fire, electrical shock and other injuries, keep these safety precautions in mind when installing, using, and maintaining your outdoor display. The socket-outlet should be installed near the equipment and be easily accessible. The display should be connected to a grounded GFCI protected main socket outlet.

WARNING: If you manipulate against the recommended usage, serious injury or death to user may result.



AVERTISSEMENTS

Pour réduire le risque d'incendie, de choc électrique et d'autres blessures, garder ces consignes de sécurité à l'esprit lors de l'installation, l'utilisation et l'entretien de votre moniteur en plein air. La prise de courant doit être installée près de l'équipement et être facilement accessible. Le moniteur doit être relié à une prise de courant avec terre protégé par disjoncteur différentiel.

ATTENTION: Si vous manipulez contre l'utilisation recommandée, des blessures graves ou la mort à l'utilisateur peuvent en résulter.

Important Safety Instructions

1. Read these instructions.
2. Keep these instructions.
3. Heed all warnings.
4. Follow all instructions.
5. Clean only with a dry cloth.
6. Do not block any of the ventilation openings. Install in accordance with the manufacturer's instructions.
7. Do not install near any heat sources such as radiators, heat registers, stoves, or other apparatus (including amplifiers) that produce heat.
8. Do not defeat the safety purpose of the polarized or grounding type plug. A polarized plug has two blades with one wider than the other. A grounding type plug has two blades and a third grounding prong. The wide blade or the third prong is provided for your safety. When the provided plug does not fit into your outlet, consult an electrician for replacement of the obsolete outlet.
9. Protect the power cord from being walked on or pinched particularly at plugs, convenience receptacles, and the point where they exit from the apparatus.
10. Only use the attachments/accessories specified by the manufacturer.
11. Use only with the cart, stand, tripod, bracket, or table specified by the manufacturer, or sold with the apparatus. When a cart is used, use caution when moving the cart/apparatus combination to avoid injury from tip-over.
12. Unplug this apparatus during lightning storms or when unused for long periods of time.
13. Refer all servicing to qualified service personnel. Servicing is required when the apparatus has been damaged in any way, such as power supply cord or plug is damaged, liquid has been spilled or objects have fallen into the apparatus, the apparatus has been exposed to rain or moisture, does not operate normally, or has been dropped.
14. To reduce the risk of fire or electric shock, do not expose the inside of this apparatus to rain or moisture. The inside of this apparatus shall not be exposed to dripping or splashing.
15. The apparatus shall not be exposed to dripping or splashing and that no objects filled with liquids, such as vases, shall be placed on the apparatus.
16. The apparatus shall be connected to a MAINS socket outlet with a protective earthing connection. Where the MAINS plug or an appliance coupler is used as the disconnect device, the disconnect device shall remain readily operable.
17. The disconnect device shall remain readily operable.
18. The socket-outlet shall be installed near the equipment and shall be easily accessible.
19. Inspect the desired location for installation and be aware of all electrical wiring pathways, water pipes, gas lines, or other potentially hazardous conditions that may exist to protect from accidental damage during creation of on-site conditions.
20. Ensure all required electrical specifications are adhered to and have been installed by the appropriate individuals and are code approved.
21. Ensure all framing requirements, if needed, have been completed to building code and pose no structural issues.
22. It is REQUIRED that this product is plugged into an electrical outlet protected by a Ground Fault Circuit Interrupter (GFCI) to protect against electric shock, fire, and/or injury. Failure to do so will void any warranty for this product.
23. Only qualified individuals should attempt to service the product. Removing covers can expose you to high voltage and other dangerous conditions.
24. Do not overload AC outlets or extension cords. Overloading can cause fire or electric shock.
25. Close adult supervision is necessary when any product is used by or near children.
26. Do not operate any product with a damaged cord or plug or operate it after the appliance malfunctions or has been damaged in any manner.
27. To electrically disconnect the product, turn OFF the product, then remove the electrical power plug from the outlet.
28. This Séura product is intended for use indoors and outdoors.
29. If you notice any smoke or scorched smell near the product, unplug power cord and refer to qualified personnel for service and/or repair.
30. Do not use or place any combustible or flammable substances near the product.
31. Do not use this product for other than intended use.
32. This product is water resistant. Do not immerse this product in water.



Consignes De Sécurité Importantes

1. Lisez ces instructions.
2. Conservez ces instructions.
3. Respectez tous les avertissements.
4. Suivez toutes les instructions.
5. Nettoyer uniquement avec un chiffon sec.
6. Ne pas bloquer les ouvertures de ventilation. Installez conformément aux instructions du fabricant.
7. Ne pas installer près de sources de chaleur telles que des radiateurs, registres de chaleur, poêles ou autres appareils (y compris les amplificateurs) qui produisent de la chaleur.
8. Ne pas contourner le dispositif de sécurité de la fiche polarisée ou mise à la terre. Une fiche polarisée possède deux lames dont une plus large que l'autre. Une prise de terre a deux lames et une troisième broche de mise à la terre. La lame large ou la troisième broche est fournie pour votre sécurité. Si la fiche fournie ne rentre pas dans votre prise, consultez un électricien pour remplacer la prise obsolète.
9. Protégez le cordon d'alimentation d'être piétiné ou pincé, en particulier au niveau des fiches, des prises de courant, et le point où ils sortent de l'appareil.
10. Utilisez uniquement les fixations / accessoires spécifiés par le fabricant.
11. Utilisez uniquement avec un chariot, un support, un trépied, un support ou une table spécifié par le fabricant ou vendu avec l'appareil. Quand un chariot est utilisé, faites attention lorsque vous déplacez l'ensemble chariot / appareil pour éviter les blessures en cas de chute.
12. Débranchez l'appareil en cas d'orage ou lorsqu'il est inutilisé pendant de longues périodes de temps.
13. Les travaux de personnel qualifié. Une réparation est nécessaire lorsque l'appareil a été endommagé de quelque façon que ce cordon d'alimentation ou la fiche est endommagé, du liquide a été renversé ou des objets sont tombés dans l'appareil, l'appareil a été exposé à la pluie ou à l'humidité, ne fonctionne pas normalement, ou est tombé.
14. Pour réduire le risque d'incendie ou de choc électrique, ne pas exposer l'intérieur de cet appareil à la pluie ou à l'humidité. L'intérieur de cet appareil ne doit pas être exposé à des gouttes ou des éclaboussures.
15. L'appareil ne doit pas être exposé à des gouttes ou des éclaboussures et aucun objet rempli de liquide, comme des vases, ne doit être placé sur l'appareil.
16. L'appareil ne doit être relié à une prise secteur dotée d'une connexion de terre de protection. Lorsque la prise du RESEAU D'ALIMENTATION ou une prise placée sur l'appareil est utilisée comme dispositif de déconnexion, ce dispositif doit demeurer aisément accessible.
17. Le dispositif de déconnexion doit rester facilement accessible.
18. La prise de courant doit être installée près de l'équipement et doit être facilement accessible.
19. Inspecter l'emplacement souhaité pour l'installation et être conscient de toutes les voies de câblage électrique, les canalisations d'eau, conduites de gaz, ou d'autres conditions potentiellement dangereuses qui peuvent exister pour protéger contre les dommages accidentels lors de la création des conditions sur place.
20. S'assurer que toutes les spécifications électriques requises sont respectées et ont été installés par les personnes appropriées et sont le code approuvé.
21. S'assurer que toutes les exigences d'encadrement, si nécessaire, ont été achevés au code du bâtiment et ne posent pas de problèmes structurels.
22. Il est nécessaire que ce produit est branché sur une prise électrique protégée par un disjoncteur de fuite à la terre (GFCI) pour protéger contre les chocs électriques, des incendies et / ou blessures. Ne pas le faire annulera toute garantie pour ce produit.
23. Seules les personnes qualifiées doivent tenter de réparer le produit. Le retrait des capots peut vous exposer à de hautes tensions et d'autres situations dangereuses.
24. Ne surcharge pas les prises de courant ou les rallonges. Une surcharge peut causer un incendie ou un choc électrique.
25. Fermer surveillance d'un adulte est nécessaire lorsque tout appareil est utilisé par ou près des enfants.
26. Ne pas utiliser un produit avec un cordon ou une fiche détériorés fonctionner après un mauvais fonctionnement de l'appareil ou a été endommagé d'une manière quelconque.
27. Pour débrancher électriquement le produit, éteignez le produit, puis retirez la fiche d'alimentation électrique de la prise.
28. Ce produit Séura est destiné à un usage intérieur et extérieur.
29. Si vous remarquez de la fumée ou une odeur de brûlure à proximité du produit, débranchez le cordon d'alimentation et consultez un personnel qualifié pour le service et / ou la réparation.
30. N'utilisez ni ne placez aucune substance combustible ou inflammable à proximité du produit.
31. N'utilisez pas ce produit pour un usage autre que celui prévu.
32. Ce produit est résistant à l'eau. Ne pas plonger ce produit dans l'eau.



The screen is most optimally viewed at ambient temperatures of 32°F to 104°F

Operation and Storage Requirements

The maximum ambient temperature range for operating the device is **-24°F to 104°F**. The screen is most optimally viewed at ambient temperatures of **32°F to 104°F**. Do not install the device in the proximity of heat sources, such as heating pipes, heaters, furnaces or other devices that radiate heat. Mount the device in such a way that it is protected against moisture. To prevent fire or electric shock, never allow liquids to enter the unit. The uninstalled product must be stored in dry and well-ventilated rooms, without extreme temperature fluctuations. Heat sources and aggressive active substances may not be stored in the proximity of the device. The required storage temperature is **-24°F to 140°F**. The device must be stored in the complete packaging, as delivered.

When the unit is used in temperatures below the ideal operating temperature range, the picture may appear slightly delayed or blurred. This is normal, and the picture will return to normal after the temperature increases to the ideal operating temperature range.



IMPORTANT

The display should not be installed directly over a flat surface if heavy or driving rain may puddle and splash up onto the lower portion of the display. Direct sunlight on the display screen will heat internal components and should be avoided.

IMPORTANT

Le moniteur ne doit pas être installé directement sur une surface plane, si de fortes pluies ou de conduite peut flaquer d'eau et éclabousser sur la partie inférieure du moniteur. Lumière directe du soleil sur l'écran du moniteur va chauffer les composants internes et devrait être évitée.

Get to know your Séura® Shade Series™ Outdoor Display

If you have questions, call Séura at 1-800-957-3872 to speak to a design expert.



Sunlight — Do not use this product in direct sunlight. This product is designed for shaded applications only. Exposure to direct sunlight has the potential to permanently damage electronics.

Selecting the Installation Location

Select a place with no direct sunlight and good ventilation. It is also recommended to orient the product to face either north or south. Screen exposure to the east or west may compromise picture performance in sunlight.

Installation over a gas fireplace is acceptable if the distance from the heat source is such that the air temperature surrounding the display does not exceed the maximum operating temperature. A mantle or other heat shield is recommended to further protect the display from heat. Installation over a wood fireplace or near heaters or blowers is not recommended and may result in damage to the electronics. If you have questions about your situation, you may call Séura at 1-800-957-3872 to speak to a design expert.

Not for installation in a sauna or directly above a hot tub where extreme heat and steam could damage the electronics.

Ventilation

Adequate ventilation must be maintained to ensure reliable and continued operation and to protect the display from overheating. There must be **at least 1.5 inches of space on all sides**. Do not install inside a cabinet, kiosk, or other enclosure.

Cable Management

When running cables from inside the compartment to the sources, allow adequate spacing at the foam entry to the cabinet that allows the foam seal to completely surround each cable. Bunching the cables together can create gaps in the foam that allows moisture and insects to enter the cabinet that may result in damage.

When running HDMI cables longer than 30 feet, check your cable specifications. HDMI cables loose signal over long distances and your media setup may require a signal booster or HDMI balun.

Once connections are made, the media compartment cover must be secured. Failure to close the media compartment exposes the ports and components to the elements and has the potential to permanently damage electronics.

Screen Health

The 4K liquid crystal panel is a high technology product with 8,294,400 pixels, giving you fine picture details. Occasionally, a few non-active pixels may appear on the screen as a fixed point of blue, green or red. Please note that this does not affect the performance of your product.

Meet Séura® Shade Series™



Shade Series™ Outdoor Display

In the Box



Power Cable



IR Remote
Control

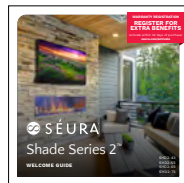

Welcome Guide

Parts

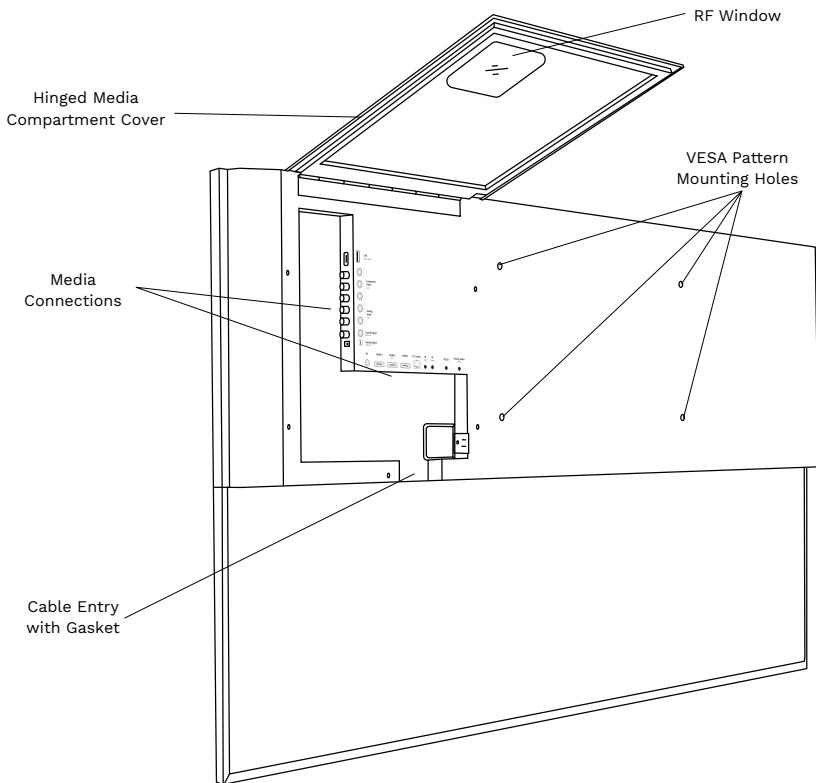

Installing Your Shade Series™

Séura® Shade Series™ is designed to be wall-mounted using the standard mounting hole pattern (VESA) on the back of the display. Use an outdoor-rated wall mount (sold separately) to mount to most outdoor wall surfaces. Follow the instructions with your mount for full details to install your display.

NOTE: Before beginning installation, verify that the weight rating and VESA hole pattern on the mount you purchased is compatible with your outdoor display.

1. Attach the Soundbar (Optional)

Follow the instructions included with your soundbar to attach to your Shade Series.

2. Install the Wall Mounting Brackets (sold separately)

Follow the instructions included with your outdoor-rated wall mount to attach brackets to your display and wall. Before hanging the display, proceed to step 3.

3. Make Media Connections

Make all other preferred media connections inside the media compartment. Turn on the display and verify all media sources.

TIP: In case you decide to add an additional streaming device or media player at a later date, we recommend connecting extra HDMI or other cabling at the time of installation so you won't have to remove the display from the wall to connect.

4. Close Media Compartment Cover

Reattach the media compartment cover. Take care when screwing into place to minimize gaps around cords. At entry, cables should be spaced out to allow the foam seal to completely surround each cable. Bunching the cables together can create gaps in the foam that allow moisture and insects to enter the cabinet that may result in damage.

5. Hang Shade Series on the Wall

Complete installation by hanging Shade Series on the mount according to the mount instructions.



Séura® Shade Series™ outdoor products are engineered for shaded locations. Exposure to direct sunlight has the potential to permanently damage electronics.

Connecting Your Shade Series™

Open the weatherproof media compartment to access all connections. To connect a source such as a streaming device or cable box, connect one end of an HDMI cable (or other, cables not included) into an HDMI port on the display and the other end into your device.

TIP: Ensure your media source is located in a dry location. Housing the device inside the media compartment is not recommended.

USB (DC 5V 0.5A)
Component Video Input
Analog Audio Line In
Coaxial Digital Audio Out
Optical Digital Audio Out
RF
HDMI 3
HDMI 2 ARC
HDMI 1
IP Control
IR Input
IR Output
RS232
Analog Audio Output

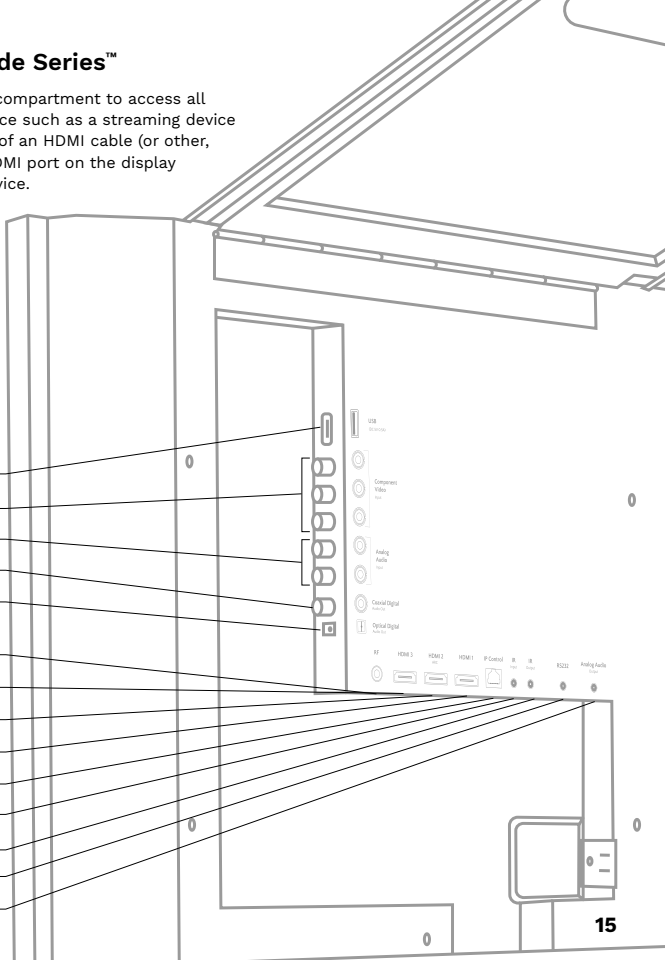

VESA Wall Mounting

Install your wall mount on a solid wall perpendicular to the floor. When attaching to other building materials, please contact your nearest dealer.

If installed on a ceiling or slanted wall, it may fall and result in severe personal injury. We recommend that you use a Séura wall mount when mounting the display to a wall.

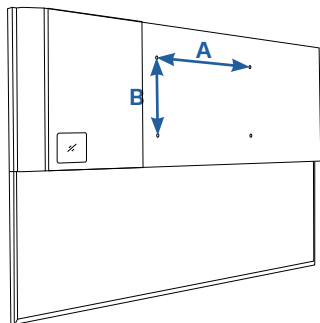

	43 INCH SHD2-43	55 INCH SHD2-55	65 INCH SHD2-65	75 INCH SHD2-75
VESA PATTERN (A x B)	300 x 300mm		400 x 200mm	
STANDARD SCREW	M6	M6	M6	M6



NOTE

Screw length needed depends on the wall mount used. For further information, refer to the instructions included with the mount.

Standard dimensions for wall mounting are shown in the above table.

When purchasing a Séura wall mount, a detailed installation manual and all parts necessary for assembly are provided.

Do not use screws longer than the standard dimension, as they may cause damage to the inside to the display.

For wall mounts that do not comply with the VESA standard screw specifications, the length of the screws may differ depending on their specifications.

Do not use screws that do not comply with the VESA standard screw specifications.

Do not fasten the screws too strongly, this may damage the display or cause the display to fall, leading to personal injury. Séura is not liable for these kinds of accidents.

Séura is not liable for display damage or personal injury when a non-VESA or non specified wall mount is used or the consumer fails to follow the display installation instructions.

Consult with your local dealer for a wall mount that complies with the VESA pattern and weight of your display model. Refer to the instructions provided with your wall mount. Carefully attach the wall mount bracket at the rear of the display. Install the wall mount bracket on a solid wall perpendicular to the floor. If you are attaching the display to other building materials, please contact qualified personnel to install the wall mount. While a S ura wall mount is recommended, ensure that any third party mount is adequately secured to the wall with enough space to allow connectivity to external devices. If you are using a non-adjustable mount, attach the mount to the wall. Attach the cables to the display first, then attach the display to the mount.

Wall Bracket

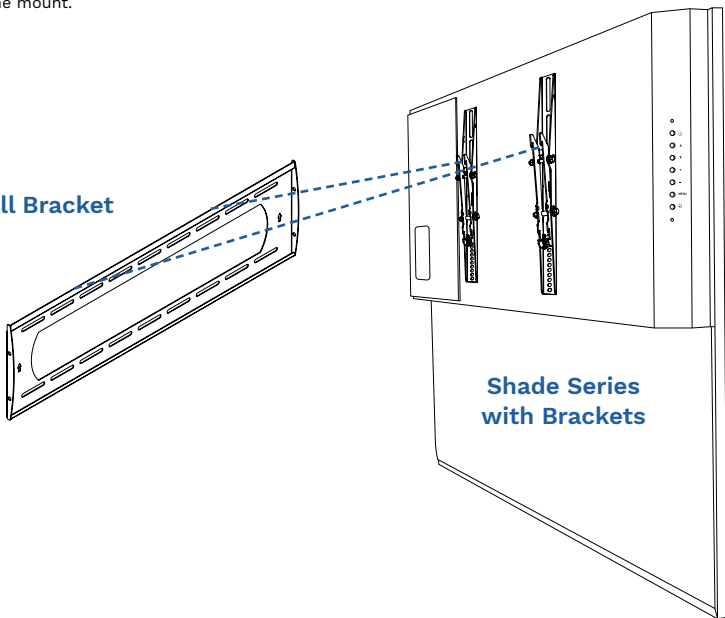

CAUTION: Do not install your wall mount kit while your display is turned on. It may result in personal injury due to electric shock.

CAUTION: Do not allow children to climb on or hang from the display.

Remote Functions

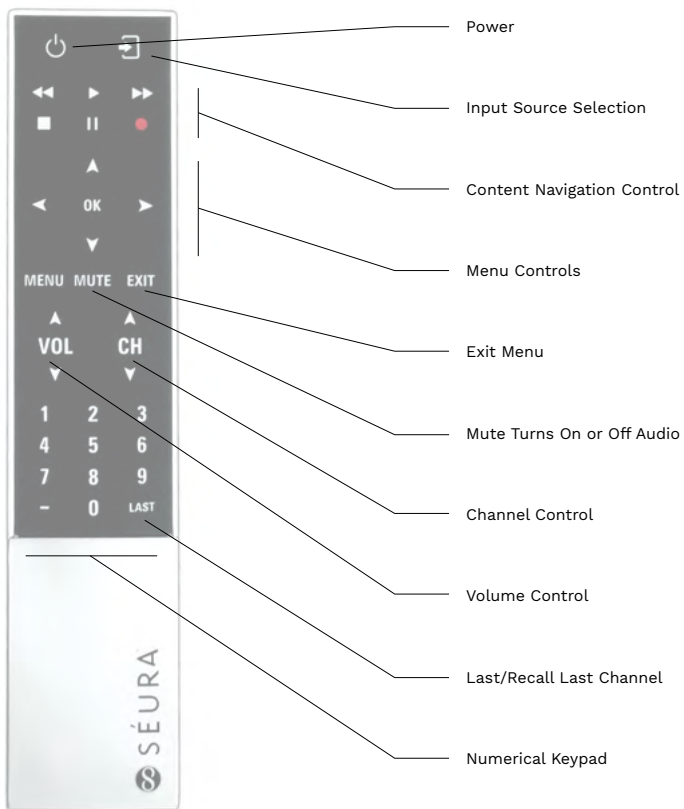

Caring for your Séura® Shade Series™

While Shade Series may be safely exposed to weather and moisture, the use of a Séura Outdoor Cover when not in use is recommended.

Transporting the Display

When transporting Shade Series, never carry it by holding or putting pressure on the screen. Screen pressure may damage the LCD or weaken the waterproof seal. Be sure to always transport with two people supporting it with both hands.

Caring for the Screen

To clean the screen, gently wipe the surface of the front panel with a clean, soft and lint-free cloth. If needed, dampen the cloth with distilled water or isopropyl alcohol and lightly wipe the screen. Do not use force as pressure on the screen may damage the LCD or weaken the waterproof seal. Do not use solvents or chemical cleaners as they may damage the screen. Do not use a garden hose or pressure washer on the display.

Caring for the Cabinet

Clean regularly with a clean, soft and lint-free cloth. Do not use a chemical cloth (wet/dry sheet type cloth). Use a mild detergent, isopropyl alcohol or multi-use cleaner to remove dust and debris. Stubborn stains such as mineral water deposits may be removed with a calcium or lime remover such as CRL®. However, DO NOT allow CRL® to touch the LCD screen as it will distort the surface. Cleaning with an abrasive cloth or using strong force may scratch the surface of the cabinet. Do not apply insecticides or other volatile liquids.

Use of a Séura Outdoor Cover when not in use is highly recommended to protect your display. Do not allow the cabinet to remain in contact with rubber or vinyl products for a long period of time. Plasticizers inside the plastic may cause the cabinet to deform and cause the paint to peel off.



Séura® Shade Series™ Warranty

The standard limited warranty policies of Séura, Inc. ("Séura") shall apply to all equipment or other goods ("Products") at the time of sale to any authorized Séura distributor and/or product reseller. These warranty policies may be modified by Séura from time to time. Copies of the standard limited warranties then in effect for a particular Product will be made available upon request and are also available on the Séura website at <https://www.seura.com/warranty/>. This warranty is valid only with respect to Product sales in the U.S. and Canada.

If any Product fails to work or operate properly because of a defect in materials or workmanship, Séura will, if notified of such defect within the applicable warranty period indicated below, at its option, either: (a) repair the Product with new or refurbished parts onsite or at Séura's factory, including Séura's labor if applicable; or (b) replace the Product with a new or refurbished Product; or (c) if repair or replacement is not commercially feasible, refund an amount equal to a pro rata share of the current MSRP (as determined by the remainder of the warranty period). The remedy chosen will be in good faith and at the discretion of Séura. In no event will Séura be responsible for any costs related to installation and/or removal of Product.

Séura warrants its Products as set forth below, which warranty periods shall start and run from the date of Séura's sale of the Product:

- **Outdoor Displays** with respect to Séura's labor, structure, assembly, display including remote, and power supply for two (2) years.
- **Outdoor Soundbars** with respect to labor and parts for one (1) year.

Exceptions to Warranty: This warranty is valid only with respect to Product sales in the U.S. and Canada. Séura does not warrant Products against defects arising out of, related to, or caused by, whether totally or partially, and whether directly or indirectly, any of the following:

- A. Failing to properly clean and maintain, any Product, part or component of a Product, including, but not limited to, filters, front bezel, and other Product areas or components;
- B. A Product's extended use, including particularly, commercial applications, where a Product is operating on average more than twelve (12) hours per day on a permanent or extended periodic basis;
- C. Circumstances, damage (including concealed damage) or other conditions occurring during shipment of a Product or at any time after a Product leaves Séura's facility (including without limitation transport of the Product to or from Séura before or after authorized service). Products must be packed properly using original packaging or Séura replacement or pre-authorized packaging. Customer assumes all risk, and costs, including transportation costs, while Product is in transit to or from Séura;

D. Circumstances, damage or other conditions occurring during unpacking and/or removal of a Product from its original packaging, including the removal of protective material;

E. Improper, incorrect, or insufficient AC supply voltage to a Product;

F. Alterations, modifications, including use of unauthorized mount, or changes to a Product without Séura's prior written authorization;

G. The incorporation of a Product into or within a product of a third party, without Séura's prior written authorization;

H. A Product's misuse, neglect use, abuse, or improper operation, including the failure to follow a Product's normal and ordinary operating instructions;

I. The effects of fire, flood, lightning, electrical surges, water and other liquid infiltration, smoke, insect or animal infestation, sand, mud, chemicals, improper cleaning agents and other substances not intended to come into contact with a Product, including any such substances contact with a Product as the result of acts of God;

J. The improper or faulty installation, setup, or adjustment of a Product;

K. A Product's repair, attempted repair, or total or partial disassembly by any party other than a Séura authorized service representative;

L. When the Product occurs with pixel errors within the specified and permitted area. (For more information about this, inquire directly with Séura regarding the Séura Pixel Policy.)

M. Corrosion that does not affect the performance of a Product or the reasonable cosmetic appearance of a Product (including without limitation, scratches or other paint or finish damage to a Product that lead to or are caused by, in part or in total, corrosion);

O. Normal wear and tear on the Product.

Séura does not warrant that its Products will integrate with any third party products at present or in the future. It is purchaser's responsibility to test and verify compatibility. Further, Séura does not warrant its software or programs, or any content downloaded after shipment. It is the purchaser responsibility to take precautions to protect the product from malware, viruses, data loss, and other potentially destructive programs.

Warranty Disqualifiers. This Limited Warranty only extends to, and runs for the benefit of, the original purchaser of the Product and only covers a Product purchased new. All warranty claims must be submitted together with original proof of purchase and any Product subject to a warranty claim must retain its original Séura serial number. Séura reserves the right to require any warranty claimant to produce the original

purchase receipt or other original purchase date proof as may be reasonably required by Séura to verify the Product's warranty eligibility. Séura shall have no liability with respect to Products whose serial number has been removed, defaced, replaced, or otherwise tampered with in any manner. Séura reserves the right to examine all failed product components and determine, in its sole discretion, whether any product components are defective and covered under warranty.

LIMITATION OF LIABILITY. THE EXPRESS LIMITED WARRANTIES SET FORTH HEREIN ARE IN LIEU OF ALL OTHER WARRANTIES, WRITTEN OR ORAL, EXPRESSED OR IMPLIED, INCLUDING, BUT NOT LIMITED TO, ANY IMPLIED WARRANTIES OF MERCHANTABILITY OR FITNESS FOR A PARTICULAR PURPOSE OR USE. SÉURA WILL NOT BE LIABLE FOR ANY DAMAGE TO OTHER PROPERTY CAUSED BY ANY DEFECT IN THE PRODUCT, DAMAGES BASED ON INCONVENIENCE, LOSS OF BUSINESS OPPORTUNITY, LOSS OF GOODWILL, INTERFERENCE WITH BUSINESS RELATIONSHIPS, OR OTHER COMMERCIAL LOSS, EVEN IF THE CUSTOMER HAS BEEN ADVISED OF THE POSSIBILITY OF SUCH DAMAGES. SÉURA WILL NOT BE LIABLE FOR ANY LOSS, DAMAGE OR LIABILITY OR ANY DIRECT, INCIDENTAL, INDIRECT, PUNITIVE, SPECIAL OR CONSEQUENTIAL DAMAGES RESULTING FROM THE USE OR MISUSE OF A PRODUCT, OR ARISING OUT OF ANY BREACH, BY THE PURCHASER OF A PRODUCT, OF THIS LIMITED WARRANTY. SÉURA SHALL NOT BE LIABLE FOR ANY CLAIM AGAINST THE CUSTOMER BY ANY OTHER PARTY. SÉURA SHALL NOT BE LIABLE FOR ANY VERBAL WARRANTY ASSURANCES MADE BY ANY EMPLOYEE OR AUTHORIZED DISTRIBUTOR, RESELLER OR INSTALLER THAT CONFLICTS WITH OR ENHANCES THE WRITTEN WARRANTY HEREIN. SOME STATES DO NOT ALLOW THE EXCLUSION OR LIMITATION OF INCIDENTAL OR CONSEQUENTIAL DAMAGES, OR LIMITATIONS ON HOW LONG AN IMPLIED LIMITED WARRANTY LASTS, SO THE EXCLUSIONS MAY NOT APPLY TO A PARTICULAR PURCHASER. NOTWITHSTANDING ANYTHING HEREIN TO THE CONTRARY, SÉURA'S MAXIMUM AGGREGATE LIABILITY RELATED TO ANY WARRANTY CLAIM OR WITH RESPECT TO A PRODUCT SHALL NOT EXCEED THE THEN CURRENT SÉURA WHOLESALE PRICE OF THE SPECIFIC PRODUCT FROM WHICH THE CLAIM DERIVES.

NOTICE OF ANY WARRANTY CLAIM MUST BE RECEIVED BY SÉURA, IN WRITING, PRIOR TO THE EXPIRATION OF THE APPLICABLE WARRANTY PERIOD SET FORTH ABOVE. THE PRODUCT WARRANTY APPLIES ONLY FOR THE PERIODS SET FORTH ABOVE.

Warranty Procedure. A warranty claimant must contact Séura at 920-857-9069 for a diagnostic. Please have your product receipt available. At that time, Séura will provide technical support over the phone to attempt to fix the problem. If unsuccessful, a Séura Representative will determine if the Product will be serviced onsite, replaced, or returned to Séura's factory in Green Bay, Wisconsin for repair. If Séura determines that the Product is not covered under the warranty or damaged in shipping, Séura will notify and inform the purchaser of service alternatives that are available on a fee basis.

Toll-Free Technical Support: Please call 1-800-957-3872 to speak with a Séura Technical Support Representative. Séura Representatives are available Monday-Friday, 8:00am-4:30pm Central Time.

Onsite Service: If Technical Support determines the problem may be fixed onsite, a Séura service agent will be scheduled within 24 hours to service the unit. A Séura representative will work with the customer to schedule a convenient time for onsite service. Parts may be sent to the customer's location. Onsite service is available in the United States during normal business hours Monday – Friday, unless other special circumstances exist and special arrangements are made.

Factory Service: If Technical Support determines the Product must be sent back to Séura's factory for repair, the customer must follow return instructions below. Séura will ship the repaired Product to the authorized reseller, installer or customer's address. This warranty does not cover removal or installation costs of Products.

Advanced Replacement: If Technical Support determines the Product must be replaced, Séura will ship a new Product to the authorized reseller, installer or customer's address. The customer must follow return instructions below to send the damaged Product back to Séura's factory. Credit card information will be collected before shipment of the replacement Product. If Séura does not receive the original Product back within thirty (30) days of shipping the replacement Product, the credit card on file will be charged at full MSRP. This warranty does not cover removal or installation costs of Products.

Return Instructions: If return is necessary, Séura will issue a return goods authorization (RGA) number and, if applicable, specific return and shipping instructions. A Product will only be accepted for warranty claims if returned and shipped to Séura in the Product's original packaging materials. If original packaging is not available, please contact Séura to receive authorized replacement packaging. Packages not bearing the issued returned goods authorization (RGA) number will not be accepted by Séura and will be returned to sender. In addition to the Product, the package must include the warranty claimant's original sales receipt for the purchase of the Product. All Product returns shall be received by Séura, at 1230 Ontario Road; Green Bay, WI 54311 with freight prepaid by the warranty claimant. Séura shall not be responsible for, and the warranty claimant assumes and retains all such responsibility, any damage or loss to or of the Product during shipment to and from Séura as the result of a warranty claim.

Exclusive Remedy. This Limited Warranty sets forth the exclusive remedies of a warranty claimant, and the exclusive liabilities and obligations of Séura, with respect to allegations of a defective Product.

19163121.3

Troubleshooting

If the product is not working properly, please check the following troubleshooting solutions before you contact customer service:

Challenge	Possible Solution
Will Not Power Up	<ul style="list-style-type: none">• Make sure to check that the AC power cable is connected to an outlet and the display• Make sure that the power outlet is receiving power• Try pressing POWER button on the display to make sure the problem is not the remote. <p>If the display turns on, refer to 'Remote control does not work' troubleshooting guide.</p>
Remote Control Not Working	<ul style="list-style-type: none">• Make sure that there is known working batteries in the remote and in the correct polarity• Make sure there are no obstacles in between the IR receiver and the remote (ex. sunlight or tape)• Try pointing the remote directly at the display from 5 feet away.
Signal Issue	<ul style="list-style-type: none">• Check cable connections to ensure they are connected.• Plug the video source directly into the display which will remove any potential issues associated with an extender or matrix switch device. (if applicable)• Replace cables with known working cables.• Make sure the connected devices are powered ON.• Make sure that the source is on the correct INPUT.• Power cycle the video source device by unplugging the device and plugging the device back in.
No Sound	<p>Soundbar</p> <ul style="list-style-type: none">• Make sure your cables are connected properly• Make sure the display is not on MUTE / turn up the volume.• Make sure the soundbar is connected to the power supply <p>External Sound System</p> <ul style="list-style-type: none">• Make sure your cables are connected properly• Make sure the display is not on MUTE / turn up the volume.• Make sure the Digital Audio Settings within the display is not set to OFF• Test the external sound system with another device to ensure that it is working.

For additional technical support, please contact Séura at **1-800-957-3872** during regular business hours: M-F 8:00 am - 4:30 pm, Central Time.

Control Documentation and On Screen Display Menu

To access the in-depth operation manual including menu options and current control documents, please visit www.seura.com/download-center

For additional technical support, please contact Séura at
1-800-957-3872 during regular business hours:
M-F 8:00 am - 4:30 pm, Central Time.



1230 Ontario Road Green Bay, Wisconsin 54311
1-800-957-3872 contacts@seura.com
www.seura.com



LT00018

Publish date: July 21, 2020
Information is subject to change without notice.

© 2020 Séura