

MODEL-ONE

MODULAR STAND SYSTEM

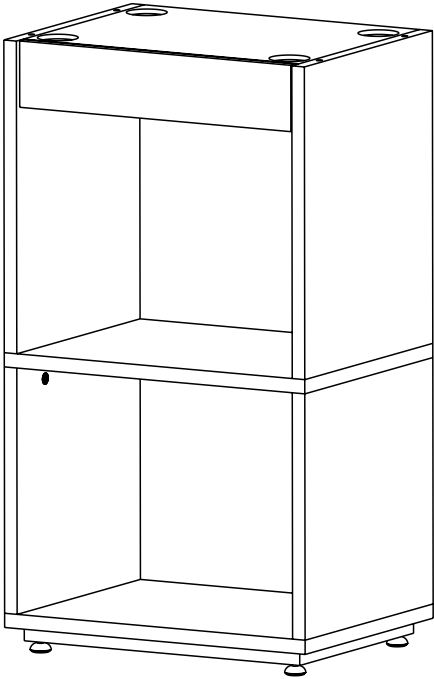

www.andoveraudio.com

Table of Contents

Introduction /Assembly Options.....	4
About Andover / In The Box.....	5
Assembly.....	6
Warranty / Cleaning / Service.....	7
Contact.....	8

Model-One Modular Stand System

The Model-One Modular Stand System is the perfect platform to support the Model-One Turntable Music system. It can also be used with the Andover Spinbase, or any other equipment that fits on its 18" W x 13.5" D top surface. It may be constructed in various combinations to fit your needs.

The Upper-Stand must be combined with either the Lower-Stand, or the Model-One Subwoofer. The resulting unit supports the Model-One Turntable Music system at the ideal listening height in a typical environment.

An accessory glass and hardwood top is available that matches the top of the Subwoofer. It may be purchased separately to trim the top if you do not want to place a component on it, such as when using the stand for additional record storage.

1. Dual-shelf stand.

Connect an Upper-Stand with a Lower-Stand to support your Model-One system with storage for up to 200 LP's.

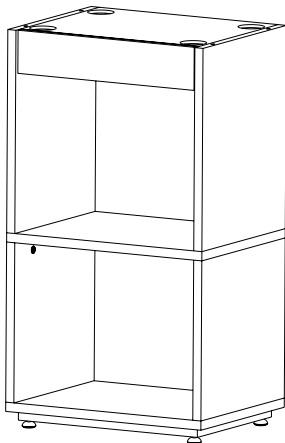

2. Subwoofer + Upper-Stand. Connect an Upper-Stand to the Model-One Subwoofer to create a full-range audio system with storage for up to 100 LP's.

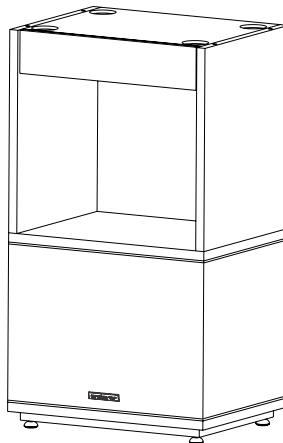

3. Expansion Stand. Add an optional glass top to finish off a free-standing combination for added record storage that perfectly compliments your Model-One system.

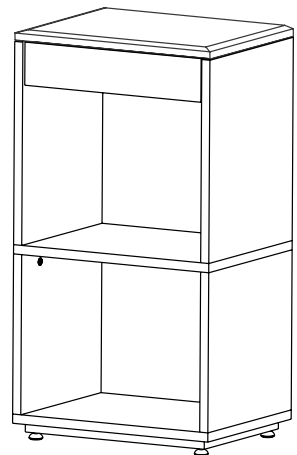

About Andover Audio

Since 2012, Andover Audio has provided behind the scenes design and manufacturing services to some of the most respected brands in automotive, professional, and high-performance consumer audio. We now focus our award-winning skills on our own product line that artfully blends exceptional sound with distinctive design.

In The Box

Upper-Stand

1
Cam-Lock Pins
P/N 1207
Qty:4



2
Locating Dowels
P/N 1208
Qty:4



3
Cam-Lock Cam
P/N 1206
Qty:4



Lower-Stand

4
Leveling Feet
P/N 1224
Qty:4

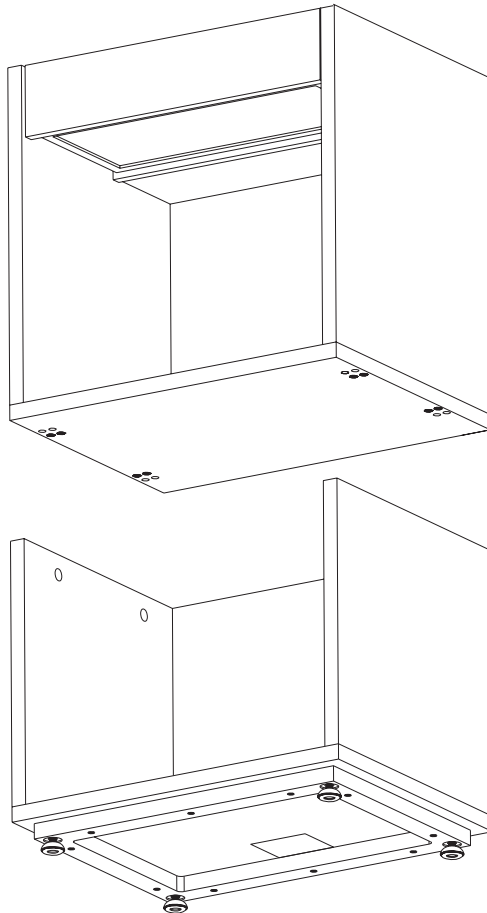

Two-Shelf Assembly

Follow these instructions for standard Two-Shelf assembly. Refer to your Subwoofer manual to attach the Upper-Stand to the Model-One Subwoofer. Begin by placing the Upper-Stand with its top down on a soft surface that will not scratch the top of the stand.

1. Screw the four threaded cam-lock posts (Item 1) fully into four white threaded holes in the bottom corners of the Upper-Stand. If you are attaching the Upper-Stand to a Lower-Stand, use the holes nearest the edge of the stand. If you will be attaching the Upper-Stand to a Model-One Subwoofer, use the four inner holes.

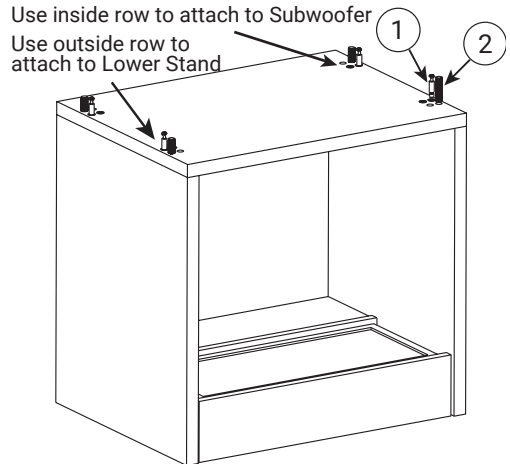

2. Press the wooden Locating Dowels (Item 2) into the slightly larger holes adjacent to the holes you used for the cam lock pins.

3. Place the Lower-Stand with its top down over the pins and dowels you installed in the previous step.

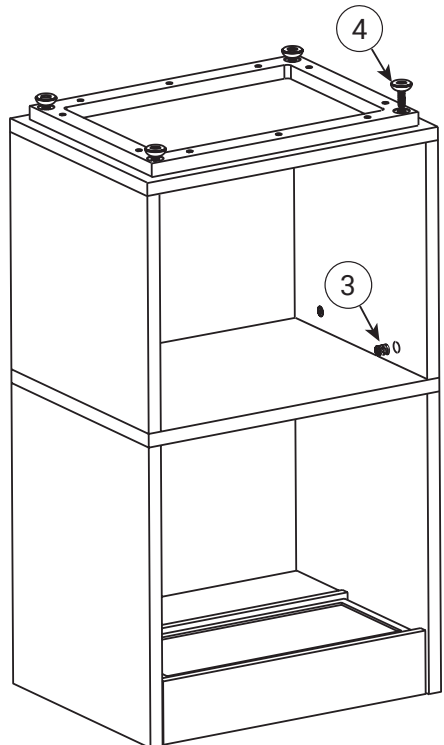

4. Insert a Cam-Lock cam (Item 3) fastener from the inside into each of the Cam-Lock holes and turn each one clockwise to lock the units securely together.

5. Screw the four adjustable feet (Item 4) into the four threaded inserts near the corners of the Lower-Stand. You will be able to screw these in and out individually to level the stand.

6. Flip the assembly over and place it in position. Adjust the feet as necessary to keep the stand level and stable.

Two-Year Limited Warranty

Andover Audio warrants your product against manufacturing defects and workmanship to the initial purchaser for a period of two (2) years from the date of delivery to customer. Andover Audio will repair or replace the unit as necessary to restore proper operation. This warranty covers both parts and labor for the warranty period. The warranty excludes physical damage caused by accident or abuse outside of our control, or if the unit is damaged due to incorrect packing. You are responsible for return shipping. The warranty covers defects but excludes normal wear items such as turntable belts and stylus. If you think you need warranty service, please contact us to obtain an RMA (Return Merchandise Authorization) by e-mailing support@andoveraudio.com or calling 978.775.3670. For more information on returns and exchanges, please visit www.andoveraudio.com/pages/returns-and-exchanges.

If your unit was purchased from a local dealer, contact them first. They may be able to resolve some issues without requiring a return.

An important note about natural wood products

Model-One products and accessories are constructed using natural solid hardwoods and hardwood veneers. While every effort is made to assure consistency in the process and finishing, variation in grain and color is a normal part of the natural beauty that makes each item unique. Because of this, Andover cannot guarantee a perfect match between any two units.

Care and Cleaning

Clean the natural wood surfaces only with cleaning products specifically made for fine furniture and hardwood surfaces. Never use harsh cleaners containing chlorine, or other household "multi-purpose" cleansers. If the finish becomes dull it may be restored to its like-new sheen by careful application of Tung Oil or similar finishing oils.

Service

Should you encounter a problem that you are unable to solve, please contact customer service at support@andoveraudio.com, or the dealer that sold you your unit. If you must return your unit for any reason, it must be safely packed and shipped in its original carton and packing material. Damage that is the result of improper packaging is not covered by the warranty.

Andover Audio subscribes to a program of continuous improvement. As a result, some product features and characteristics may change without prior notice.

Andover Audio, L.L.C.
15 High Street North Andover, Massachusetts 01845
www.andoveraudio.com | support@andoveraudio.com | 978.775.3670

Andover is a registered trademark of Andover Audio L.L.C.
Made in China

1279RA