

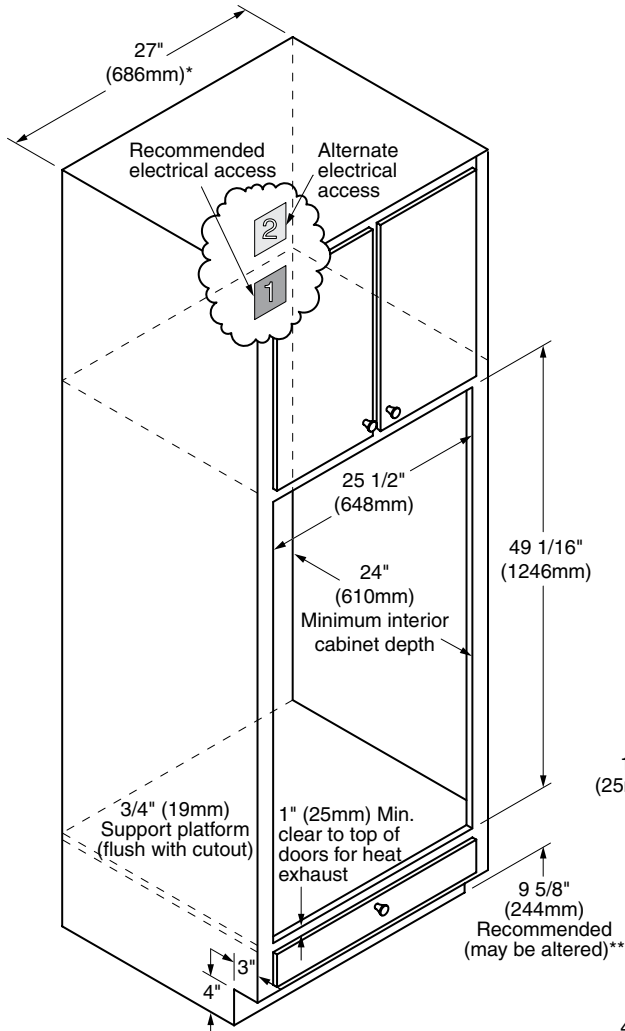

The life of the kitchen™

27" Wide, Double, Electric Wall Oven Specifications

Electrical junction box may be located:
1. In the upper right corner of the cutout.
(See Overall Dimensions below)
2. Above the oven cutout, to the right.



CUTOUT DIMENSIONS

*Maintain a minimum clearance to adjacent cabinet doors/drawers of 1/8" (3mm).

**Positions the open door approximately 36" (914mm) above the floor (Typical counter height).

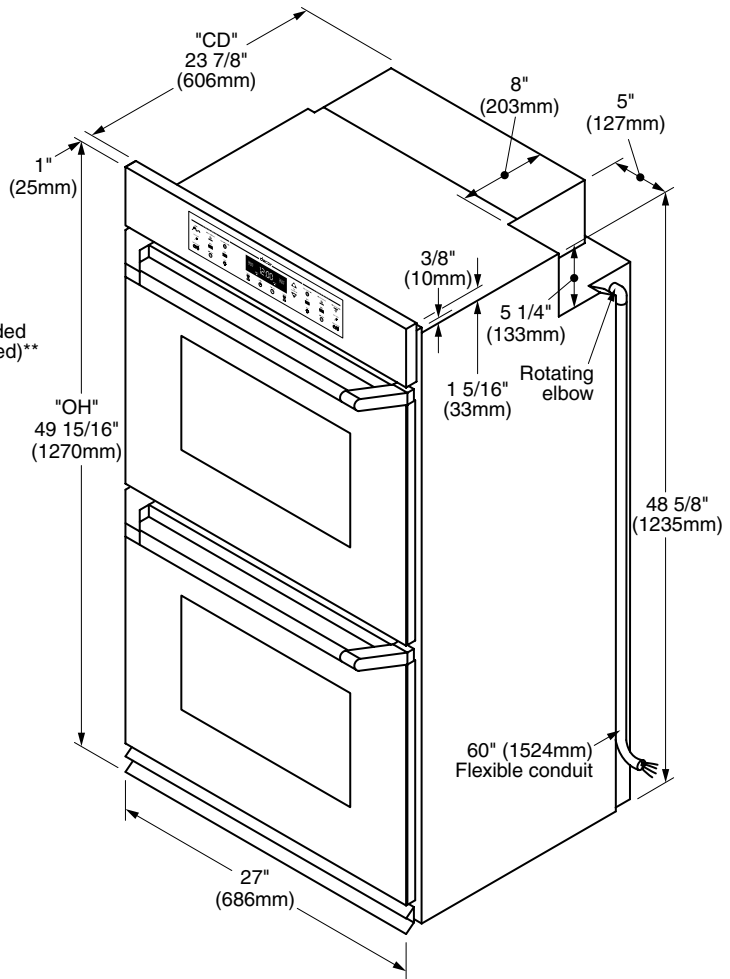

OVERALL DIMENSIONS (ECS227 Shown)



Specifications are subject to change without notice. See installation instructions for additional details.

Dacor®
www.dacor.com
Corporate Phone: 800-793-0093
Planning Faxback: 800-793-0093 ext. 3806



The life of the kitchen™

27" Wide, Double, Electric Wall Oven Specifications

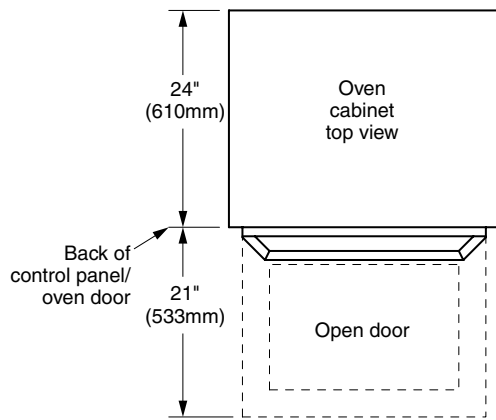

TOP VIEW
(ECS227 Shown)

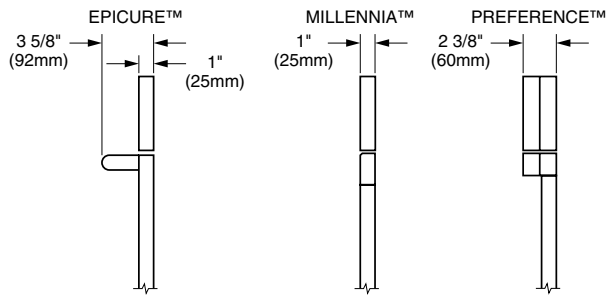

OVEN HANDLE DIMENSIONS

**ECS227, PCS227, MCS227
ECD227, PCD227, MCD227**

P L A N N I N G G U I D E

1.6

SPECIFICATIONS	MEASUREMENTS
Overall Oven Width	27" (686mm)
Overall Oven Height (OH)	49 15/16" (1270mm)
Oven Chassis Depth (CD)	23 7/8" (605mm) from back of control panel
Inside Oven Cell	21"w (576mm) x 15"h (381mm) x 18 1/2"d (470mm)
Cabinet Cutout Width	25 1/2" (648mm)
Cabinet Cutout Height	49 1/16" (1246mm)
Minimum Interior Cabinet Depth	24" (610mm)
Minimum Cabinet Width	27" (686mm)*
Oven Overlays Cabinet Cutout	3/4" (19mm) Each side; 13/16" (21mm) Top, 1/16" (1mm) Bottom
Electrical Supply Requirements	240VAC 4-wire, 60Hz, 40A Dedicated Circuit
Total Connected Load	8.1kW (34A)
Approximate Shipping Weight	337 pounds
Note	*Maintain a minimum clearance to adjacent cabinet doors/drawers of 1/8" (3mm).



Specifications are subject to change without notice.
See installation instructions for additional details.

Dacor®
www.dacor.com
Corporate Phone: 800-793-0093
Planning Faxback: 800-793-0093 ext. 3806