



INSTALLATION INSTRUCTIONS FOR PART 99-7581

APPLICATIONS

2005 Nissan Pathfinder

2005 Nissan Frontier

2005 Nissan Xterra

99-7581

KIT FEATURES

- DIN Head unit provisions with pocket
- ISO DIN Head unit provision with pocket
- Double DIN Head unit provision

KIT COMPONENTS

A) Radio Housing | B) ISO Brackets | C) Trim Plate | D) Double DIN Trim Plate

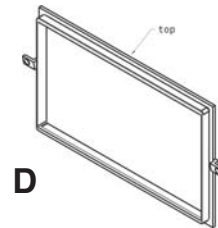
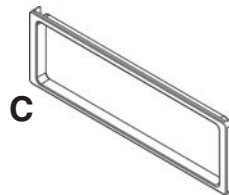
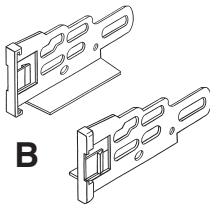
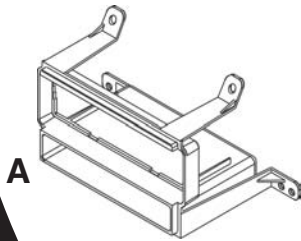

TOOLS REQUIRED:

T20 Torx Driver | Small Flat Blade Screwdriver | Phillips Screwdriver

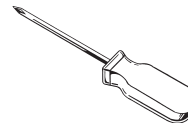
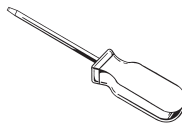
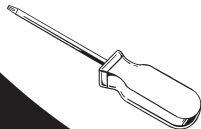

1-800-221-0932



www.metraonline.com

© COPYRIGHT 2004 METRA ELECTRONICS CORPORATION



99-7581

TABLE OF CONTENTS

DASH DISASSEMBLY

2005 Nissan Pathfinder	1
2005 Nissan Frontier /Xterra	2

KIT ASSEMBLY

DIN Head Unit Provisions	3
ISO DIN Head Unit Provisions	4
Double DIN Head Unit Provisions	5

<u>FINAL ASSEMBLY</u>	6
------------------------------------	----------

2005 PATHFINDER

NOTE:

Do not cycle the key while the dash is removed or the air bag light will come on.

- 1** Disconnect the negative battery terminal to prevent an accidental short circuit.
- 2** Unclip and remove trim panel from around cup holders in the center console. (Figure A)
- 3** Unclip and remove shifter trim panel including pocket below radio and a/c controls. (Figure B)
- 4** Unclip and remove panel at top of radio and remove (1) Phillips screw underneath. (Figure C)
- 5** Unclip and remove entire trim panel surrounding radio and including a/c controls. (Figure D)
- 6** Remove (4) Phillips screws securing radio to remove. (Figure E)

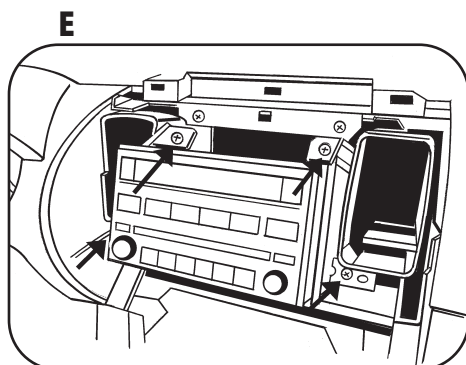
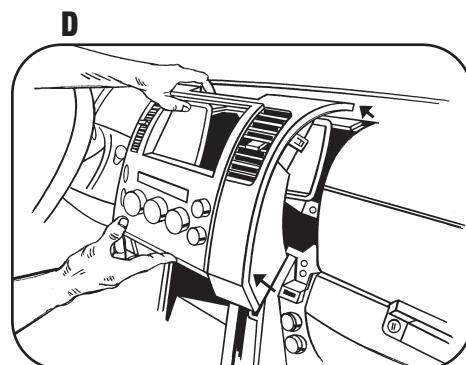
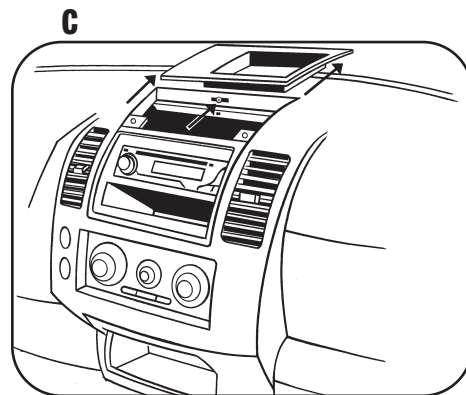
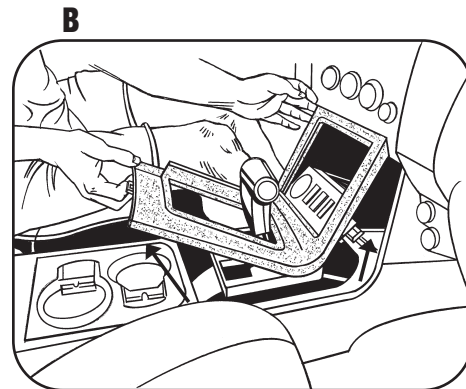
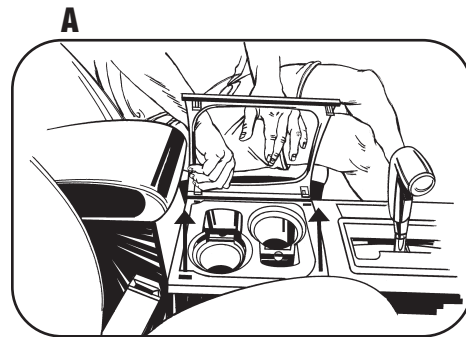

DASH DISASSEMBLY

DASH DISASSEMBLY

2005 FRONTIER/XTERRA

NOTE:

Do not cycle the key while the dash is removed or the air bag light will come on.

- 1 Disconnect the negative battery terminal to prevent an accidental short circuit.
- 2 Unclip and remove panel at top of radio and remove (1) Phillips screw underneath. (Figure A)
- 3 Unclip and remove entire trim panel surrounding radio and including a/c controls. (Figure B)
- 4 Remove (4) Phillips screws securing radio to remove. (Figure C)

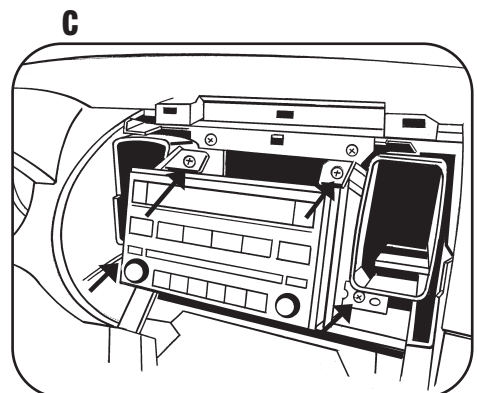
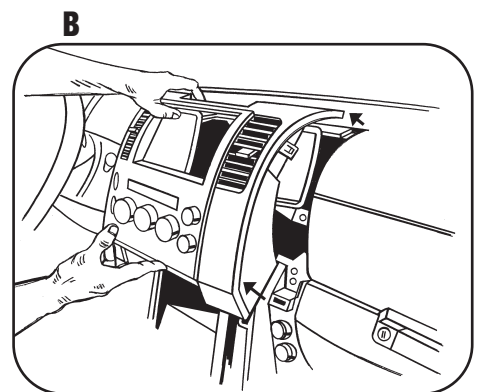
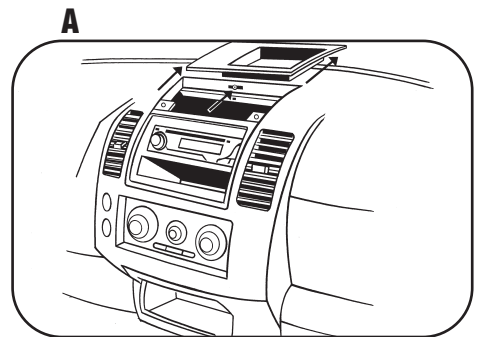

DIN HEAD UNIT PROVISIONS

- 1 Slide the DIN cage into the radio housing and secure by bending the metal locking tabs down. (Figure A)
- 2 Slide the aftermarket head unit into the cage and secure. (Figure B)

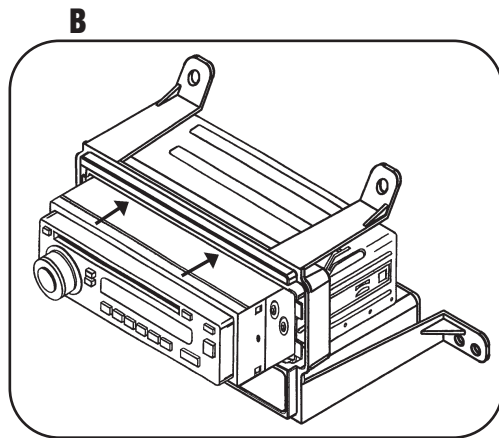
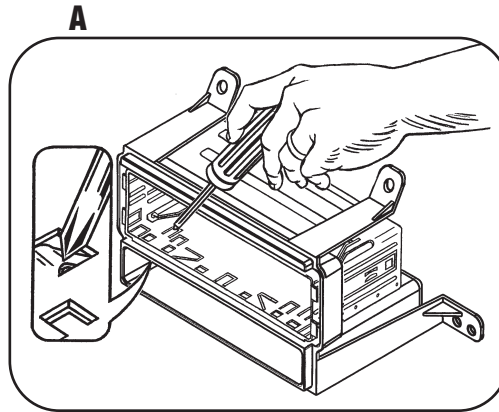

KIT ASSEMBLY

ISO DIN HEAD UNIT PROVISIONS

- 1 Mount the ISO brackets to the head unit with the screws supplied with the unit. (Figure A)
- 2 Slide the head unit into the radio opening until the side clips engage. (Figure B)
- 3 Snap the trim plate into the radio housing. (Figure B)

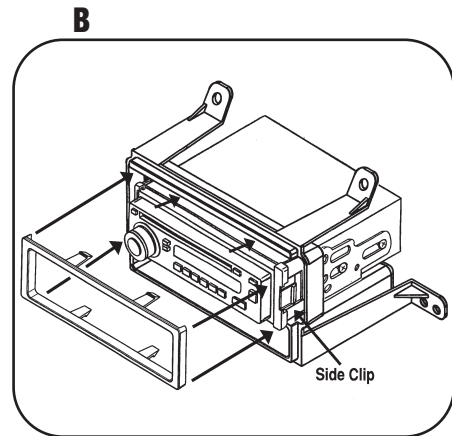
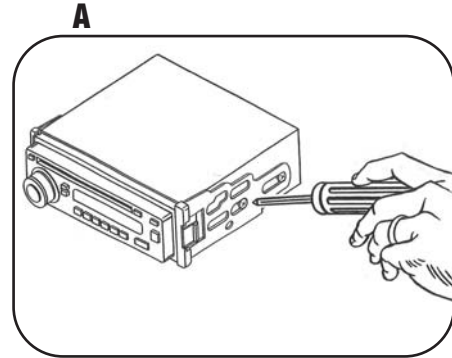

DOUBLE DIN HEAD UNIT PROVISIONS

- 1** Mount the factory brackets onto the aftermarket radio using the hardware supplied with the new radio.
- 2** Remove the (2) T-20 Torx screws from the factory a/c vents in the factory radio trim panel that will secure the DDIN trim plate. (Figure A)
- 3** Secure the DDIN trim plate to the factory radio trim panel using the (2) T20 Torx screws removed in step 2.

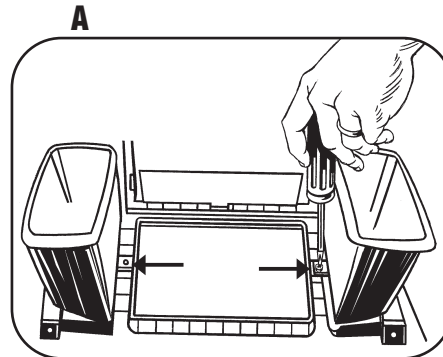

FINAL ASSEMBLY

- 1** Locate the factory wiring harness in the dash and make the connection as shown. Metra recommends using the proper mating adapter and making the connections as shown. (Isolate and individually tape off the ends of any unused wires to prevent electrical short circuit.)
- 2** Re-connect the negative battery terminal and test the unit for proper operation.
- 3** Reassemble radio and dash assemblies in reverse order of disassembly.

FINAL WIRING CONNECTIONS

Make wiring connections using the EIA color code chart shown below and the instructions included with the head unit. Metra recommends making connections as shown below; Strip, Splice, Solder, Tape. Isolate and individually tape off ends of any unused wires to prevent electrical short circuit.

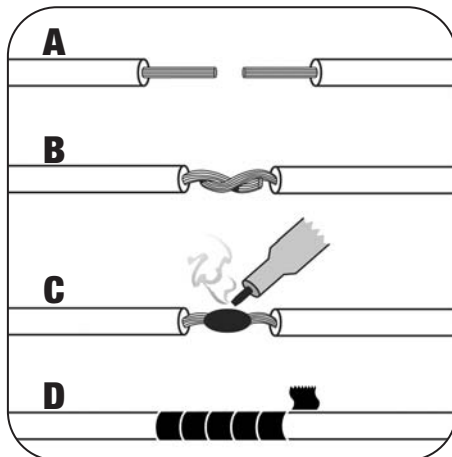

- A) Strip wire ends back 1/2"**
- B) Twist ends together**
- C) Solder**
- D) Tape**

METRA / EIA WIRING CODE

12V Ignition / Acc . . . Red	Right Front (+) Gray
12V Batt / Memory . . Yellow	Right Front (-) Gray / Black
Ground Black*	Left Front (+) White
Power Antenna Blue	Left Front (-) White / Black
Amp Turn-On Blue / White	Right Rear (+) Violet
Amp Ground Black / White	Right Rear (-) Violet / Black
Illumination. Orange	Left Rear (+) Green
Dimmer Orange / White	Left Rear (-) Green / Black

***NOTE:** When Black a wire is not present, ground radio to vehicle chassis.
All colors may not be present on all leads due to manufacturer's specifications.