

LIFESTYLE[®] RoomMate[®]

POWERED SPEAKER SYSTEM



Owner's Guide





SAFETY INFORMATION

Please read this owner's guide

Please take the time to follow the instructions in this owner's guide carefully. It will help you set up and operate your system properly and enjoy all of its advanced features. Please save this owner's guide for future reference.

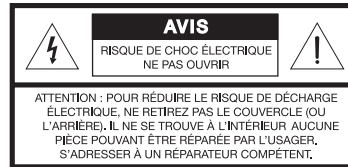
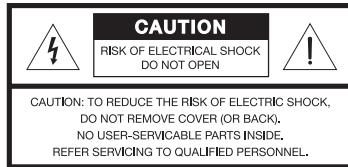
-  **WARNING:** To reduce the risk of fire or electrical shock, do not expose the product to rain or moisture.
-  **WARNING:** The apparatus shall not be exposed to dripping or splashing, and objects filled with liquids, such as vases, shall not be placed on the apparatus. As with any electronic product, use care not to spill liquids into any part of the system. Liquids can cause a failure and/or a fire hazard.
-  **WARNING:** No naked flame sources, such as lighted candles, should be placed on the apparatus.



 The lightning flash with arrowhead symbol, within an equilateral triangle, alerts the user to the presence of uninsulated dangerous voltage within the system enclosure that may be of sufficient magnitude to constitute a risk of electric shock.

 The exclamation point within an equilateral triangle alerts the user to the presence of important operating and maintenance instructions in this owner's guide.

Notes:

- The product label is located on the bottom of the product.
- This product is intended to be used only with the power supply provided.
- Where the mains plug is used as the disconnect device, such disconnect device shall remain readily operable.
- This product must be used indoors. It is neither designed or tested for use outdoors, in recreation vehicles, or on boats.
- Unauthorized modification of the radio remote control could void the user's authority to operate this equipment.

 The RoomMate® powered speaker conforms to the EMC directive 89/336/EEC and to the Low Voltage Directive 73/23/EEC. The PERSONAL® music center II conforms to the RTTE Directive 99/5/EC (R+TTED). The complete Declarations of Conformity can be found on www.bose.com.



Please dispose of used batteries properly, following any local regulations. Do not incinerate.

Additional safety information

See the additional instructions on the **Important Safety Instructions** sheet (North America only) enclosed in the shipping carton.

INTRODUCING THE ROOMMATE® POWERED SPEAKER	5
Before you begin	5
Unpacking	5
Rear panel features	6
Front panel mute switch	6
SETUP	7
Connecting the speaker to your LIFESTYLE® system	7
Making the power connections	8
Installing batteries in the PERSONAL® music center II	9
Adding an external audio source	10
Changing the room code for your RoomMate® speaker system	11
USING THE PERSONAL® MUSIC CENTER II	12
Your control options	12
Confirm that current settings are right	12
Basic controls	13
Getting to what you want	13
What appears on the display	14
What you can do in the source display	14
Display symbols	15
Setup button: use as needed	15
Buttons to use while you listen	16
Adjustable features of the PERSONAL® music center II	17
To change settings for a feature	17
The importance of room codes	18
When to change the room code	19
Why would you change the house code?	19
Audio streams multiply your options	20

LISTENING TO YOUR LIFESTYLE® SYSTEM 21

Performance at your command 21

Playing stored music 21

Searching the library of stored music 23

Using the radio 24

Playing a CD 26

Playing a DVD or VCD 27

Listening to other sources 29

Listening to Your Local Source 29

CARE AND MAINTENANCE 30

Troubleshooting 30

Cleaning 31

Contacting customer service 31

Limited warranty 31

Technical information 31

For your records

Please record the serial numbers of your RoomMate® speaker and PERSONAL® music center II here and on your Product Registration Card. This provides easy access to this information if you ever need to contact Bose® Customer Service.

RoomMate® speaker serial number: _____

PERSONAL® music center II serial number: _____

Dealer name: _____

Dealer phone: _____ Purchase date: _____

Be sure to fill out your Product Registration Card and mail it to Bose. Failure to do so does not affect your limited warranty. Please keep your sales receipt and product registration together with this owner's guide.

INTRODUCING THE ROOMMATE® POWERED SPEAKER

Before you begin

Thank you for purchasing a LIFESTYLE® RoomMate® powered speaker system, a small speaker system that delivers surprisingly great sound. This speaker system provides a simple and elegant solution for enjoying the sound from your LIFESTYLE® home entertainment system in your living room, kitchen, bedroom or any other room in your home.

This product works with LIFESTYLE® 48, 38, 28 Series II and 18 Series II DVD home entertainment systems.

An AUX IN jack on the rear panel allows you to listen to an external audio device through this remarkable speaker, even if it is disconnected from your home entertainment system.

Unpacking

Check the carton for all of the parts shown in Figure 1 and save the carton and packing materials. The original packing materials provide the safest way to transport this product.

If any part of the product appears to be damaged, do not attempt to use it. Contact your authorized Bose dealer immediately or call Bose Customer Service. Refer to the address list enclosed in the carton for phone numbers.

Figure 1

Carton contents

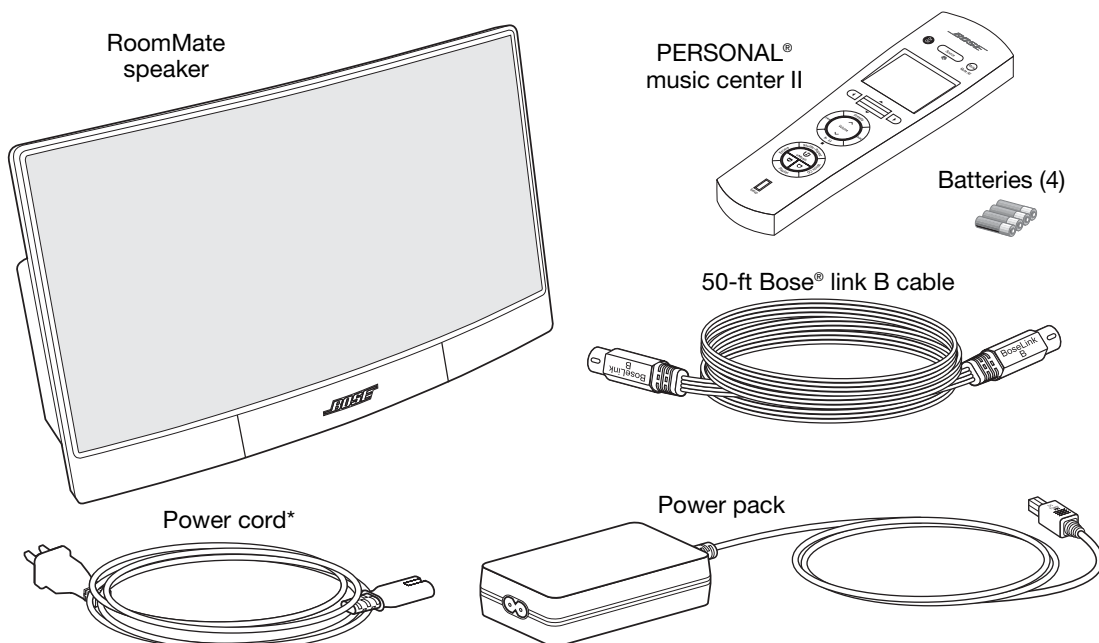

* The appropriate power cord for your region is provided.

🎵 **Note:** Now is a good time to find the serial number on the bottom of your RoomMate speaker and record it on page 4.

INTRODUCING THE ROOMMATE® POWERED SPEAKER

Rear panel features

The rear panel provides a power connector, audio input connectors, and room code switches.

Figure 2

RoomMate® speaker rear panel

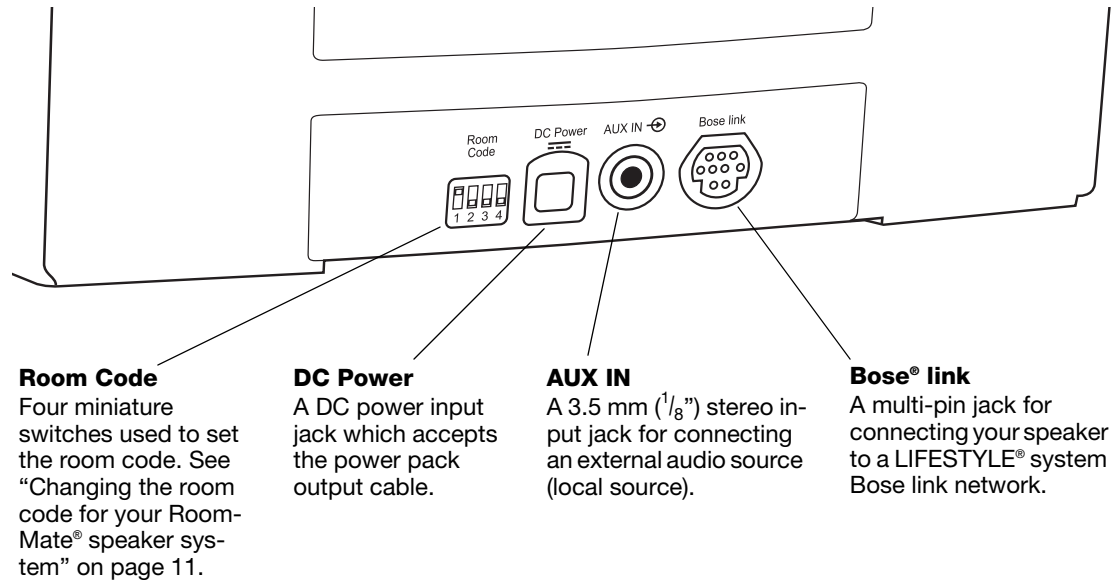
**Front panel mute switch**

The bottom front center of the speaker enclosure contains a touch-sensitive mute switch. To mute or unmute the speaker, just touch the Bose logo.

Figure 3

RoomMate speaker mute switch location

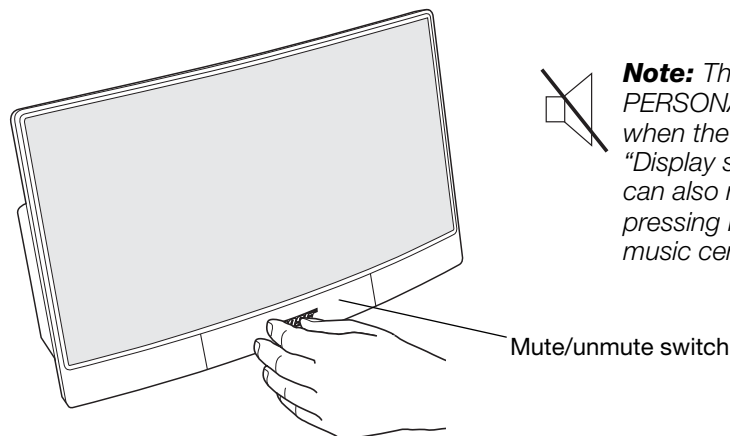

Connecting the speaker to your LIFESTYLE® system

Using the supplied Bose® link “B” cable, connect your RoomMate® speaker to the media center as shown in Figure 4.

Your LIFESTYLE® RoomMate® speaker is shipped from the factory already set up to operate in a Bose link network using room code I. If room code I is already assigned to another Bose link product in your home, you will need to change the room code. For more information, see “Changing the room code for your RoomMate® speaker system” on page 11.

Figure 4

RoomMate speaker to media center connection

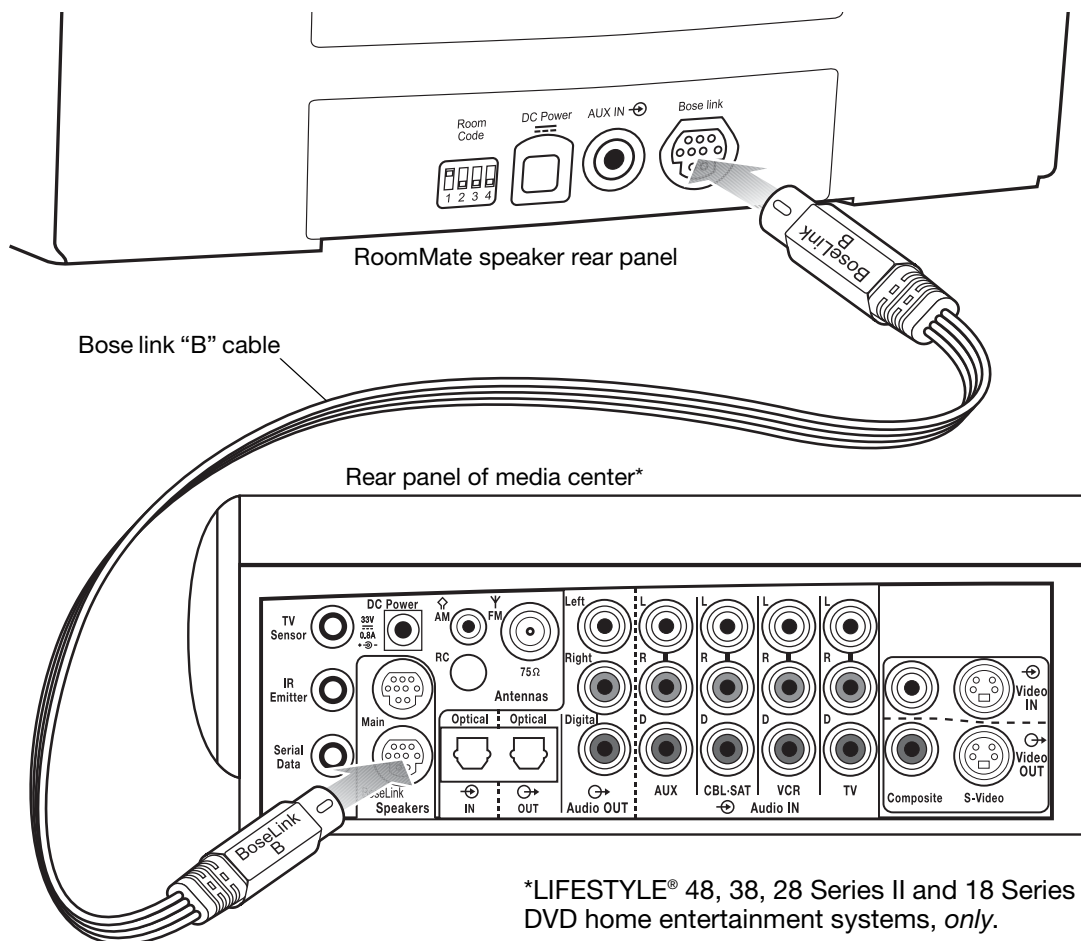

*LIFESTYLE® 48, 38, 28 Series II and 18 Series II DVD home entertainment systems, *only*.

If you already have one Bose® link product

If you already have a Bose® link cable plugged into the Bose link speakers jack, you will need to obtain a Bose link extension/expansion cable. This will enable you to connect both your existing Bose link cable and your new Bose link B cable to your media center.

Another solution is to purchase the AL8 Homewide Wireless Audio Link. This product can provide wireless communication to both your existing Bose link product and your new LIFESTYLE® RoomMate speaker system.

For more information on either of these solutions, contact Bose Customer Service. Refer to the Bose address list included with your LIFESTYLE® home entertainment system.

SETUP

Making the power connections

1. Insert the DC power cord from the power pack into the **DC Power** jack on the rear panel of the RoomMate® speaker. Make sure the **DC Power** label faces up (Figure 5).
2. Insert the small connector of the AC power cord into the power pack. Plug the other end into an appropriate AC receptacle.

The speaker is now in standby mode, ready to use. Turn to “Installing batteries in the PERSONAL® music center II” on page 9.

Figure 5

RoomMate speaker power connections

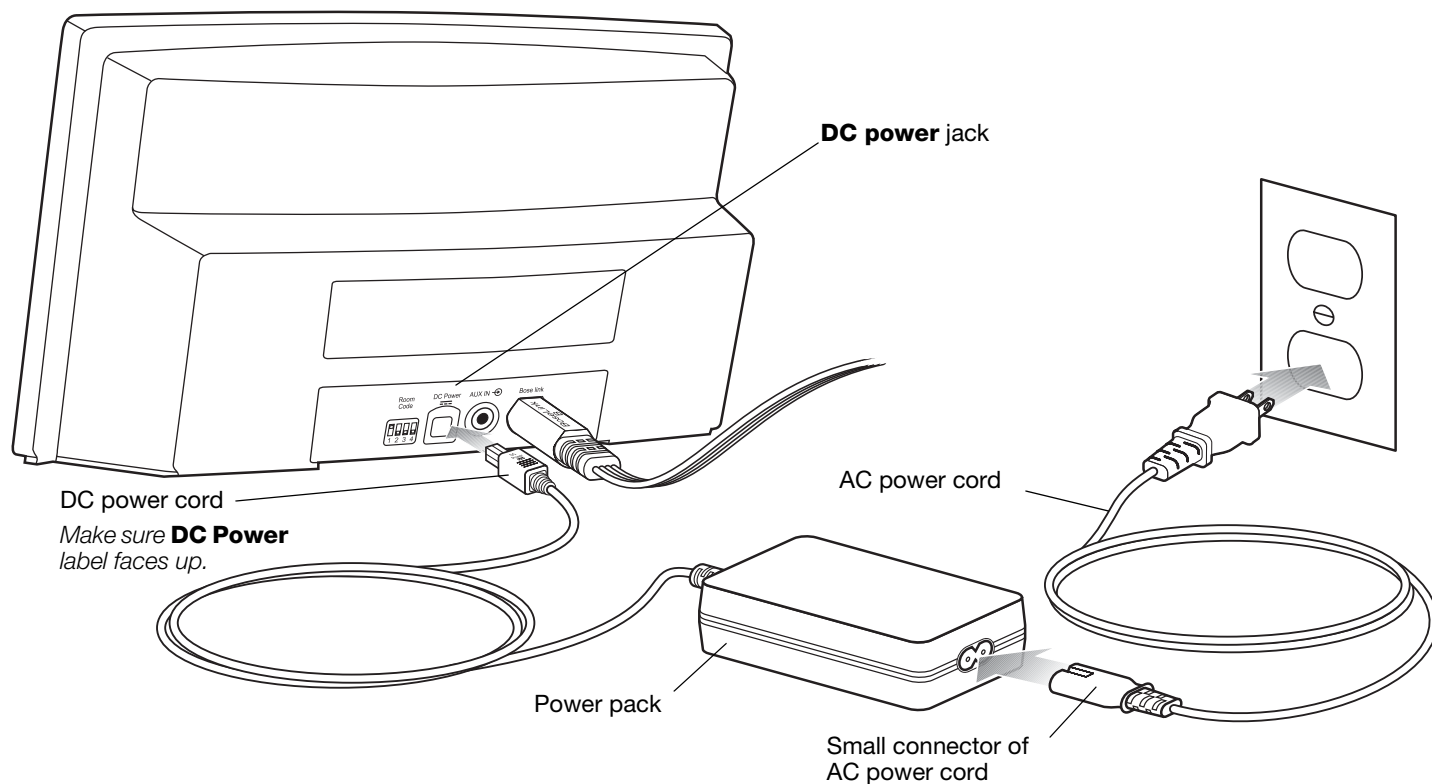

Installing batteries in the PERSONAL® music center II

The PERSONAL® music center II is shipped from the factory already set up to operate your system using room code I. If room code I is already assigned to another Bose® link product in your home, you will need to change the room code. Refer to “When to change the room code” on page 19.

🎵 **Note:** Make sure the room code assigned to your PERSONAL® music center II is the same room code assigned to your RoomMate® speaker system. See “Changing the room code for your RoomMate® speaker system” on page 11.

To begin using your PERSONAL® music center II with your LIFESTYLE® system, just install the supplied batteries as follows:

1. On the back of the PERSONAL® music center II, slide the battery compartment cover off (Figure 6).
2. Install the four AA (IEC LR6) batteries, matching the polarity markings (+ and –) to the markings inside the battery compartment (Figure 6).
3. Slide the battery cover back into place.

Figure 6

Inserting the batteries

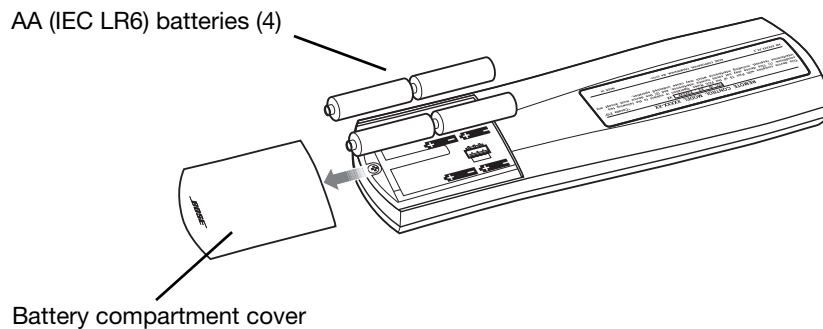

Your PERSONAL® music center II is now ready to operate your LIFESTYLE® system. For operating instructions, refer to “Using The PERSONAL® Music Center II” on page 12.

🎵 **Note:** Change the batteries when you notice a marked decrease in the range or response of your PERSONAL® music center II, or when the battery indicator reads low (see “Display symbols” on page 15).

Adding an external audio source

You can use your RoomMate® speaker to listen to an external audio source such as a TV, or a portable CD or MP3 player. Just plug the output cable from your source into the The AUX IN jack on the rear panel of your speaker. The cable must be equipped with a male 3.5 mm ($\frac{1}{8}$ ") stereo plug.

For operating instructions on listening to an external audio source, refer to “Listening to Your Local Source” on page 29.

🎵 **Note:** The PERSONAL® music center II will not operate any external audio device connected to the AUX IN jack.

Using an external source without a Bose® link connection

When your RoomMate speaker is disconnected from a Bose link network, the AUX IN source is automatically selected. This means that you can listen to an external audio source without using your PERSONAL® music center II. Use the volume control on your external device to set the volume level of the speaker. You can still use the mute switch on the front of the speaker to mute the audio at any time.

Figure 7

Auxiliary audio source connection

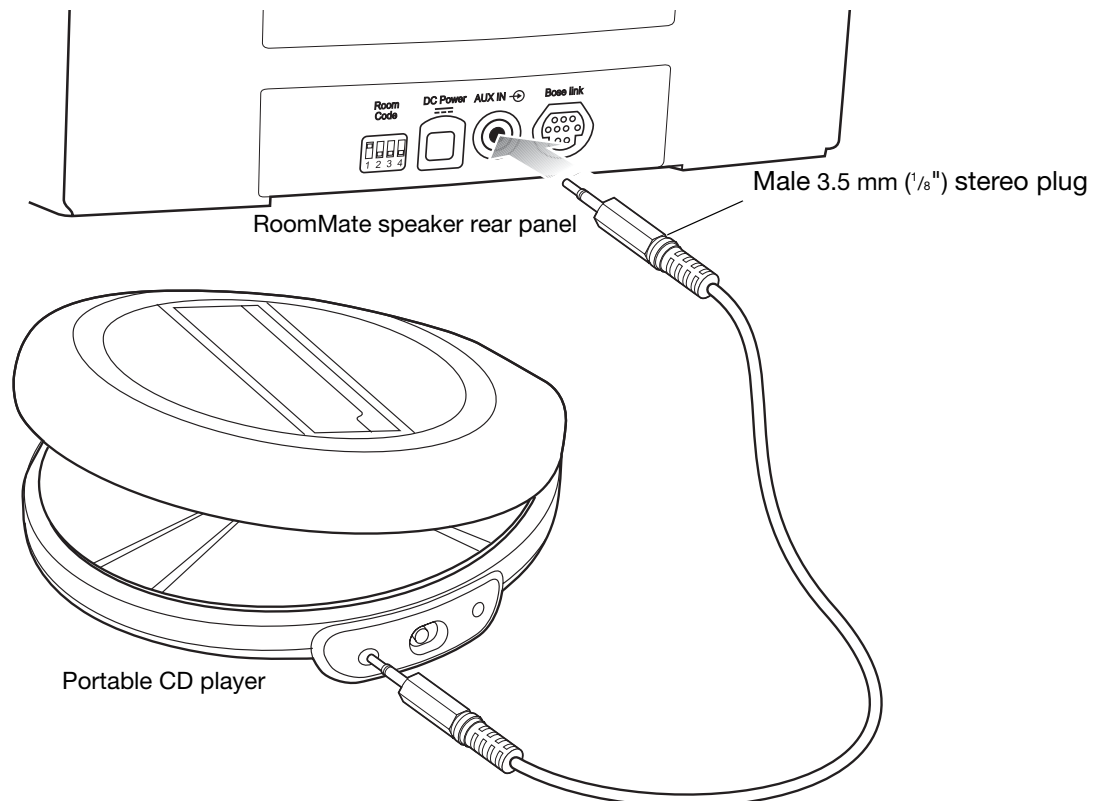

Changing the room code for your RoomMate® speaker system

Each Bose® link product connected to your LIFESTYLE® home entertainment system needs to have a unique room code. This code is what enables the PERSONAL® music center II to operate your LIFESTYLE® system from a Bose® link room (a room in which a Bose® link product is used).

Your LIFESTYLE® RoomMate® speaker is shipped from the factory already set up to operate in a Bose® link room using room code I. If room code I is already used by another Bose® link product in your home, you will need to change the room code. To do this, refer to Figure 8 and set the room code switches for the room code you want to use.

Note: Make sure the room code assigned to your RoomMate speaker system is the same room code assigned to your PERSONAL® music center II. See “When to change the room code” on page 19.

Figure 8

Room code switch settings

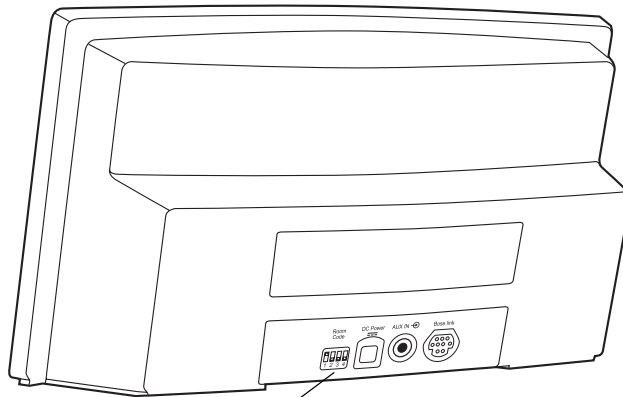

Room code switches

Room

B



C



D



E



F



G



H



Room

I

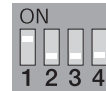

J



K



L



M



N



O



USING THE PERSONAL® MUSIC CENTER II

Your control options

The PERSONAL® music center II opens the door to a variety of new options for playing your LIFESTYLE® DVD home entertainment system in almost any area of your home.

This PERSONAL® music center II provides you with:

- Control of your LIFESTYLE® (18 or 28 Series II or the 38 or 48) system from a different room or floor of your house.
- On-screen information about your stored music and the uMusic™ intelligent playback system choices for enjoying it (on LIFESTYLE® 38 or 48 systems, only).
- The option to readily switch between the two audio streams from the system and multiply your choice of programs.
- Control of speakers set up in the same area as the remote.
- Easy access to system options, which appear right on the remote control screen.
- Instant confirmation of your selection, because you not only hear, but also see what you've selected on the display screen.

Confirm that current settings are right

Your PERSONAL® music center II is set up at the factory for compatibility, as follows:

- To control the sound from a LIFESTYLE RoomMate® speaker connected to the Bose® link output on your LIFESTYLE system media center.
- A house code identical to the one given every new LIFESTYLE® system. For details, see "Why would you change the house code?" on page 19.
- To receive Audio stream 2, which is different from the stream that delivers sound in the main room where the LIFESTYLE® media center is located. For details, see "Audio streams multiply your options" on page 20.
- English as the language used for display text.

With a LIFESTYLE® system previously set up and used with another language, your PERSONAL® music center II detects the difference (only the first time you turn it on), and pauses operation to switch to that language.

♪ **Note:** To learn how to select a different text display language for your system, refer to "Media center options" in the Operating Guide that came with the system.

If the above settings are right, you can begin to use your PERSONAL® music center II now.

♪ **Note:** To change any settings, refer to "Adjustable features of the PERSONAL® music center II" on page 17.

Basic controls

Using just a few selection buttons and the display screen, you can see, choose from, and enjoy a wide variety of LIFESTYLE® system capabilities in your Bose® link room.

Remember that you can use the PERSONAL® music center II, with no need to aim it, all around your home, even outside. Its radio frequency (RF) signals can reach the system from as far away as 80 feet (24.4 meters).

Getting to what you want

The few buttons explained below will enable you to get started, move around on the display screen, and make selections from the display.

See how quickly you get a feel for what happens.

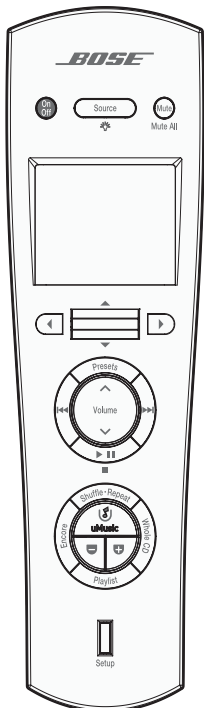

- Turns on your RoomMate® speaker in the Bose link room.
- Alerts your LIFESTYLE® system media center in the main room.
- Activates the last used source at its previous volume level and preset.
- Turns off the current source, the PERSONAL® music center II, and your RoomMate speaker in the Bose link room.

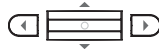

Moves around on the display.

- *Tipping the center bar* up or down moves up or down.
- *Pressing a left or right arrow* button moves left or right.

Increases or decreases selection values.

- *Tipping the center bar* up or down adds to or subtracts from a value (for example, the frequency of the FM stations).

There are guides at the bottom of the display (Figure 9) showing which arrows to use for other actions.

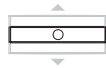

Confirms a selection.

Pressing in on the center bar completes your action and moves to the next choice.



Shows the sources you can choose to hear.



Pressing and holding this button turns the display backlight off and on.

What appears on the display



Press **Source** to see the list of the available sources (Figure 9).

Your list may look different, depending on the type of system you have. (For instance, Stored will appear only if you have a LIFESTYLE® 38 or 48 system.)

Figure 9

Source display

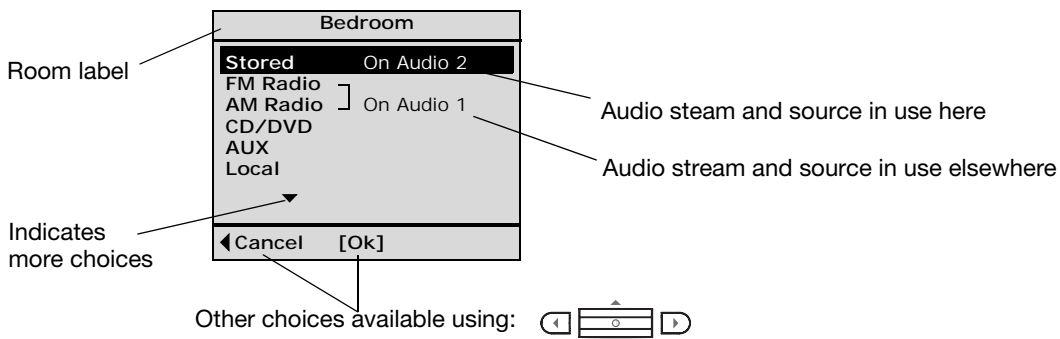

Audio 2, the stream selected to deliver sound to the Bose® link room speakers when the PERSONAL® music system commands it to, appears briefly in the line for Room label, also.

Note: To understand what Audio 1 and 2 mean, refer to "Audio streams multiply your options" on page 20.

What you can do in the source display

- Move up or down to highlight a preferred source.
- Confirm your new choice [OK].
- Move left to return to a previous display.

When you confirm or cancel a choice, the display changes to information about the source that is playing now (Figure 10).

Figure 10

FM radio display

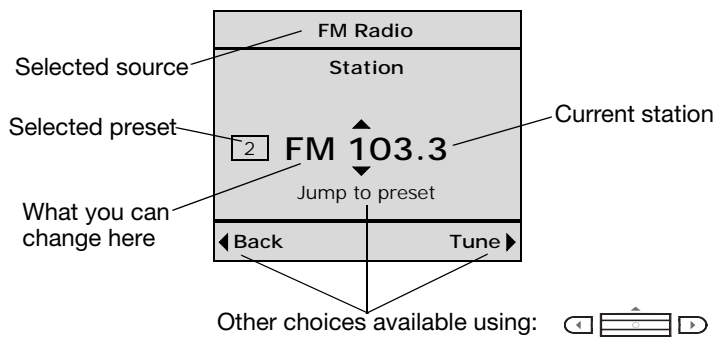

When you see the display above, you may:

- Change the station selected by using the up and down arrows, which move forward or backward through the preset stations.
- Confirm a new selection by pressing in on the center bar.

Where you can go from here:

- Move up or down to another preset station.
- Move left to return to the source selection screen.
- Move right to see the station tuning screen (Figure 11).

Figure 11

Example of a radio tuning screen

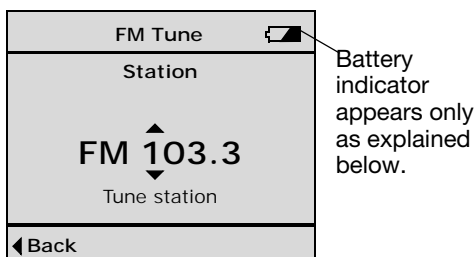

Or, press  to return to the list of the sources.

Display symbols

At times, you may notice that a symbol appears on the display. These symbols indicate special conditions, as described below:



Battery indicator: Your PERSONAL® music center II battery is depleted by 75% or more.



Speakers muted: The **Mute** button (on your RoomMate® speaker or your PERSONAL® music center II) has been pressed and the speakers in the room with your PERSONAL® music center II are silenced.



All speakers muted: The **Mute** button – on your PERSONAL® music center II or in another room – has been pressed and held, silencing the speakers in all Bose® link rooms. Pressing **Mute** now will unmute the speakers in your room only.



Information: Pressing the center bar  will provide further information about a track.

Setup button: use as needed

Pressing **Setup** presents a list of the adjustable features on your PERSONAL® music center II. Display characteristics are among them.

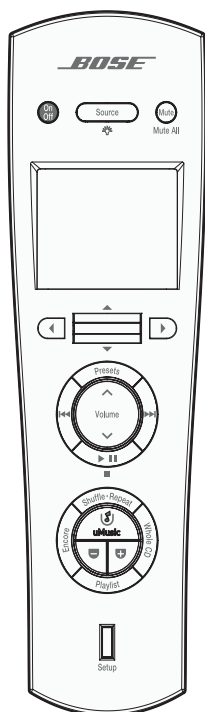

Buttons to use while you listen

There are two circular button sets for use while listening to a source. For details on how each button works for a specific source, refer to “Listening to Your LIFESTYLE® System” on page 21.

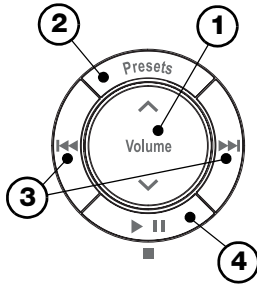

Use the upper button set to:

- ① Adjust the speaker volume up or down.
- ② Establish and select presets.
- ③ Skip and scan forward and back.
- ④ Begin or pause play.

Use the lower button set while listening to a music disc or stored music (if available on your system).

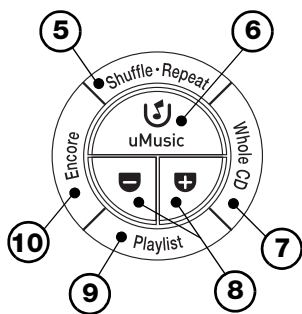

- ⑤ Each press of **Shuffle • Repeat** changes operation to the next play mode. Play modes include:

- Shuffle CD
- Repeat CD
- Shuffle and repeat CD
- Repeat track
- Normal

These modes apply to LIFESTYLE® system CD play; they may not apply to another Bose® system used as an Bose link room local source.

Use the remaining buttons in this circular set only with stored music, available on LIFESTYLE® 38 and 48 systems.

Use these buttons with your stored music to:

- ⑥ Select the uMusic™ playback system and turn on the LIFESTYLE® system if it is off.
- ⑦ Hear all other tracks from the CD that provided the current track.
- ⑧ Rate the track that is playing, or multiple tracks or CDs selected in the Music Library.
- ⑨ Hear the tracks that are included in the Playlist or add a selection to the Playlist.
- ⑩ Hear music that is similar in mood and style to the track that is playing.



Mutes and unmutes the speakers in the room where the PERSONAL® music center II is used.

When pressed and held, mutes all speakers connected to the LIFESTYLE® system.

When pressed and held again, returns all speakers to their previous state.

Adjustable features of the PERSONAL® music center II



Setup

You can change some factory default settings of the PERSONAL® music center II to customize it as you like.

Press the **Setup** button near the bottom of the PERSONAL® music center II to see a list of the feature settings you can change.

Note: To learn more about house codes, room codes, and audio streams, refer to the sections about these features.

To change settings for a feature

1. Tip the center bar down to move down the list in the Setup menu, and highlight the feature you want to adjust (Figure 12).
2. Press the right arrow button to move right for the setting options for the selected feature.
3. Tip the center bar up or down to move through the list and highlight the setting you want.
4. Press the center bar to confirm your choice.
5. Or, if you decide no change is needed, press the left arrow button instead.

Following step 4 or 5 will exit the list of options and return to the features list.

Figure 12

Music center II features that are adjustable

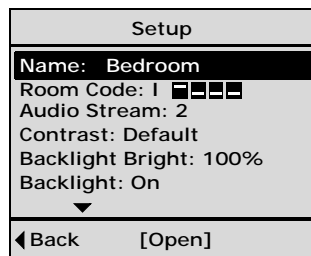

Feature	Possible settings
Name	Default: Bedroom. Designates where you use this PERSONAL® music center II. Choose from a list of possible rooms to label your music center and distinguish it from any others.
Room Code	Default: 1. Distinguishes each room (up to 15) connected to the system. Choosing A will match the setting for the LIFESTYLE® remote in the main room. Choosing O allows the PERSONAL® music center II to work with older (legacy) products, such as Bose® Acoustimass® 5 powered speakers, a Wave® radio, or other amplifiers, with limited functionality. For further information about room codes, refer to “The importance of room codes” on page 18.

Feature	Possible settings
Audio Stream	Default: 2. Delivers audio to the room where the PERSONAL® music center II is used and possibly to other rooms. For further information about audio streams, refer to “Audio streams multiply your options” on page 20.
Contrast	Default: Default. Visually distinguishes display text from background. Increase or reduce the display contrast as needed.
Backlight Bright	Default: 100%. Varies the amount of light on the display. Choose a lower % setting to reduce intensity.
Backlight	Default: On. Choose Off to eliminate backlighting.
LCD Delay	Default: 30 seconds. Increase or decrease (in 10-second increments) the pause before the setup display turns off.
House Code (Change ONLY under certain conditions.)	Default: 0. For further information about house codes, refer to “Why would you change the house code?” on page 19.
Language (Use ONLY when situation underlined at right occurs.)	Default: Update. Matches the display text to language selected for use on the LIFESTYLE® system. This match should occur automatically.* <i>*If it does not,</i> select this item to initiate a language download from the LIFESTYLE® system.
Version (not adjustable)	Indicates which version of the PERSONAL® music center II software is installed currently.

The importance of room codes

Your PERSONAL® music center II is set at the factory for use in a Bose® link room, while the LIFESTYLE® system media center and primary remote are set for use in the main room. The use of unique room codes lets your LIFESTYLE® system know where commands that come to it originate, so it can respond in the appropriate room.

With just your RoomMate® speaker system set up in one Bose® link room, the PERSONAL® music center should remain set to Room Code I, as shown (Figure 13).

Figure 13

Room Code I setting on the PERSONAL® music center II display



However, to use more than one PERSONAL® music center II, or with other LIFESTYLE® system remotes in your home, they all need to have different room codes.

When to change the room code

- If you have set up other Bose® link rooms already. There are 14 room codes in addition to Room A.
- If you prefer to use your PERSONAL® music center II in the main room, in addition to the primary remote control, it must be set for Room A.
- The PERSONAL® music center II and your RoomMate speaker must have identical room codes. Like the PERSONAL® music center II, the RoomMate speaker system is set at the factory for Room I. If you change this setting for any reason, you must also change the PERSONAL® music center II to the same room code.

To learn how to choose a different room code, see “To change settings for a feature” on page 17.

Note: For more room code details, refer to the operating guide that came with your LIFESTYLE® system.

Why would you change the house code?

Your PERSONAL® music center II is set at the factory with a house code identical to the factory setting on other LIFESTYLE® systems and remote controls. If you have not changed the house code setting in your LIFESTYLE® system, there is no need to change that code in your PERSONAL® music center II.

A LIFESTYLE® system radio frequency (RF) remote has a long range and the ability to penetrate walls. Therefore, the signals from a remote in one home can possibly reach and affect the operation of a LIFESTYLE® system in another. Changing the house code for the system and all the remotes used with it avoids possible conflict.

To learn how to choose a different house code, see “To change settings for a feature” on page 17.

Note: For more details on the system house code, refer to the operating guide included with your system.

Audio streams multiply your options

While the LIFESTYLE® system is playing in the main room, you can use your PERSONAL® music center II in another room to play a completely different choice from that same system.

The system provides this choice by employing two independent audio streams to deliver the sound. So, while the Audio 1 stream fills the main room with spine-tingling DVD special effects, you can move to another room and switch to FM radio on the other stream.



While the PERSONAL® music center II is set at the factory to control the Audio 2 stream, you can easily change it to Audio 1 – the stream that delivers sound in the main room.

For example, there may be times when you don't want to hear what is playing in one of your multiple Bose® link rooms. Without disturbing the person enjoying sound on the Audio 2 stream there, you can switch to Audio 1, which may not otherwise be in use. This option also allows people in different rooms to use the uMusic™ system with two different presets selected.

To learn how to choose a different audio stream, see “To change settings for a feature” on page 17.

LISTENING TO YOUR LIFESTYLE® SYSTEM

Performance at your command

By pressing , you turn on your PERSONAL® music center II to the last source selected on the selected audio stream. Select a different source by pressing  and moving up or down on the display to highlight the preferred source. Then press in on the center bar () to confirm your selection.

Use the buttons shown in Figure 14 as you listen. Your options will vary according to the source that is playing.

Figure 14

Buttons to use while listening to a source

- Press to **Select**
- Press and hold to **Set a preset**
- Press to **Seek backward** or **Play previous track**
- Press and hold to **Fast reverse**
- Press to **Seek forward** or **Play next track**
- Press and hold to **Fast forward**
- Press to **Play/Pause**
- Press and hold to **Stop**

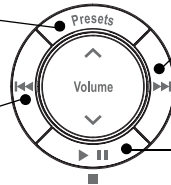

Playing stored music

To listen to your stored music, press the **uMusic™** system button on the PERSONAL® music center II. This turns on the LIFESTYLE® system, if it is off, and begins to play stored tracks.

Note: Use of the uMusic™ intelligent playback system is possible only on LIFESTYLE® 38 and 48 systems, and only after CDs are stored in the system. For details on how to store CDs, refer to your LIFESTYLE® system operating manual.

The display on your PERSONAL® music center II provides information about the music playing and the Stored music preset selected (Figure 15).

Figure 15

Stored music display

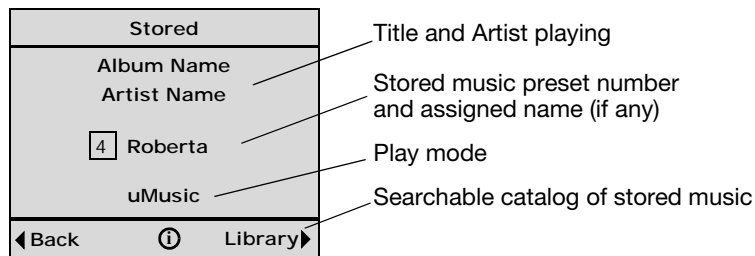



- Check to be sure that the uMusic system preset currently selected is the one you want. Presets, for use by different people or assigned for specific themes, help the system match its music selections to preferences associated with that preset.

Note: Refer to your LIFESTYLE® 38 or 48 system Operating Guide for detailed information on the uMusic intelligent playback system, the importance of presets, and how the system knows what to play.

LISTENING TO YOUR LIFESTYLE® SYSTEM

- To select a different preset:
 - Press the **Presets** button on the PERSONAL® music center.
 - Move up or down to highlight the preferred preset and press in on the center bar  to confirm the new selection.

This returns to the original display screen.

- To see more information on the current track:
Press in on the center bar  to select .
- To stop text from moving across the display:
Press in and hold the center bar . Press again to resume movement.
- To simply listen and enjoy:

No particular action is required. You may want to simply listen and respond to the music as you normally do. For this, use the circular *button sets* on the music center II.

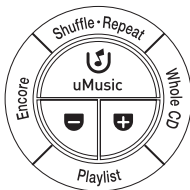
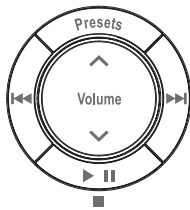
**In order to...**

Tell the system your strong reaction to a track...

Play more tracks like the one playing now...

Play the whole CD that this track came from...

Play the tracks in the Playlist...

Delete this track from the Playlist...

Add this track to the Playlist...

Let the system pick the tracks for you...

Hear this track again...

Hear the music playing in a different order...

Pause the music...

Resume play where the music paused...

Do this...

Press the minus (–) button if you are not in the mood for or do not like this song.

Press the plus (+) button if you especially like this song.

Press **Encore**.

Press **Whole CD**.

Press **Playlist**.

While listening to the Playlist, press and hold **Playlist**.

While listening to a track in uMusic, Encore or Whole CD play modes, but *not* in the Playlist, press and hold **Playlist**.

Press **uMusic** to exit the Encore, Whole CD, or Playlist play mode.

Press **Repeat**.

Press **Shuffle** while in Whole CD, Playlist, or Encore play mode. Otherwise, it has no effect.

Press **▶ ||**.

Press **▶ ||**.

In order to...

Scan forward through the current track...

Scan backward through the current track...

Skip to the beginning of this track...

Skip to the beginning of the previous track...

Skip this track...

Return to a previous track...

See the list of other sources...

Do this...

Press and hold **▶▶**.

Press and hold **◀◀**.

Press **◀◀**.

Or, tip down on the center bar .

Press **◀◀** twice.

Or, tip down on center bar  twice.

Tip up on the center bar .

Tip up and hold to skip more tracks.

Tip down on the center bar .

Tip down and hold to skip more tracks.

Press the left arrow button  to move left.

Or, press .

Searching the library of stored music

You may want to locate other tracks in your collection, which is easy to do using the display on your PERSONAL® music center II.

While listening to the Stored source, press the right arrow button to see the library search screen (Figure 16):

Figure 16

Music Library display

**To search and use what you find**

1. Move up or down to highlight the category you want to use to search the library. The categories are:
 - Genre: one of 19 music types that describe stored tracks.
 - Artist: the primary performer or group
 - Album: name of the disc
 - Track: title of the track



- Press in on the center bar  to see the possible choices in that category (Figure 17).

Figure 17

Results of the search for artists in all genres



- Move up or down to make a selection.
- Press in on the center bar  to confirm the selection and return to the category list.
 - Or, move right to play your selection and continue browsing the choices for this category.
 - Or, move left to cancel the selection.
- Move down the categories and repeat steps 2 through 4 to further narrow your search.
- Move right to play all tracks in the selected category.
- When you finish searching, you can move left to return to the Stored music display.

Using the radio

To listen to the radio, select AM or FM from your list of sources. The LIFESTYLE® system activates, as needed, and begins play.

The display on your PERSONAL® music center II provides information about the radio station and preset (Figure 18).

Figure 18

Station information display



While listening to a station, you have several options.

In order to...



Do this...

Tune to a specific station...

Move right for FM tuning, then up or down to the station you want.

Tune to the next or previous preset...

Tip up on the center bar .
Tip up and hold to tune more quickly.

<i>In order to...</i>	<i>Do this...</i>
Tune to higher or lower frequencies...	Move right into station tuning, then tip up or down on the center bar  . Tip and hold to tune more quickly.
Choose a specific preset...	Press the Presets button. Or, tip up or down on the center bar  to select the next preset.
Tune forward to the next strong station...	Press ▶▶ . Press and hold to tune quickly and release to stop at the next station.
Tune backward to the next strong station...	Press ◀◀ . Press and hold to tune quickly and release to stop at the next station.

Using radio presets



Your LIFESTYLE® system can store up to 20 AM and 20 FM stations as radio presets. By assigning a preset number to the stations you like most, you can get to them quickly and easily. All of the presets can be used in any of the Bose link rooms.

To assign preset numbers

Most simply, you can let the system assign the next available preset number to the station you have tuned in.

- Press and hold the **Presets** button until a preset number appears on the display next to the station identity.

Or, assign a specific preset number to a station by following steps 1 through 5:

1. Press the **Presets** button to see the list of established presets for FM or AM.
2. Move up or down to highlight the preset you prefer.
3. Move right to select that preset number.
4. Tip up or down on the center bar  to tune in the station you want assigned to the selected preset number.
5. Press in on the center bar  to confirm the assignment.

Playing a CD

Make sure there is a CD in the disc tray. The player can then begin to play as soon as you select CD/DVD from the source list.

The display on your PERSONAL® music center II provides information about the disc and track playing. The display indicates whether the disc is a regular or MP3 CD (Figure 19).

Figure 19

CD and MP3 CD displays



- Move up or down to change tracks one by one.
- Press in on and hold the center bar  to see the numeric selection display, where you can choose the track directly by number (Figure 20).

Figure 20

Numeric selection display





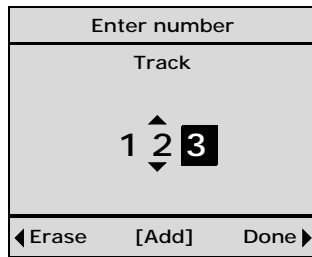



To select a specific track by number

When the numeric selection display appears:

- Move up or down to increase or decrease the highlighted number.
- Press in on the center bar  to confirm the digit and add another.
- Move left to erase a number.
- Move right when you have set the number as you want it.

Or, simply listen and use the PERSONAL® music center II buttons to choose from the full range of control options.

<i>In order to...</i>	<i>Do this...</i>
Pause the music...	Press ► .
Resume play from where the music paused...	Press ► .
Stop and start again at the beginning of the CD...	Press and hold ► . Then press again.
Scan forward through the current track...	Press and hold ►►.
Scan backward through the current track...	Press and hold ◀◀.
Skip to the next track...	Press ►► once. Or, tip up on the center bar  .
Skip to the beginning of the current track...	Press ◀◀ once.
Skip to the beginning of the previous track...	Press ◀◀ twice. Or, tip down on the center bar  .
Skip quickly forward...	Tip up on the center bar  and hold.
Skip quickly backward...	Tip down on the center bar  and hold.
Select a track by number...	Press in on the center bar  Move up or down to change to the first digit of the track number. Press in to confirm the number and move on to the next digit, etc.
See the list of other sources...	Press the left arrow button  to move left.

Playing a DVD or VCD

With a DVD or VCD loaded in the disc tray of the LIFESTYLE® system in your main room, select CD/DVD from your list of sources. This turns on the player, if it is off, and begins video play.

The display on your PERSONAL® music center II provides information about the DVD and indicates whether the disc is a DVD or a VCD (Figure 21).

LISTENING TO YOUR LIFESTYLE® SYSTEM

Figure 21

DVD or VCD display

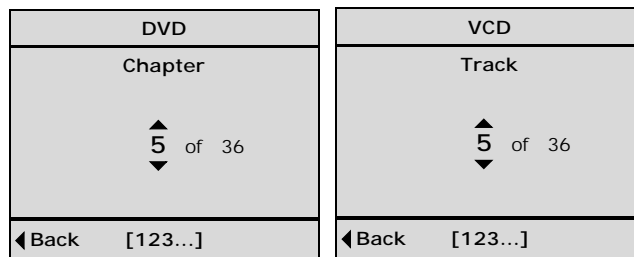

- You can move up or down to change chapters (or tracks) one by one, or press the center bar  to see the screen that allows you to select a chapter (track) by number.
- Or, just listen and use the PERSONAL® music center II buttons to choose from the following control options.

In order to...

Begin play...

Pause the sound...

Resume sound at the point of advanced action...

Stop and start again at the beginning of the DVD...

Skip to the next chapter (track)...

Skip to the beginning of the previous chapter (track)...









Scan forward...
(silences temporarily)Scan backward...
(silences temporarily)

Select a chapter (track) by number...

See the list of other sources...

Do this...Press  . Repeat as needed.

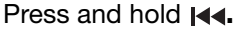
Note: DVDs vary in their content presentation. After pressing Play the first time, you may see a menu of multiple options. Before the main attraction begins to play, you may need to press Play a second or even a third time.

Press  .Press  .Press and hold  .
Then press again.Tip up on the center bar .
Tip and hold to skip more than one.Tip down on the center bar .
Tip and hold to skip more chapters.Press .
Press repeatedly to increase speed.Press and hold .
Press repeatedly to increase speed.Press and hold the center bar .
Then move up or down to change a number and press the center bar to confirm.Press the left arrow button  to move left.

Listening to other sources

Your LIFESTYLE® system has connection jacks for other components, like a TV, VCR, and cable or satellite box, and can select and operate the additional source connected using these jacks.

Each one of these components also appears in the source list of your PERSONAL® music center II. So, once a component in the list has been turned on, you can select and listen to it.

🎵 **Note:** Except for a TV, the PERSONAL® music center II will not turn components connected to your LIFESTYLE® system on or off.

- For a video component, use the up and down arrows  on your PERSONAL® music center II to change channels.

Or use numeric entry as described on page 26. You can enter up to 5 digits.

- For other components, you may also be able to seek, pause, and resume play as you can for a CD or DVD playing on the system. However, this depends on the type and brand of the connected equipment.

Listening to Your Local Source

The device connected to the AUX IN jack on your RoomMate® speaker is identified as a Local source in the list of sources on your PERSONAL® music center II display.

🎵 **Note:** "Local" is not an available selection when your PERSONAL® music center II is set for use in Room A.

To listen to your local source:



1. Press **Source** to see the list of sources.
2. Move up or down to highlight **Local** and press in on the center bar  to confirm the selection.

This turns on your RoomMate speaker to the volume, play medium (radio, CD, etc.), and pre-set (if that applies) last selected.

The PERSONAL® music center II display (Figure 22) offers a generic guide to the actions you can take.

Figure 22

Generic display for the moves you can make

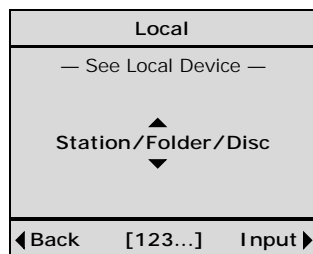

- Move up or down to scroll through local selections.
- Move right to change inputs (for audio on your local source, or connected to it).

CARE AND MAINTENANCE

Troubleshooting

Problem	What to do
Your PERSONAL® music center II doesn't work as expected	<ul style="list-style-type: none"> • It could be time to change batteries. • In some buildings, you may experience “dead spots” when the PERSONAL® music center II will not operate effectively. If this happens, simply move it a foot or two and try again. • Make sure the cord that connects the power supply to the LIFESTYLE® system media center (which contains the remote antenna) is vertically oriented, stretched to its full length, and separated from other power cords. • Try moving the LIFESTYLE® media center a few feet to see if this provides a better response. • You may need an antenna extender, which is described in the LIFESTYLE® system installation guide.
No sound	<ul style="list-style-type: none"> • Make sure the RoomMate® speaker is plugged in and the Bose® link cable is connected. • Make sure you select a source on the PERSONAL® music center II. • Increase the system volume. • Press Mute on the PERSONAL® music center II. • Touch the mute switch on the RoomMate® speaker. • Make sure the house code setting for the PERSONAL® music center II matches the house code in the primary remote. <i>Unless you changed it, the house code setting in both should be 0.</i> • Make sure the PERSONAL® music center II room code setting matches the RoomMate speaker room code setting.
Intermittent response from the LIFESTYLE® system to commands from the PERSONAL® music center II	<ul style="list-style-type: none"> • It could be time to change batteries. • Move the PERSONAL® music center II to see if the problem is caused by “dead spots” in the building. • You may need an antenna extender, which is described in the LIFESTYLE® installation guide.
Your system turns on or off unexpectedly or other tuning changes occur when no buttons on the PERSONAL® music center II have been pressed	<ul style="list-style-type: none"> • Check to see if someone in the main room is using the primary remote and is experiencing the same problem. If not, you may be experiencing a control conflict with another nearby LIFESTYLE® system. Changing the house code may solve the problem. • Refer to your LIFESTYLE® operating guide for details on when and how to change the house code.
Audio 1 stream doesn't work	<ul style="list-style-type: none"> • If you are using an older Bose product, which is not Bose link compatible, you may be limited to the Audio 2 stream only.
Cannot hear my external source	<ul style="list-style-type: none"> • Make sure cable from the external device is connected to the AUX IN jack. • Make sure the external device is turned on. • Turn up the volume on the external device.

Cleaning

To clean your RoomMate® powered speaker or PERSONAL® music center II, wipe the enclosure using a soft dry cloth. You can also lightly vacuum the grille on the speaker.

- DO NOT use solvents, chemicals, or sprays.
- DO NOT allow liquids to spill or objects to drop into any openings.

Contacting customer service

For additional help in solving problems, contact Bose® Customer Service. See the address and phone number list included with your LIFESTYLE® system.

Limited warranty

Your RoomMate® powered speaker and PERSONAL® music center II are covered by a transferable limited warranty. See your product registration card for details. Please be sure to fill out the information section on the card and mail it to Bose. Failure to do so will not affect your limited warranty.

Technical information

RoomMate® powered speaker

Size

6.65" H x 11.91" W x 4.68" D
(16.89 cm x 30.26 cm x 11.88 cm)

Weight

4.45 lb (2.02 kg)

Power rating

100-240V \sim 50-60Hz, 1.5A-0.8A, 64-77VA

PERSONAL® music center II

Remote control range

80 ft (24.4 m)

Size

8¼" L x 1" H x 2½" W
(21 cm x 3 cm x 6 cm)

Weight with batteries installed

0.7 lb (.3 kg)

Battery type

1.5V AA (IEC LR6) batteries (4)

Frequency

U.S./Canada: 27.145 MHz
Euro: 40.685 MHz

RF Field Strength

Peak level: 88 dB μ V/m @ 3 meters



285143

BOSE[®]
Better sound through research[®]

©2005 Bose Corporation, The Mountain,
Framingham, MA 01701-9168 USA
285143 AM Rev.00 CCM-001671