

# VGIC gas 36" wide sealed burner range – dimensions

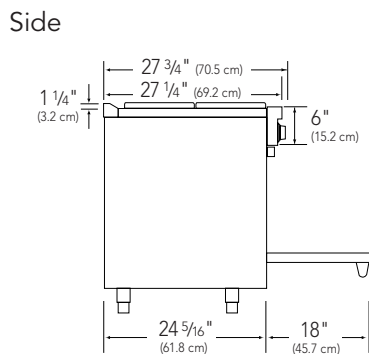

With island trim

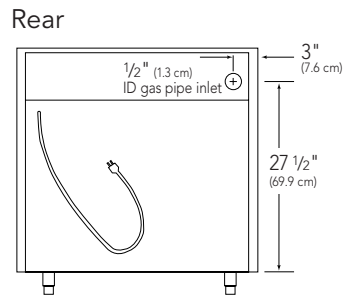
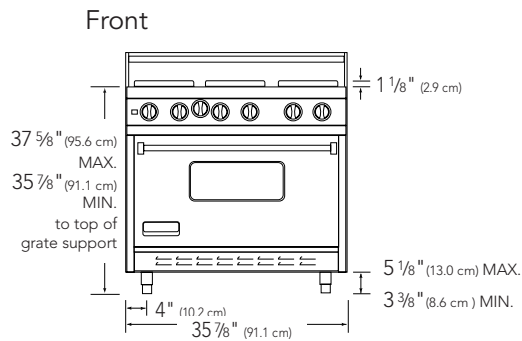
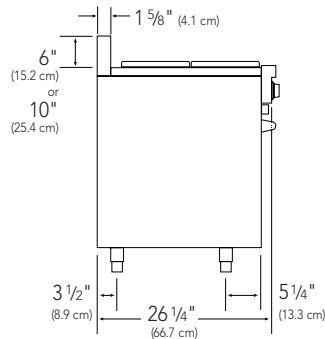

With backguard

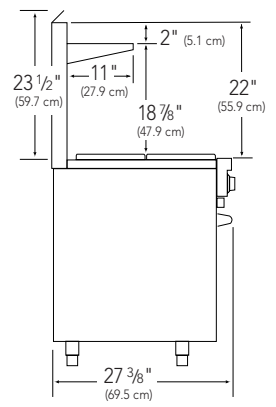

With high-shelf

## Adjustable legs

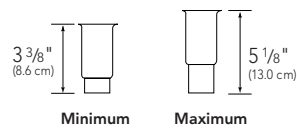

## Surface burners

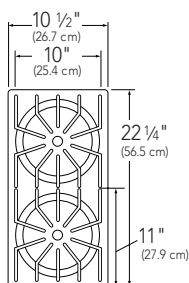

## Grill

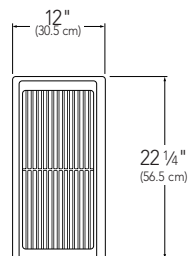

## Griddle/simmer plate

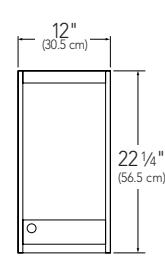

## Notes

A properly grounded, adequately powered, horizontally mounted electrical receptacle should be installed no higher than 3" (7.6 cm) above the floor and not less than 6" (15.2 cm) from the right side (facing product). Check all local code requirements.

An agency-approved, properly sized manual shut-off valve should be installed no higher than 3" (7.6 cm) above the floor and not less than 6" (15.2 cm) from the left side (facing product). To connect gas between shut-off valve and regulator, use agency-approved, properly sized flexible conduit or rigid pipe. Check all local code requirements.

## Basic specifications

Description	36" WIDE GAS SEALED BURNER RANGE
	VGIC367
<b>Overall Width</b>	35 7/8" (91.1 cm)
<b>Overall Height from Bottom</b>	<p><b>Base Height</b> To top of grate support – min. 35 7/8" (91.1 cm) to max. 37 5/8" (95.6 cm); legs adjust 1 3/4" (4.5 cm)</p> <p><b>Additions to Base Height</b> To top of spider grate – add 1 1/8" (2.9 cm), to top of island trim – add 1 1/4" (3.2 cm), to top of 6"H. backguard – add 6" (15.2 cm), to top of high-shelf – add 23 1/2" (59.7 cm)</p>
<b>Overall Depth from Rear</b>	To end of side panel – 24 5/16" (61.8 cm), to end of control panel – 26 1/4" (66.7 cm), to end of knobs – 27 3/4" (70.5 cm)
<b>Gas Requirements</b>	Shipped natural gas standard; field convert to LP/Propane with standard convertible regulator; accepts standard residential 1/2" (1.3 cm) ID gas service line
<b>Electrical Requirements</b>	120VAC/60Hz; 4 ft. (121.9 cm), 3-wire cord with grounded 3-prong plug attached to product
<b>Maximum Amp Usage</b>	6B – 8.1 amps 4G – 11.4 amps 4Q – 8.1 amps
<b>Surface Burner Rating</b>	15,000 BTU NAT./13,500 BTU LP (4.4 kW NAT./4.0 kW LP)
<b>Griddle Burner Rating</b>	15,000 BTU NAT./13,500 BTU LP (4.4 kW NAT./4.0 kW LP)
<b>Grill Burner Rating</b>	18,000 BTU NAT./16,000 BTU LP (5.3 kW NAT./4.7 kW LP)
<b>Broil Burner Rating</b>	<p><b>Infrared</b> 18,000 BTU NAT./16,000 BTU LP (5.3 kW NAT./4.7 kW LP)</p>
<b>Bake Burner Rating</b>	Two 15,000 BTU ea. NAT./LP (Two 4.4 kW ea. NAT./LP)
<b>Oven Interior Dimensions</b>	<p><b>Convection Bake/Broil Oven</b> Width – 30 1/8" (76.5 cm) Height – 16 1/8" (41.0 cm) Depth – 17 5/8" (44.8 cm) Overall Size – 5.0 cu. ft. Three racks, six rack positions</p>
<b>Approximate Shipping Weight</b>	6B – 415 lb. (186.8 kg) 4G – 425 lb. (191.3 kg) 4Q – 420 lb. (189.0 kg)