



Fisher & Paykel
innovative living

kitchen appliances



OUR HERITAGE



The Fisher & Paykel story began in 1934. Maurice Paykel and Sir Woolf Fisher were innovators who wanted to improve people's lives through technology.

For nearly 70 years, Fisher & Paykel have been developing appliances and manufacturing techniques that have revolutionized the appliance industry.

Today the company manufactures refrigerators, freezers, washing machines, dryers, dishwashers, ovens and cooktops at plants in New Zealand and Australia. Fisher & Paykel is headquartered in New Zealand, with offices in Australia, USA, Singapore, Hong Kong, Taiwan, and the United Kingdom.

Generations have trusted Fisher & Paykel to add value to their lives. We aim to continue that vision for generations to come.

The kitchen is the heart of any home, the place where we come together and entertain, as a family or with friends. The atmosphere we create in our kitchen sets the stage for times of important connection with those closest to us.

With this in mind, Fisher & Paykel designs elegant kitchen appliances with supreme functionality.

Great cuisine relies on the finest ingredients and the right tools. Fisher & Paykel offers the essential cooking equipment with the perfect blend of function and sophisticated style.

Fisher & Paykel does not stop at giving you exciting cooking tools. With our DishDrawer® dishwasher clean up is as enjoyable as cooking. But be careful, your visitors may worship it, more than your culinary triumphs.

Every appliance is designed to exude the core values of Fisher & Paykel – style, care, innovation and integrity.

So, whether you are preparing a light brunch for family or entertaining a house-full, Fisher & Paykel appliances let you rediscover the romance of entertaining.



AEROTECH™

The AeroTech™ oven is the synthesis between lifestyle, design and technology. The fusion of easy-to-use controls, precise electronics and elegant design create the dream oven; fulfilling your desire for performance and beauty.

Our unique system takes true convection a step further. We have designed the fan shroud and the spiral intake in such a way that it distributes hot air evenly throughout the oven in a way that is exclusive to AeroTech™. Using a micro-processor, AeroTech™ is the only 30" oven able to offer such accurate temperatures.

The large cavity provides 3.5 cubic feet of usable space, illuminated by three full sized halogen floodlights. The Optilevel® shelving system, a robust dual-wire shelf with 13 positions, provides the ultimate in cooking flexibility.

With 10 cooking modes, precise electronic temperature control and abundant interior space you will have the power to compose a symphony of culinary delights.

Whether you prefer European or standard installation, your kitchen will benefit from the quality Fisher & Paykel has built into AeroTech™, from TrueAero enhanced convection, right down to the durability of the satin chrome control knobs.



AeroTech™ OVEN FEATURES

PERFORMANCE

- ▶ AeroTech™ True Convection distributes air more evenly through the oven for even cooking and browning
- ▶ 10 Cooking Functions
- ▶ Temperature is precisely controlled using a microprocessor
- ▶ Multi-shelf cooking
- ▶ 12 pass Maxi-broil element
- ▶ 10 pass broil element
- ▶ 4,400 W total broil power
- ▶ Closed-door broiling
- ▶ Proofing capabilities
- ▶ Fast pre-heat
- ▶ Active venting system removes smoke, odor and oils using a catalytic converter and an additional fan
- ▶ Unique throat element improves self-cleaning performance
- ▶ Dual gasket sealing system
- ▶ Separate airflows on the double oven stop any odor and flavor transfer

USABILITY

- ▶ Large 3.5 cu. ft. of usable space /4 cu. ft. total space
- ▶ Optilevel™ 13 shelf positions
- ▶ Pyrolytic self-cleaning
- ▶ Three full-sized white halogen interior lights for ultimate visibility
- ▶ Concealed heating elements (with recessed broil element)
- ▶ Sabbath mode
- ▶ Under counter or wall mount installation options
- ▶ European or traditional installation options
- ▶ Diamond blue, acid resistant porcelain interior
- ▶ Delayed timed cooking
- ▶ Child safety lock
- ▶ Large viewing window
- ▶ Easy to use analog controls provide instant visual feedback
- ▶ Counter balanced door hinges
- ▶ Quiet Operation - 46.2 dB on Bake, 46.8 dB on TrueAero)
- ▶ Self diagnostics for servicing
- ▶ Complete 2 year parts and labor warranty

Accessory Package Included:

	OS301 Single Oven	OD301 Double Oven
Dual Wire Shelves	3	6
Non-Stick Cookie Sheets	2	4
Cooking Probe	1	2
3 Piece Anti-Splatter Broil System	1	2
Oven to Table Glass Baking Tray	1	1
Pizza Stone	1	1
Pizza Paddle	1	1
Unique Cooking Guide	1	1

COOKING MODES



TrueAero

Using the combination of the fan and the back element, hot air is distributed evenly throughout the oven cavity. As surround sound has enhanced stereo performance, TrueAero has enhanced convection cooking. AeroTech™ enhances convection airflows.

The even temperature created through TrueAero creates an ideal environment for multi-shelf cooking: perfect for casseroles, re-heating oven meals and baking multiple trays of cookies.

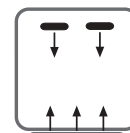

Bake

Heat comes from the top outer heating element and the lower concealed element. Bake is the conventional cooking mode, suitable for single shelf cooking. Use Bake to cook all your favorite conventional recipes; foods that require long cooking periods or cooking at low temperatures like meringues and rich fruitcakes.



AeroPastry

Uses heat from the lower concealed element, which is then circulated throughout the oven cavity by the fan. Use not only for sweet and savory pastry foods but also for moist breads and brownies and for cookies that you want extra chewy.

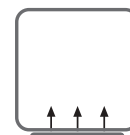

Pastry Bake

Using heat from the lower element only, this traditional cooking mode is suitable for recipes developed in older ovens. Preheat first on bake or AeroBake to save time. As with other non-aero modes, cook only one shelf at a time.

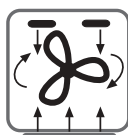

AeroBake

The fan circulates hot air from the top outer and lower concealed elements and distributes it around the oven cavity. Food cooked using the AeroBake mode tends to brown more quickly than foods cooked on non-aero modes like Bake or Pastry Bake. AeroBakes great for crisping pastry. Use AeroBake at a low temperature (100°F) for drying fruit, vegetables and herbs.

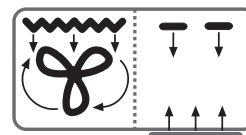

Roast

With no pre-heat time required, this automatic roasting mode sears roasts at a high temperature giving a crisp, brown exterior. The oven automatically reduces to your preset temperature for the remainder of the cooking time, ensuring your roast remains moist.

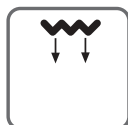

Broil

Using intense heat from the inner 10-pass top element, this is the most suitable mode for quickly broiling smaller amounts of your usual favorites. Broil requires no pre-heating and is carried out with the oven door closed.

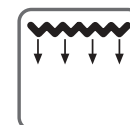

Maxi Broil

Using intense heat from the entire 12-pass top element, maxi broil is the most suitable mode for "finishing off" many meals; for example browning the top of potato gratin or cooking smaller cuts of meat. Broil requires no pre-heating and is carried out with the oven door closed.



AeroBroil

AeroBroil produces food with a finish similar to a rotisserie. Meat, poultry and vegetables cook beautifully: food is crisp and brown on the outside with the inside remaining moist and tender. Use this mode with foods you might usually fry, like meatballs.

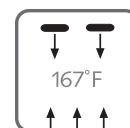

Warm

Using a constant low heat, this mode is useful for keeping food warm or warming plates.



36" GAS AND ELECTRIC COOKTOPS

Cooking is as much an art as it is a science. Our cooktops deliver both disciplines in equal measure.

Fisher & Paykel 36" cooktops are an elegant solution for the busy kitchen, giving you a large and flexible cooking surface. Each cooktop incorporates five burners and a continuous surface to accommodate multiple tasks needed for one meal. The heavy commercial stainless steel surface ensures years of satisfaction and durability.

The unique design of our cooktops, with their shallow cutout depths, provide more usable space in the kitchen allowing you to install an oven directly underneath. Each cooktop offers a sealed cooking surface with a large spill area.

So, whether you prefer to cook with gas or on a precisely controlled electric cooktop, Fisher & Paykel has an elegant solution for you.

Each of our gas cooktops offer:

- ▶ Continuous cooking surface
- ▶ Sealed cooking surface
- ▶ Electronic Auto Re-ignition
- ▶ Graphics are permanent and laser etched
- ▶ LPG conversion kit
- ▶ High altitude kit available
- ▶ Ventilation recommendation = 450 CFM

Accessory Package Included:

(Retail Value \$135.00)

- ▶ Griddle plate
- ▶ Simmer plate
- ▶ Spatula (heat tested to 400°F)

COOKTOP FEATURES



GC901

GC901 GAS COOKTOP

- ▶ Reversible wok grate
- ▶ 1 gallon spill surface
- ▶ 500 BTU simmer burner
- ▶ Height above countertop only 5/8"

GC901 BTU Burner Outputs	Natural Gas	LPG
Triple Ring Rapid Burner	14,000 – 3,400	13,000 – 3,400
Rapid Burner	2 at 8,400 – 2,000	2 at 8,700 – 2,000
Semi Rapid Burner	5,800 – 1,200	5,700 – 1,200
Simmer Burner	3,000 – 500	3,000 – 500

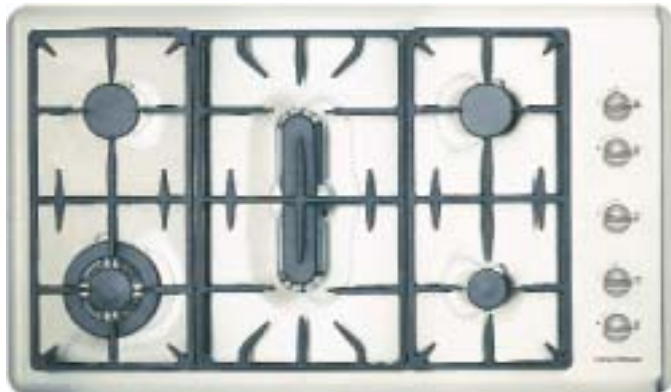

GC36

GC36 GAS COOKTOP

- ▶ Unique Griddle Burner
- ▶ 0.66 gallon spill surface
- ▶ Control knobs in satin chrome or black
- ▶ Height above countertop 2"

GC36 BTU Burner Outputs	Natural Gas	LPG
Triple Ring Rapid Burner	13,000 – 3,400	13,000 – 3,400
Griddle Burner	9,500 – 2,300	9,500 – 2,300
Semi Rapid Burner	2 at 8,000 – 1,200	2 at 8,000 – 1,200
Simmer Burner	3,500 – 900	3,500 – 900



CE901

CE901 ELECTRIC COOKTOP

- ▶ Optimal control with lower turndown temperatures
- ▶ 1/2 gallon spill surface
- ▶ Unique Hot light/On light element status indicators provide instant visual feedback from across the room
- ▶ Ceran glass
- ▶ Graphics are permanent and laser etched
- ▶ Height above countertop 5/8"

CE901 Burner Outputs	Maximum	Minimum
Dual Burner	2.5 kW	125 Watts
Inner of Dual	1.1 kW	55 Watts
2 Large Burners	1.8 kW	90 Watts
2 Medium Burners	1.2 kW	60 Watts

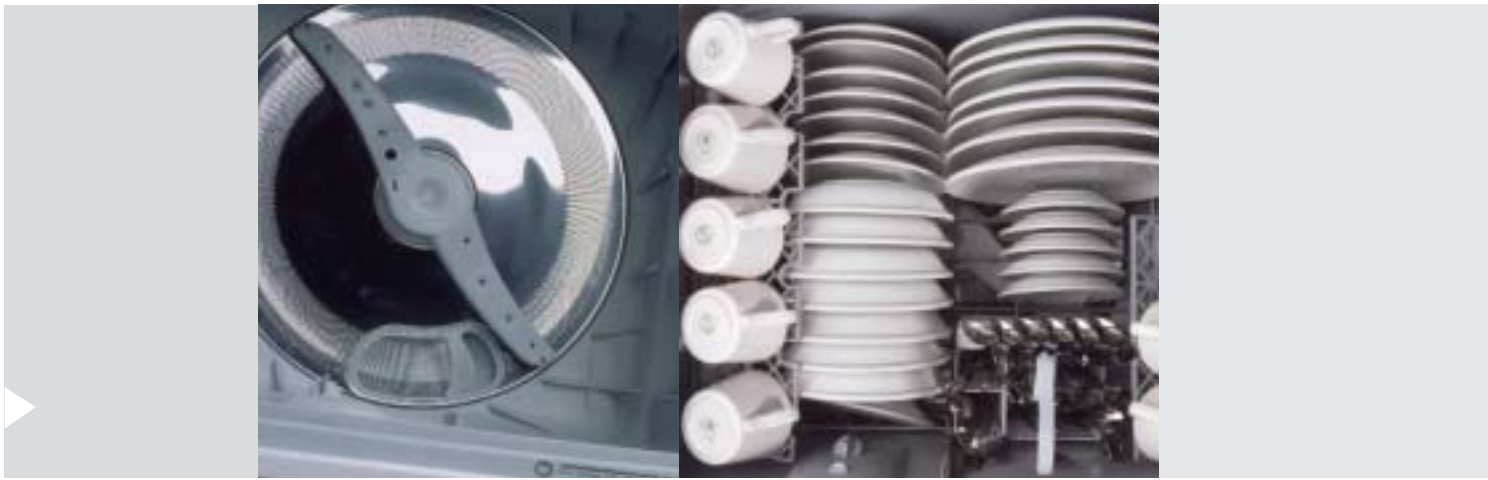

DISHDRAWER® DISHWASHER

Clean up with our elegantly sleek DishDrawer®. DishDrawer® consists of two completely independent dishwashers. You can put delicate crystal in one drawer, and heavily soiled pots in the other, then simply customize the wash in each drawer.

The DishDrawer® is an ergonomically designed dishwasher, incorporating the familiar kitchen drawer concept into dishwashing. Each drawer requires fewer movements to open, load and close, making clean-up a breeze.

DishDrawer® provides the ultimate in design flexibility without compromise. Imagine DishDrawer® by your side wherever you are working in the kitchen, like a single drawer in the island to handle preparation dishes. Imagine a single drawer on either side of the sink to eliminate all bending required to use your dishwasher. You can even have the panels match your cabinetry for a completely integrated look in your kitchen.

DishDrawer® is the only dishwasher that uses variable water pressures and a flow-through detergent dispenser with precise wash temperatures to deliver a superior wash. With the use of electronics DishDrawer® is able to perform more complex tasks more efficiently, while being easier to use.

With DishDrawer® you have a dishwasher that fits your kitchen as well as your lifestyle.



DISHDRAWER® FEATURES

PERFORMANCE

- ▶ The only dishwasher in drawers
- ▶ Single unit offers ultimate design flexibility
- ▶ Double drawer unit offers two dishwashers in one
- ▶ Each drawer works independently
 - ▶ Gently bath stemware in one drawer while the other drawer power-scrubs pans
- ▶ Superior wash by using variable water pressures
- ▶ Flow-through detergent dispenser
- ▶ Precise wash temperatures
- ▶ 9 wash programs
- ▶ Rinse agent dispenser
- ▶ Increased reliability with no belts, pulleys, or clutches. Parts that aren't there can't fail.
- ▶ 163°F sanitizing temperatures
- ▶ Minimized water, energy and detergent consumption
- ▶ Eco option saves time and energy
- ▶ Each drawer has a heating element
- ▶ ENERGYSTAR approved - double drawer unit



USABILITY

- ▶ Superior ergonomics reducing bending
- ▶ Concealed wash cycle controls
- ▶ Delay start up to 12 hours in one hour increments
- ▶ Unique motor technology washes very quietly
- ▶ Digital display shows time remaining for the cycle and the segment of the cycle that is currently being performed (pre-finished models only)
- ▶ End of cycle beeps
- ▶ Holds plates up to 11 5/8"
- ▶ Insert available to wash 12" dinner plates
- ▶ Each drawer holds 7 sets of dinner plates, dessert plates, soup bowls, saucers, cups and 7 sets of cutlery
- ▶ Interchangeable racks
- ▶ Special rack to wash stemware included
- ▶ Child lock
- ▶ Key lock
- ▶ Self diagnostics for servicing
- ▶ Extensive 2-year parts and labor warranty
- ▶ Available in Black, White, Stainless Steel or attach your own integrated panels



Black
DD603B



Stainless Steel
DD603SS

DD603HSS
(with water softener)



White
DD603W



Integrated
DD603I

DD603HI
(with water softener)

The integrated panel and handle are not provided with the DishDrawer® dishwashing system



Black
DS603B



Stainless Steel
DS603SS

DS603HSS
(with water softener)



White
DS603W



Integrated
DS603I

DS603HI
(with water softener)

The integrated panel and handle are not provided with the DishDrawer® dishwashing system

DISHDRAWER® AND CABINETY DIMENSIONS

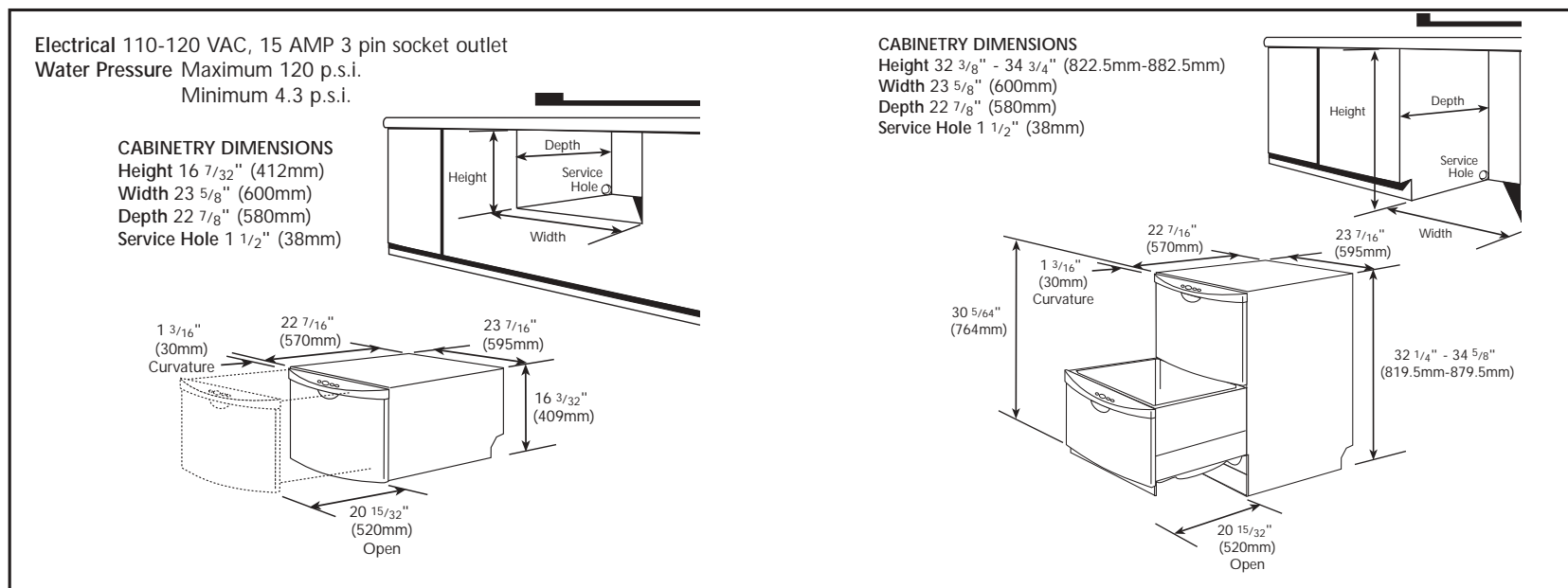

COOKTOP AND CABINETY DIMENSIONS

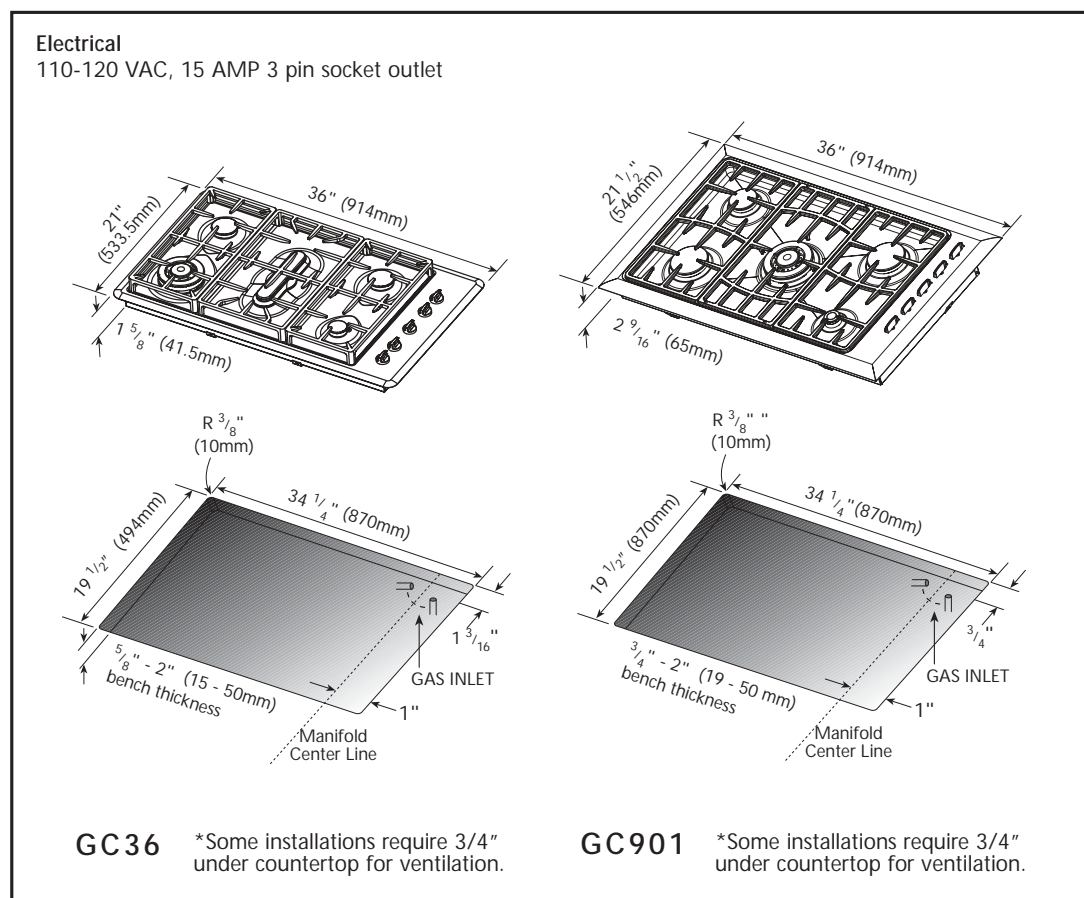
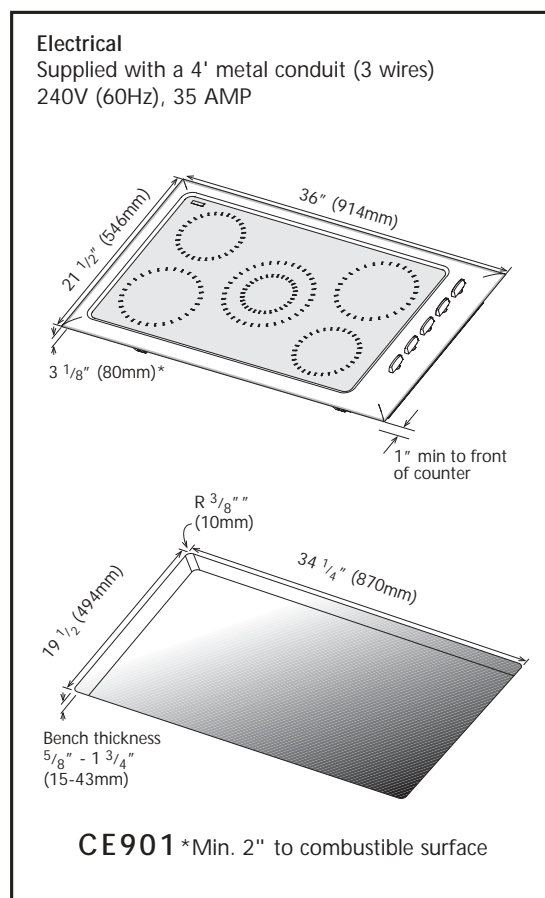

Please Note: Product dimensions differ from cutout dimensions



OVEN AND CABINETS DIMENSIONS

Electrical
240V, 38.2 AMP Double, 21 AMP Single

SINGLE OVEN OS301

DOUBLE OVEN OD301

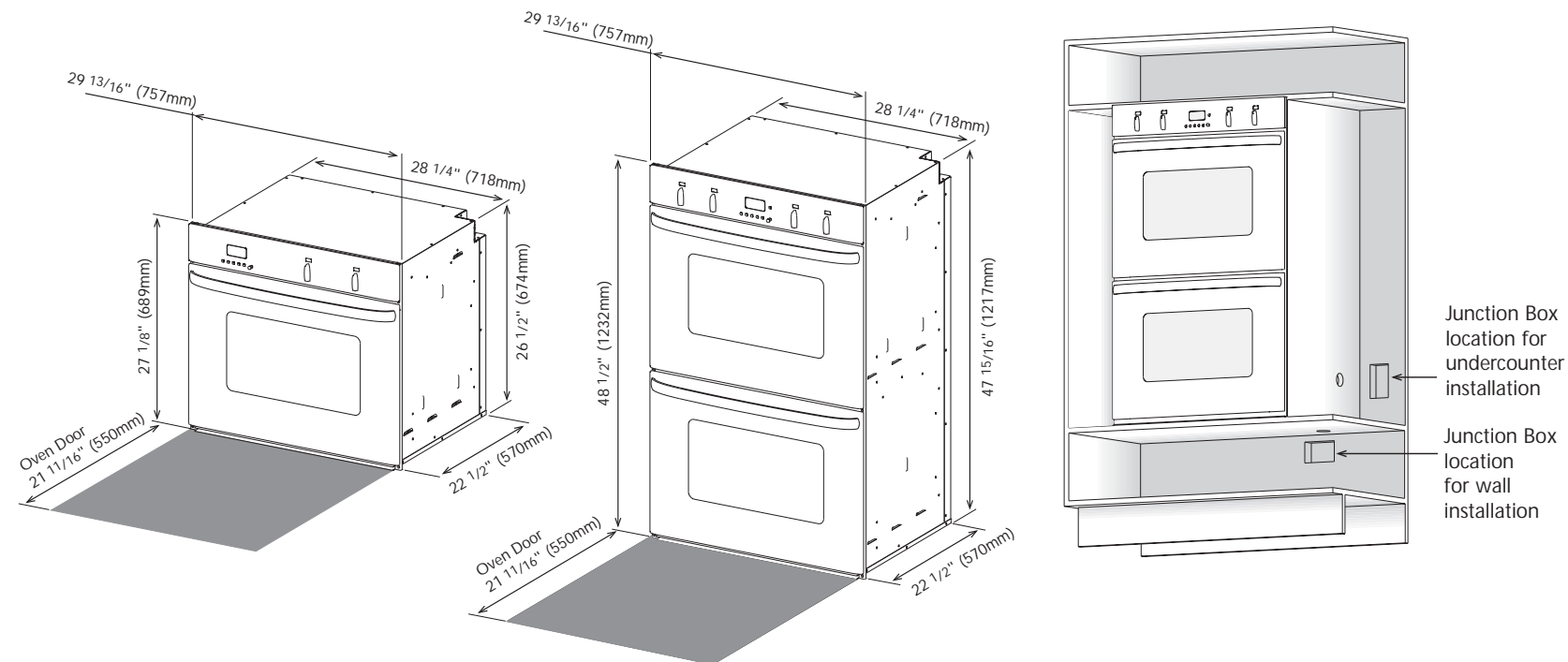

STANDARD INSTALLATION

EUROPEAN INSTALLATION

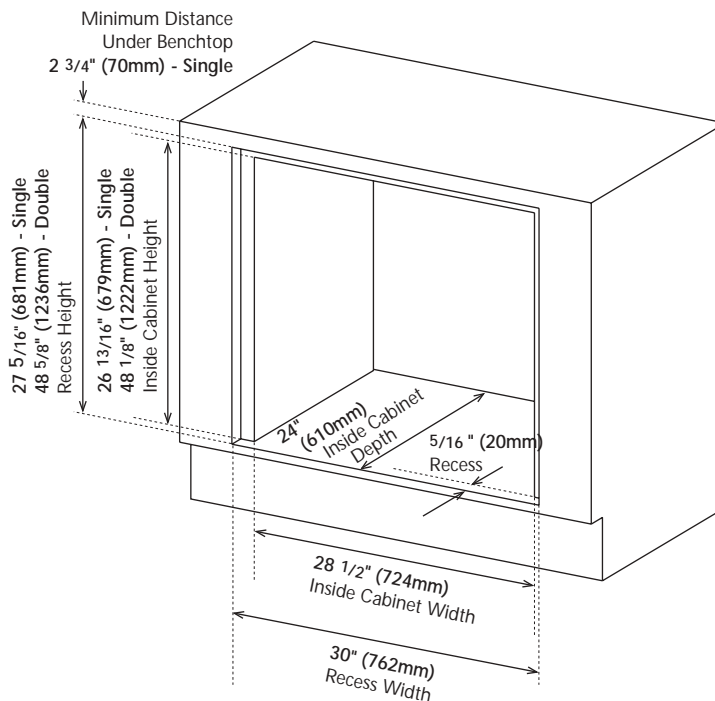
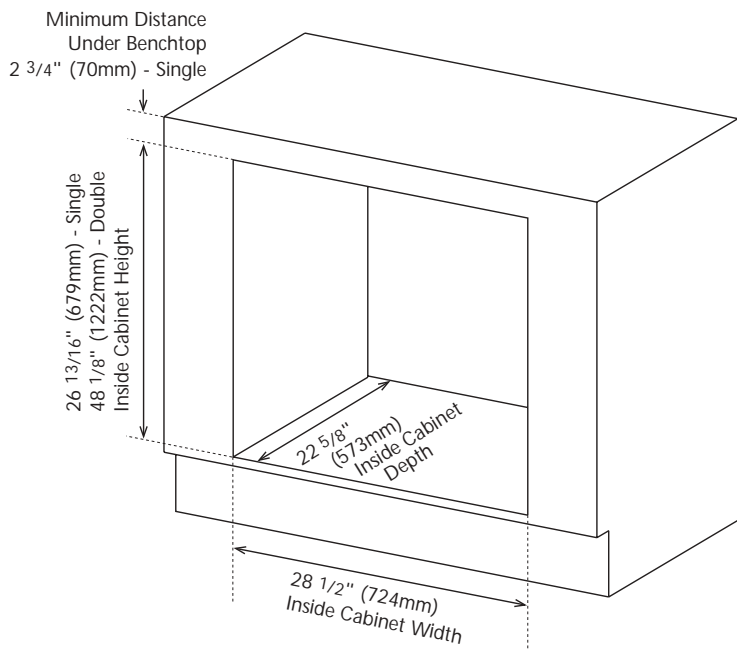
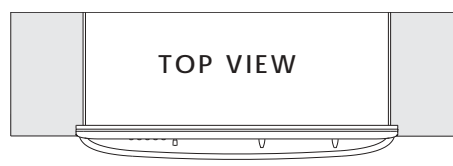
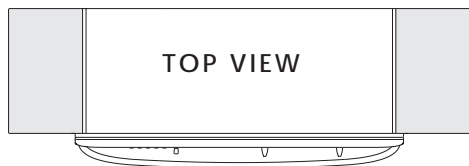

Copyright Reserved © Fisher & Paykel 2002

The product specifications in the booklet apply to the specific products and models described at the date of issue. Under our policy of continuous product improvement, these specifications may change at any time. You should therefore check with your Dealer to ensure this booklet correctly describes the product available.

All Fisher & Paykel product come with a complete 2 year parts and labor warranty.



FISHER & PAYKEL APPLIANCES INC., 27 HUBBLE, IRVINE, CA 92618, USA PHONE 1800 863 5394