

Thank you for selecting a YAMAHA speaker system.

PRECAUTIONS

Read these precautions carefully before using your speakers.

- To assure the finest performance, please read this manual carefully. Keep it in a safe place for future reference.
- Install the speaker in a cool, dry, clean place - away from windows, heat sources, sources of excessive vibration, dust, moisture and cold. Avoid sources of humming (transformers, motors). To prevent fire or electrical shock, do not expose the speaker to rain or water.
- To prevent the enclosure from warping or discoloring, do not place the speaker where it will be exposed to direct sunlight or excessive humidity.
- Do not place the following objects on the speaker: Glass, china, etc.

If glass etc. falls by vibrations and breaks, it may cause bodily injury.

A burning candle etc.

If the candle falls by vibrations, it may cause fire and bodily injury.

A vessel with water in it

If the vessel falls by vibrations and water spills, it may cause damage to the speaker, and/or you may get an electric shock.

- Do not place the speaker where foreign objects such as water drips might fall. It might cause a fire, damage to the speaker, and/or bodily injury.
- Do not place the speaker where it is liable to be knocked over or struck by falling objects. Stable placement will also ensure better sound performance.
- Placing the speaker on the same shelf or rack as the turntable can result in feedback.
- Never put a hand or a foreign object into the port located on the rear of the speaker as this might cause bodily injury and/or damage to the speaker.
- When moving the speaker, do not hold the port as it might cause bodily injury and/or damage to the speaker.
- Any time you note distortion, reduce the volume control on your amplifier to a lower setting. Never allow your amplifier to be driven into "clipping". Otherwise the speaker may be damaged.
- When using an amplifier with a rated output power higher than the nominal input power of the speaker, care should be taken never to exceed the speaker's maximum input.
- Do not attempt to clean the speaker with chemical solvents as this might damage the finish. Use a clean, dry cloth.

- Do not attempt to modify or fix the speaker. Contact qualified YAMAHA service personnel when any service is needed. The cabinet should never be opened for any reasons.
- **Secure placement or installation is the owner's responsibility. YAMAHA shall not be liable for any accident caused by improper placement or installation of speaker.**

PRECAUTIONS WHEN POSITIONING THE SPEAKERS

The speaker is constructed with the majority of the weight located in its upper portion, and is thus susceptible to falling over if proper care is not taken to insure its stability. If the speaker falls over, it may damage the speaker or be the cause of injury (or even death) to persons and/or damage to personal property.

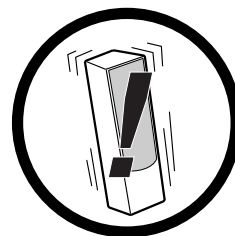

For safe and proper use of the speaker:

- Position the speaker in a location that is solid, level, smooth, and low (with respect to the floor).
- Do not push or apply pressure to the side of the speaker when moving, or lean objects against the side of the speaker.
- Do not sit on or set objects on top of the speaker.

Vibrations or jolts associated with earthquakes and other phenomena or activities may cause the speaker to fall over.

For safety reasons, using commercially available products that increase stability in the speaker is recommended (metal fittings or chains, etc.).

Use the stands included with the speaker to increase stability:

Be sure to use the stands regardless of where the speaker is positioned. Attaching the stands included with the speaker reinforces the base of the speaker not to fall over.

Please be cautioned that even though the stands are connected, this does not guarantee that the speaker will not fall over.

ATTACHING THE STANDS

When placing the speakers, be sure to use the stands to increase stability.

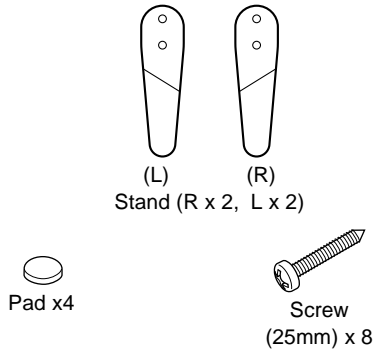

Note

The provided stands are in two types. Two stands are for the right side and others are for the left side. Attach each stand to the proper position on the bottom of the speaker by following the figure below.

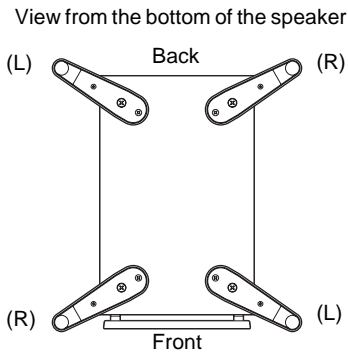

Use the 8 specified holes located on the base of the speaker.

Procedure:

- Put a screw through the inner hole on the stand, and screw it into the speaker at one of the outside holes on the base of the speaker. At this time, screw it untightly so that the stand can still be moved.

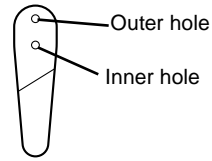

- Put a screw through the outer hole on the stand, and screw it into the other hole on the base of the speaker.
- Tighten both of the screws firmly.
- Attach a pad to the bottom of the end portion of the stand.
- Attach the other stands to the other corners of the base of the speaker in the same way and confirm that all 4 stands have been firmly attached.

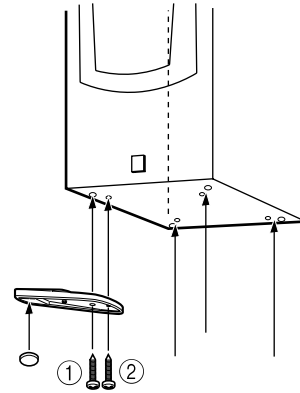

Note

Be carefull not to apply force to the side of the speaker, otherwise the speaker may fall causing damage to the speaker or personal injury.

CONNECTIONS TO YOUR AMPLIFIER

This speaker system is capable of standard connections and bi-wired connections. Before making connections, make sure that the amplifier is switched off.

[Standard Connection]

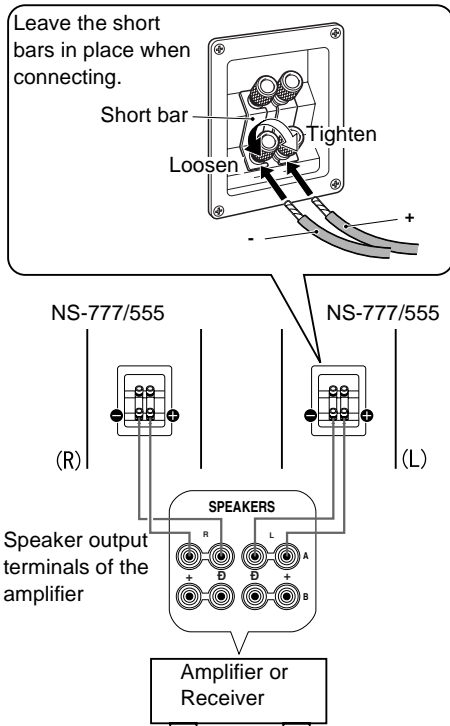

■ CONNECTIONS

- Connect the screw-type input terminals at the rear of the speaker to the speaker output terminals of the amplifier (or receiver) with the speaker cable.
- Connect the (+) terminals on the amplifier (or receiver) and the speaker using one side of the cable. Connect the (-) terminals on both components using the other side of the cable.
- Connect one speaker to the left (marked L) terminals of your amplifier, and another speaker to the right (marked R) terminals, making sure not to reverse the polarity (+, -). If one speaker is connected with reversed polarity, the sound will be unnatural and lack bass.

How to Connect:

- ① Remove the insulation coating at the extremity of each speaker cable by twisting the coating off.

Good **No Good**

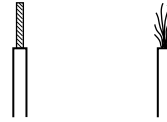

- ② Loosen the terminal knob.
- ③ Insert the bare wire.
- ④ Tighten the knob and secure the cable. Test the firmness of the connection by pulling lightly on the cable at the terminal.

Note

Do not let the bare speaker wires touch each other as this could damage the speaker or the amplifier, or both of them.

Using a Banana Plug

Banana Plug

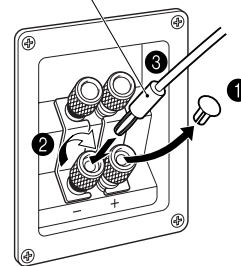

- ① Remove the cover by pulling it toward you.
- ② Tighten the terminal knob.
- ③ Simply insert the banana plug into the terminal.

[Bi-Wired Connection]

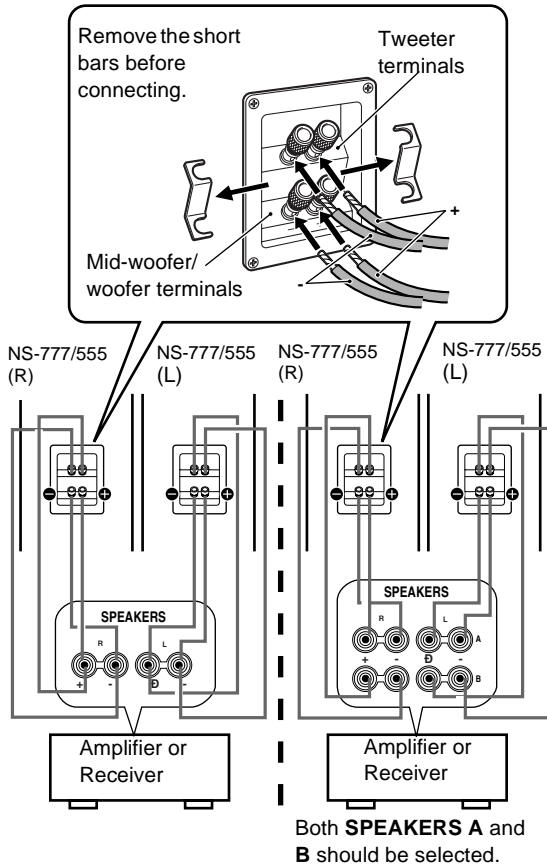

This speaker system is capable of bi-wired connections. To connect the speaker to the output terminals of the amplifier (or receiver), two pairs of cables for each of mid-woofer/woofer and tweeter used instead of standard connections.

This type of connection decreases the modulation distortion caused by electric resistance of the cables and driving current of the speakers. Consequently, purer sound quality can be expected.

To utilize bi-wired connections, remove the short bars from the terminals first, and then connect the mid-woofer/woofer and tweeter to the amplifier separately using two pairs of cables.

PLACING THE SPEAKERS

Place the speakers on a sturdy, vibration-free surface, on a well-built stand.

■ Using as 2ch stereo speakers

Better stereo images will be obtained when the speakers are slightly angled in towards the listeners.

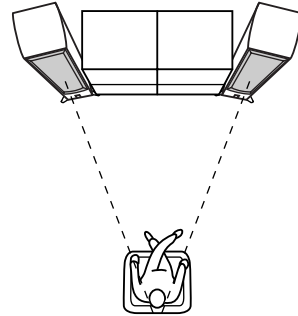

■ Using as main speakers in a multi channel system

Position the speakers on both sides of the TV. The positioning of speakers is important, because it controls the whole sound quality of a multi channel system. Set up the speakers on the basis of your listening position by following the owner's manual supplied with your amplifier.

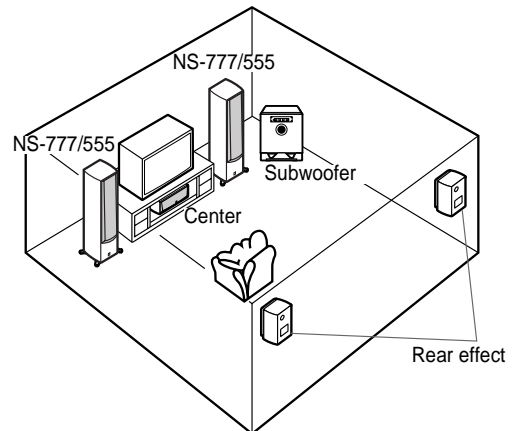

Note

This speaker features a magnetically shielded design, but there is still a chance that placing it too close to a TV set might impair picture color. Should this happen, move the speaker away from the TV set.

REMOVING THE FRONT COVER

The front cover is fastened to the enclosure at six points and can be removed if desired. To remove the cover, hold on to both sides and slowly pull straight away from the speaker. To reattach, line up the six pegs on the inside surface of the cover with the six corresponding holes on the speaker and push gently.

NS-777

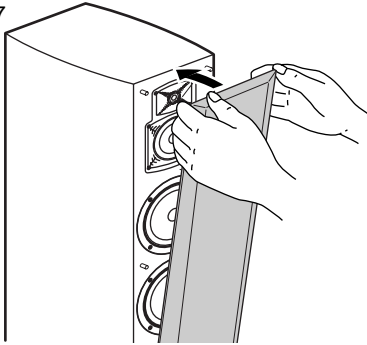

NS-555

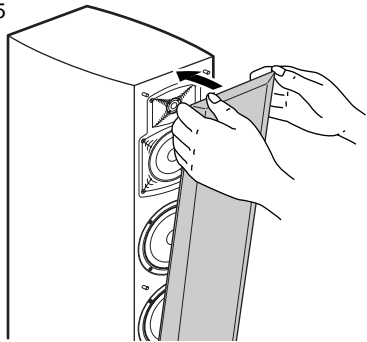

Note

When the cover is removed, take care not to touch the speaker units with your hands or to exert excessive force with tools.

SPECIFICATIONS

NS-777

Type	3-way bass reflex speaker system
	Magnetic shielding type
Driver	20 cm (8") cone woofer x 2
	Wave guide horn 13 cm (5") cone mid-range
	Wave guide horn 2.5 cm (1") dome tweeter
Frequency response	30 Hz – 35 kHz
Nominal impedance	6 ohms
Nominal input power	100 W
Maximum input power	250 W
Sensitivity	89 dB/2.83 V/m
Crossover frequency	1 kHz, 4kHz
Dimensions (W x H x D)	
	276 mm x 1100 mm x 390 mm
	(10.9"x 43.3" x 15.4")
Weight	24 kg (52.9 lbs)
Accessories	Stand x 4
	Screw x 8
	Pad x 4

NS-555

Type	3-way bass reflex speaker system
	Magnetic shielding type
Driver	16 cm (6.5") cone woofer x 2
	Wave guide horn 13 cm (5") cone mid-range
	Wave guide horn 2.5 cm (1") dome tweeter
Frequency response	35 Hz – 35 kHz
Nominal impedance	6 ohms
Nominal input power	100 W
Maximum input power	250 W
Sensitivity	89 dB/2.83 V/m
Crossover frequency	1 kHz, 4kHz
Dimensions (W x H x D) ...	222 mm x 980 mm x 345 mm
	(8.74"x 38.6" x 13.6")
Weight	20 kg (44.1 lbs)
Accessories	Stand x 4
	Screw x 8
	Pad x 4

- Specifications subject to change without notice due to product improvements.
- Care should be taken not to exceed the input power values noted above.