

The Bose® Companion® 3 Multimedia Speaker System

Owner's Guide

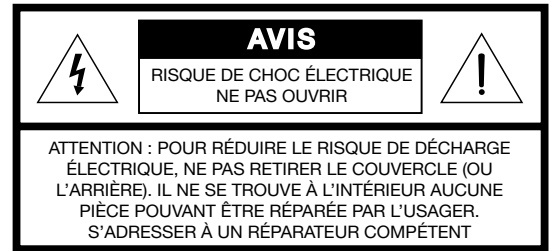

WARNING: To reduce the risk of fire or electric shock, do not expose this system to rain or moisture. The apparatus shall not be exposed to dripping or splashing, and objects filled with liquids, such as vases, shall not be placed on the apparatus.

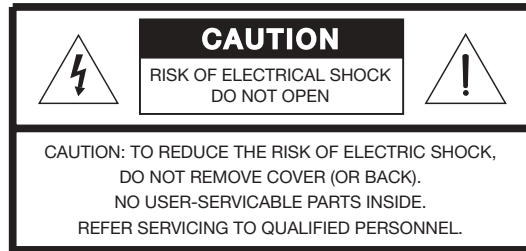

These CAUTION marks are located on the rear panel of the Acoustimass® module:



The lightning flash with arrowhead symbol, within an equilateral triangle, is intended to alert the user to the presence of uninsulated dangerous voltage within the system enclosure that may be of sufficient magnitude to constitute a risk of electric shock.



The exclamation point, within an equilateral triangle, as marked on the system, is intended to alert the user to the presence of important operating and maintenance instruction in this owner's guide.

CAUTION: To prevent electric shock, match wide blade of plug to wide slot, insert fully.

Please read this owner's guide

Please take the time to read and follow this owner's guide carefully. It will help you set up and operate your system properly, and enjoy all of its advanced features. Save your owner's guide for future reference.

CAUTION: Do not place computer monitors, floppy disks, hard drives, or other magnetic media within 6 inches of the Acoustimass module. The magnetic field produced by this module can erase magnetic media and interfere with the monitor.

1. **Read these instructions** – for all components before using this product.
2. **Keep these instructions** – for future reference.
3. **Heed all warnings** – on the product and in the owner's guide.
4. **Follow all instructions.**
5. **Do not use this apparatus near water or moisture** – Do not use this product near a bathtub, washbowl, kitchen sink, laundry tub, in a wet basement, near a swimming pool, or anywhere else that water or moisture are present.
6. **Clean only with a dry cloth** – and as directed by Bose® Corporation. Unplug this product from the wall outlet before cleaning.
7. **Do not block any ventilation openings. Install in accordance with the manufacturer's instructions** – To ensure reliable operation of the product and to protect it from overheating, put the product in a position and location that will not interfere with its proper ventilation. For example, do not place the product on a bed, sofa, or similar surface that may block the ventilation openings. Do not put it in a built-in system, such as a bookcase or a cabinet that may keep air from flowing through its ventilation openings.
8. **Do not install near any heat sources, such as radiators, heat registers, stoves or other apparatus (including amplifiers) that produce heat.**
9. **Do not defeat the safety purpose of the polarized or grounding-type plug. A polarized plug has two blades with one wider than the other. A grounding-type plug has two blades and a third grounding prong. The wider blade or third prong are provided for your safety. If the provided plug does not fit in your outlet, consult an electrician for replacement of the obsolete outlet.**
10. **Protect the power cord from being walked on or pinched, particularly at plugs, convenience receptacles, and the point where they exit from the apparatus.**
11. **Only use attachments/accessories specified by the manufacturer.**
12. **Use only with the cart, stand, tripod, bracket or table specified by the manufacturer or sold with the apparatus. When a cart is used, use caution when moving the cart/apparatus combination to avoid injury from tip-over.**
13. **Unplug this apparatus during lightning storms or when unused for long periods of time** – to prevent damage to this product.
14. **Refer all servicing to qualified service personnel. Servicing is required when the apparatus has been damaged in any way: such as power-supply cord or plug is damaged; liquid has been spilled or objects have fallen into the apparatus; the apparatus has been exposed to rain or moisture, does not operate normally, or has been dropped** – Do not attempt to service this product yourself. Opening or removing covers may expose you to dangerous voltages or other hazards. Please call Bose to be referred to an authorized service center near you.
15. **To prevent risk of fire or electric shock, avoid overloading wall outlets, extension cords, or integral convenience receptacles.**
16. **Do not let objects or liquids enter the product** – as they may touch dangerous voltage points or short-out parts that could result in a fire or electric shock.
17. **See product enclosure bottom for safety related markings.**



Information about products that generate electrical noise

If applicable, this equipment has been tested and found to comply with the limits for a Class B digital device, pursuant to Part 15 of the FCC rules. These limits are designed to provide reasonable protection against harmful interference in a residential installation. This equipment generates, uses, and can radiate radio frequency energy and, if not installed and used in accordance with the instructions, may cause harmful interference to radio communications. However, this is no guarantee that interference will not occur in a particular installation. If this equipment does cause harmful interference to radio or television reception, which can be determined by turning the equipment off and on, you are encouraged to try to correct the interference by one or more of the following measures:

- Reorient or relocate the receiving antenna.
- Increase the separation between the equipment and receiver.
- Connect the equipment to an outlet on a different circuit than the one to which the receiver is connected.
- Consult the dealer or an experienced radio/TV technician for help.

Note: *Unauthorized modification of the receiver or radio remote control could void the user's authority to operate this equipment.*

This product complies with the Canadian ICES-003 Class B specifications.

Important Safety Instructions

18. **Use Proper Power Sources** – Plug the product into a proper power source, as described in the operating instructions or as marked on the product.
19. **Avoid Power Lines** – Use extreme care when installing an outside antenna system to keep from touching power lines or circuits, as contact with them may be fatal. Do not install external antennas near overhead power lines or other electric light or power circuits, nor where an antenna can fall into such circuits or power lines.
20. **Ground All Outdoor Antennas** – If an external antenna or cable system is connected to this product, be sure the antenna or cable system is grounded. This will provide some protection against voltage surges and built-up static charges.

Section 810 of the National Electrical Code ANSI/NFPA No. 70 provides information with respect to proper grounding of the mast and supporting structure, grounding of the lead-in wire to an antenna discharge unit, size of grounding conductors, location of antenna-discharge unit, connection to grounding electrodes, and requirements for the ground electrode. Refer to the antenna grounding illustration on this page.

Antenna grounding

Example of antenna grounding as per National Electrical Code, ANSI/NFPA 70.

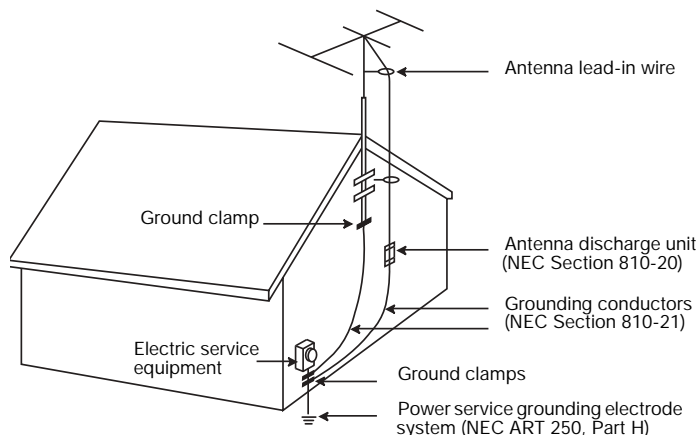

Note to CATV system installer

This reminder is provided to call the CATV system installer's attention to Article 820-40 of the NEC (of USA) that provides guidelines for proper grounding. In particular, it specifies that the cable ground shall be connected to the grounding system of the building, as close to the point of cable entry as is practical.

Your Companion® 3 multimedia speaker system	4
Unpacking	5
Selecting a location for your Companion 3 multimedia speaker system	6
Positioning the Acoustimass® module	6
Positioning the satellite speakers	7
If placing your speakers on the desktop	7
If mounting speakers on your monitor	7
Making connections	9
To connect	9
To make the final connection and power the system	9
Additional Connections	9
To connect an additional sound source	9
To connect headphones	9
Operating the Companion 3 multimedia speaker system	10
Turning your speaker system on and off	10
Adjusting the sound	10
Bass	10
Volume	10
Troubleshooting	11
Maintaining the Companion 3 multimedia speaker system	12
Cleaning the system	12
Warranty period	12
Technical Information	12
Features	12
Driver complement	12
Power rating	12
Dimensions	12
Weight	12
Finish	12

For your records

Serial numbers are located on the back of the Acoustimass module.

Serial number: _____ and _____

Dealer name: _____

Dealer phone: _____

We suggest you keep your sales slip together with this owner's guide.

 **Note:** Now would be a good time to register your product online at www.bose.com/register.

Your Companion® 3 Multimedia Speaker System

Thank you for purchasing the Bose® Companion 3 multimedia speaker system. Bose designed this amplified speaker system to provide high-fidelity stereo sound for your computer and a variety of other desktop sources. Its unique features make this system a superior choice for your home or office workspaces.

- Small satellite speakers and an Acoustimass® module that hides away helps maximize workspace.
- Magnetically-shielded satellite speakers protect your screen from color distortion so you can place satellite speakers right next to your monitor or television.
- TrueSpace® stereo signal processing provides a wide soundstage even when the speakers are close together.
- Tethered control pod allows you to control system volume and connect headphones or portable players.
- Integrated signal processing provides full, rich sound at all listening levels.
- Auxiliary input jack lets you expand your system to include an external source such as a CD player, MP3 player, or other audio source.

Unpacking

Carefully unpack your system. Save all packing materials, which provide the safest way to transport your system as needed.

WARNING: To avoid danger of suffocation, keep the plastic bags out of the reach of children.

If any part of the system appears damaged, do not attempt to use it. Notify Bose Corporation or your authorized Bose® dealer immediately. For contact information, refer to the address sheet included in the carton.

Check to be sure your system includes the parts shown in Figure 1.

Note: Now is a good time to find the serial number on the back of the Acoustimass® module. Copy that number in the space provided under “For your records” on page 3.

Figure 1

Contents of the shipping carton

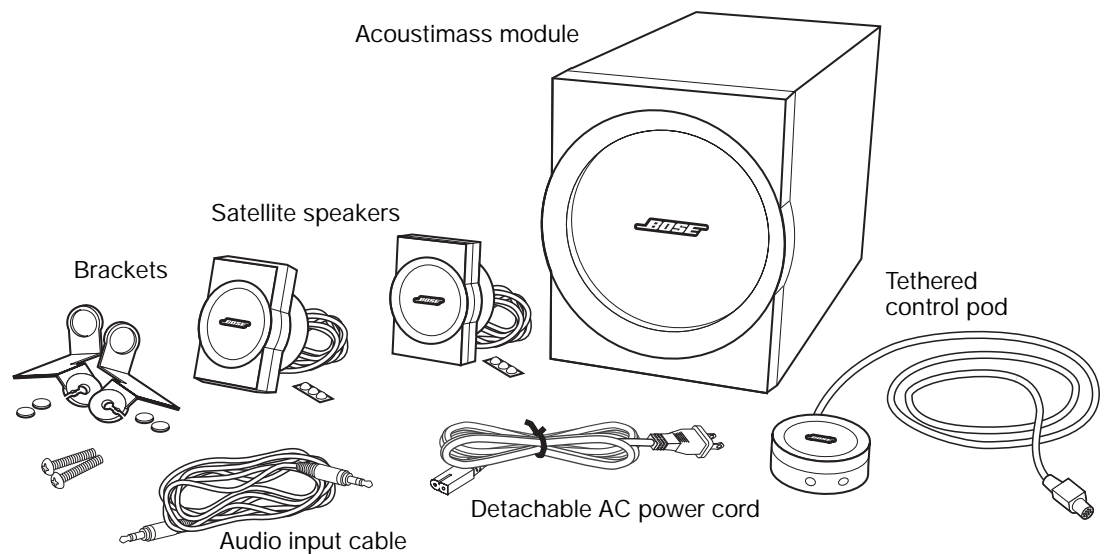

Selecting a location for your Companion® 3 Multimedia Speaker System

Use the following guidelines to choose locations and positions for the speakers and the Acoustimass® module (Figure 2). While these guidelines are offered to provide outstanding system performance, you may find other placement options that are more convenient and provide the sound you enjoy.

Figure 2

Recommended system placement

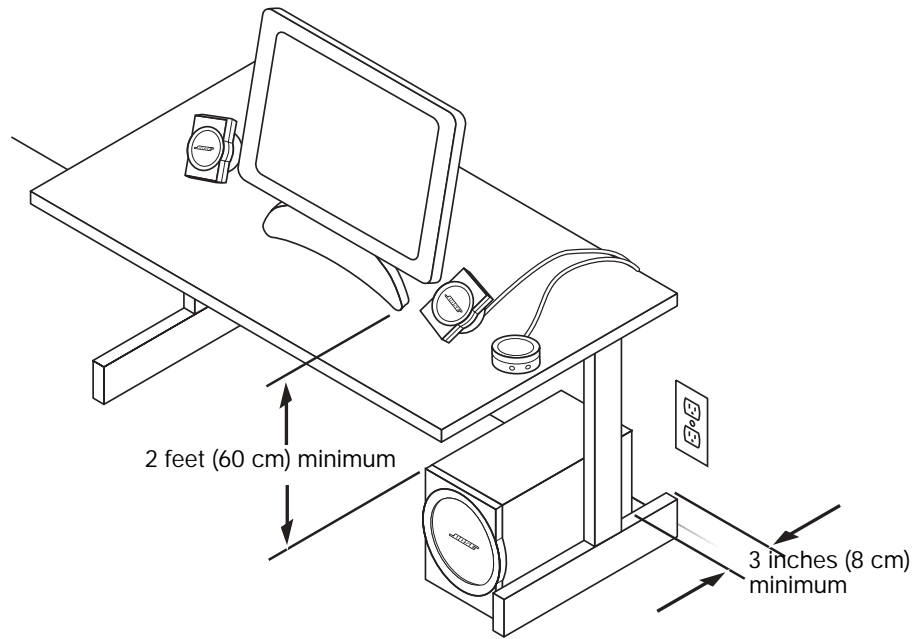

Positioning the Acoustimass module

The Acoustimass module is designed to be the unseen part of this system. It can be placed under or behind furniture, for example, and contribute to the lifelike sound you hear from the speakers without being visible.

Place the module on a flat surface:

- within reach of an AC (mains) power outlet and
- place the module a minimum of 2 feet (.60 m) from the computer monitor (or TV) to prevent interference from the module, which is not magnetically shielded.

CAUTION: Do not place computer monitors, floppy disks, hard drives, or other magnetic media within 6 inches (15 cm) of the Acoustimass module. The magnetic field produced by this module can erase magnetic media and interfere with the monitor.

- Stand the Acoustimass module on its feet. Do not lay it on its side or stand it on either end (Figure 3).

Figure 3

Module placement

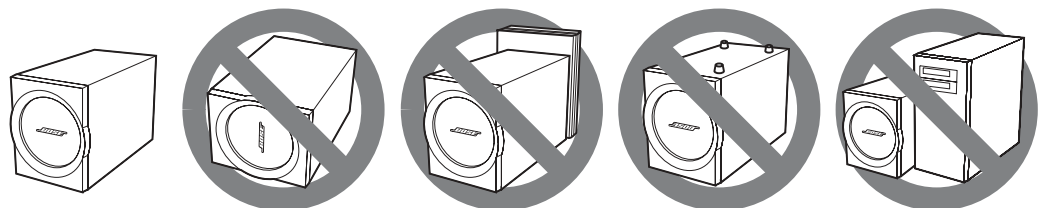

- Aim the port of the module away from the wall to decrease bass or toward the wall to increase bass; in either case, be sure it is at least 3 inches (8 cm) from the wall.
- Place the module away from heat sources (radiators, baseboard, quartz heater, etc.). Adequate ventilation is necessary to prevent the module from overheating during use. Do not block the openings on the back of the module, which provide ventilation for the built-in circuitry.
- Using the supplied audio input cable, you can place the module up to 6 feet (2 m) away from the multimedia sound source. If you put the module farther away, use an audio input extension cable available from any retail electronics store.

Positioning the satellite speakers

These speakers are designed to sit upright on your desk, or be mounted on your monitor with the supplied speaker brackets. The speakers are magnetically shielded to prevent interference when they are on or near your monitor. Using the supplied speaker cables, you can place the satellite speakers up to 6 feet (2 m) away from the module.

If placing your speakers on the desktop:

- Attach the three small rubber feet to each satellite speaker as indicated by the indentations on the bottom of each speaker.
- Place speakers facing you, at an equal distance on either side of monitor.
- Place both speakers a maximum of 3 feet (90 cm) from the edge of the screen, and at approximately the same height.

⚠ CAUTION: Choose a stable, level surface for the speakers. Vibration can cause the speakers to move, particularly on smooth surfaces like marble, glass, or highly polished wood. If needed, you may obtain additional rubber feet from Bose® Customer Service. To contact Customer Service, refer to the address sheet included in the product carton.

If mounting speakers on your monitor (Figure 4):

Figure 4

Mounting the bracket

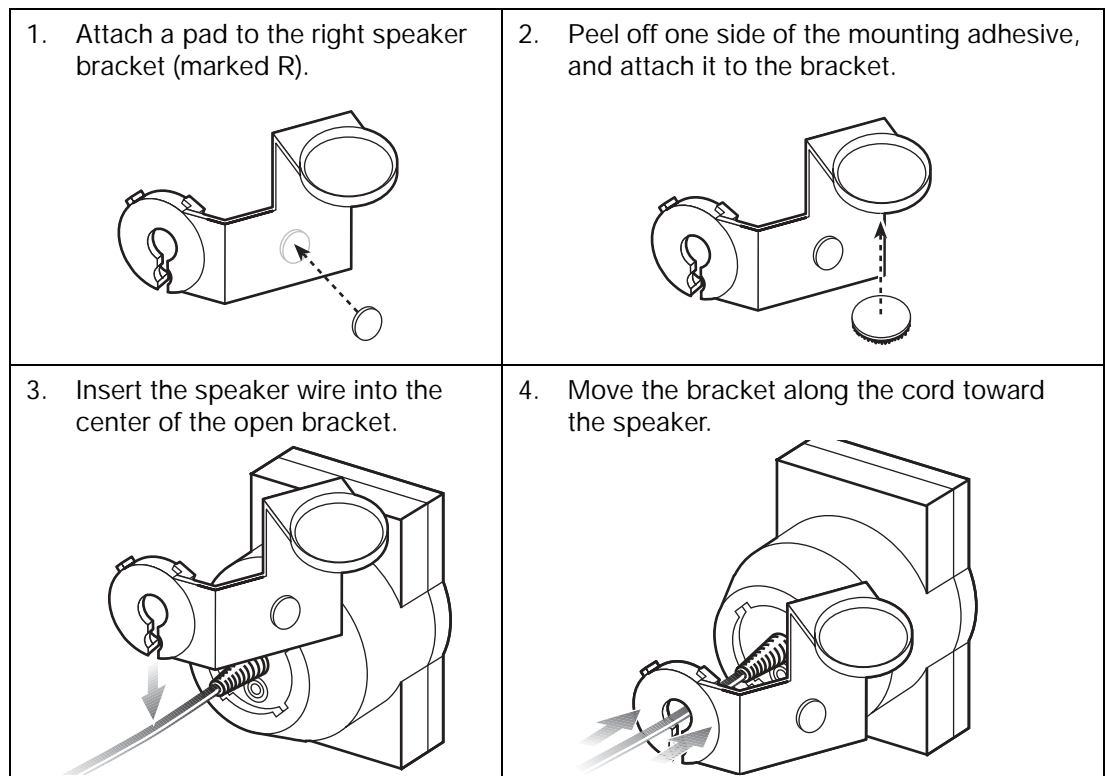

5. Center the bracket opening over the screw hole and press the bracket snugly into the speaker cutouts. Rotate the bracket counterclockwise to secure. Install supplied screw.

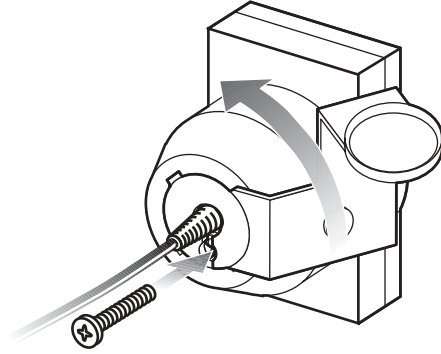

6. Peel off the remaining tape on the mounting adhesive, and attach the bracket to the appropriate side of the monitor.

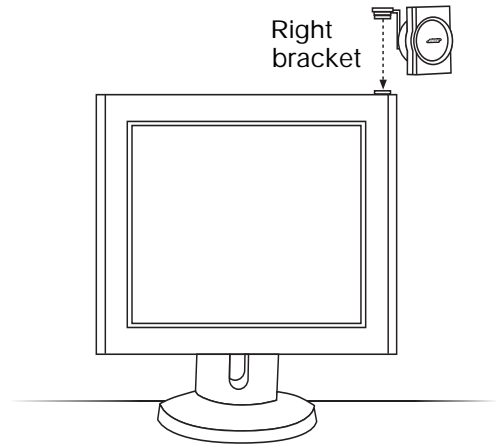

7. Repeat steps 1-6 for the left bracket, marked L.

🎵 **Note:** The speakers mounted on the monitor are designed to perform at their best when they are angled slightly away from the listener. This orientation provides the most lifelike performance for the seated listener, and expands coverage for other listeners in the room.

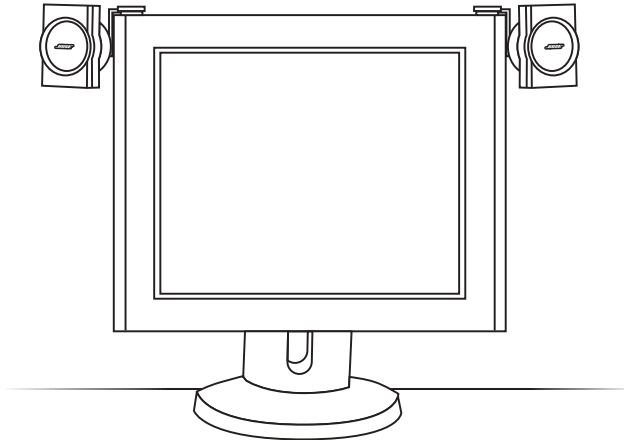

Making connections

Labeled jacks on the rear of the Acoustimass® module and the custom cables supplied with the system permit fast and easy hookup (Figure 5).

⚠ CAUTION: Do not plug the Acoustimass module into an AC power (mains) outlet until all the source components are connected to the module.

Figure 5

Making connections

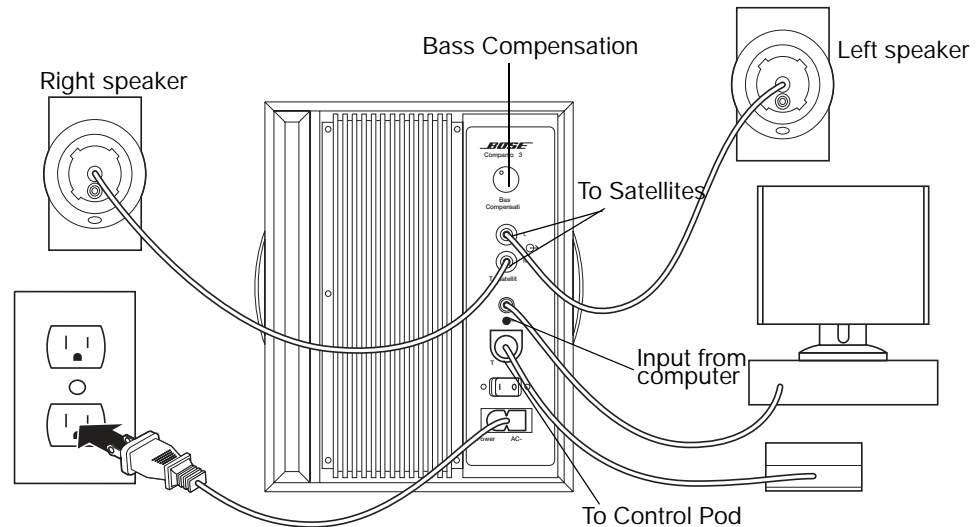

To Connect:

- *Speakers to the Acoustimass module;* Plug each speaker connector into the corresponding "L" or "R" jack marked "To Satellite", on the rear of the module.
- *Control pod to the Acoustimass module;* Plug the control pod cable into the jack marked "Control Pod", on the rear of the Acoustimass module.
- *Sound source to the Acoustimass module;* Connect one end of the audio input cable to the "Input from computer" jack on your Acoustimass module. Connect the other end to your computer's audio output jack.

♪ Note: If your computer only has two phono jacks, instead of a stereo mini jack, you will need an audio adapter cable. Connect the audio input cable from your module to the adapter cable. Then insert the ends of the adapter cable into your computer's stereo phono jacks.

To make the final connection and power the system

1. Insert the small connector end of the power cord into the AC INPUT jack on the module.
2. Insert the large end of the cord into an AC power (mains) outlet.
3. Push in the power button to turn on your system.
The LED on the control pod will light up yellow indicating standby mode.

Additional Connections

To connect an additional sound source:

To connect an external CD or MP3 player to your system, plug the cable from the sound source into the input jack on the tethered control pod (Figure 6).

To connect headphones:

Insert the headphone connector into the headphone jack on the tethered control pod.

♪ Note: Connecting headphones will silence the output from your speakers.

Operating the Companion® 3 multimedia speaker system

Turning your speaker system on and off

1. Turn on your computer or sound source.
2. Turn the power switch on the back of the Acoustimass® module to ON (I).

Note: To conserve energy, your system can be put into standby mode. The mute or standby mode is activated by touching the center portion of the control pod.

Adjusting the sound

The acoustics of your listening room affect the sound quality of any speaker system. Upholstered furniture, wall-to-wall carpets, or heavy drapes can muffle the treble (high frequencies). Bare floors and walls and unupholstered furniture reflect the treble and may cause it to sound too shrill.

Bass

After listening to your speaker system, you may wish to adjust the sound. Use the bass compensation control on the Acoustimass module. Turn the control clockwise to increase, or counterclockwise to decrease bass. You may also adjust the placement of the module to affect bass; simply aim the port of the module away from the wall to decrease bass, or toward the wall to increase bass.

Volume

Use the volume control on the control pod. Rotate the outer ring clockwise to increase, or counterclockwise to decrease the volume (Figure 6).

To mute the system, gently tap the silver touch-sensitive panel on the remote. Tap again to unmute. The indicator light turns yellow when the system is muted, and green when it is active.

Figure 6

Tethered control pod features

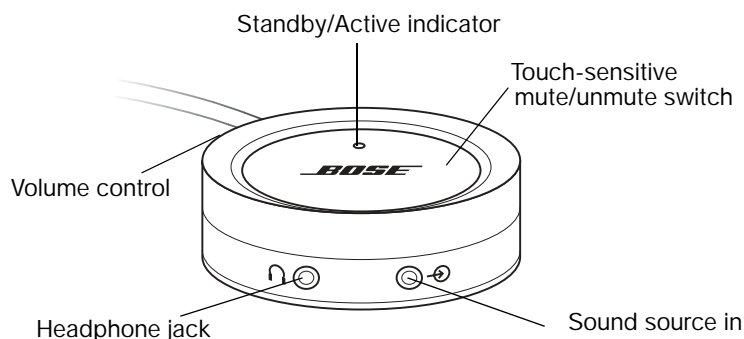

Note: Using the volume controls in their maximum position may reduce the speaker system's maximum volume, by causing the internal protection circuitry to engage.

If you wish to control volume at the sound source instead of from the control pod, set the volume control on the remote near maximum volume; then make all other adjustments using the volume control on your sound source. For instance, you may be able to control the volume on your computer from its control panel.

Troubleshooting

If you have a problem with your Companion® 3 multimedia speaker system, try the following solutions. If you still have trouble with your system, turn off the multimedia sound source and disconnect the speaker system. Contact your authorized Bose dealer. The dealer will check for any defects and arrange for service by an authorized Bose® service center. Bose Corporation will make every effort to remedy your problem within the terms of the warranty.

Problem	What to do
The speaker system does not play	<ul style="list-style-type: none"> • Make sure connections are secure (see “Making connections” on page 9). Check your speaker wires for cuts or frays which can cause a short circuit. • Ensure the sound source is plugged in and playing at an audible volume. • Make sure the power is on and the system is not muted. The LED on the control pod should be green when unmuted. • If using a PC, check your sound card settings to make sure the “Digital output only” setting is turned OFF. This setting is typically found in the Options menu of the volume control icon. This icon is usually located in the lower right hand corner of the Windows desktop.
The speaker system sound seems distorted	<ul style="list-style-type: none"> • Decrease the volume at the sound source and increase the volume on the control pod.
A satellite speaker doesn't play or sounds distorted	<ul style="list-style-type: none"> • Check all the connections between the satellite speakers, control pod, sound source and the Acoustimass® module. Insert the audio connectors completely into the jacks on the module. • At the Acoustimass module, switch the wire connected to the left satellite with the wire connected to the right satellite. If the problem remains in the same satellite, the problem is with that satellite speaker. If the problem switches to the other satellite (the one that previously played), the problem is with the sound source or the Acoustimass module. • To determine if the problem is in the sound source or the Acoustimass module, disconnect the audio input cable from the sound source. Plug it into another sound source (such as a portable CD player headphone jack) and adjust the volume on the sound source. If the Companion 3 speaker system operates properly, the problem is in the original sound source. If the problem remains, then the problem is in the Acoustimass module.

Maintaining the Companion® 3 Multimedia Speaker System

Cleaning the system

- Wipe with a damp cloth.
- Do not use solvents or chemicals.
- Do not put liquids or objects on the back panel or in the opening on the Acoustimass® module, speaker grilles or control pod.

Warranty period

The Companion® 3 multimedia speaker system is covered by a limited transferable warranty. Details of the warranty are provided on the product registration card that came with your system. Please fill out the information section on your warranty card and mail it to Bose.

Technical Information

Features

Built-in amplification
Active equalization
Automatic protection circuitry
TrueSpace® stereo signal processing

Driver complement

Two magnetically-shielded 2-inch (5.0 cm) long-throw, wide-range transducers
One 5.25-inch (13.3 cm) woofer

Power Rating

USA/Canada: 115VAC~50/60 Hz
International: 230VAC~50/60 Hz

Dimensions (approximate)

Satellite speakers: 3¹/₂"H x 2¹/₂"W x 2³/₈"D (8.89 cm x 6.35 cm x 6.10 cm)
Acoustimass® module: 8⁵/₈"H x 7¹/₈"W x 14"D (21.8 cm x 18 cm x 35.56 cm)
Control pod: 2¹/₂"D x 1¹/₈"H (6.35 cm x 2.79 cm)

Weight (approximate)

One satellite speaker, unpacked: 0.5 lbs (0.23 kg)
Acoustimass module, unpacked: 15.4 lbs (6.98 kg)

Finish

Acoustimass module: Scratch-resistant, satin-finished vinyl
Satellite speakers: Painted polymer finish



©2003 Bose Corporation, The Mountain
Framingham, MA 01701-9168 USA
271883 AM Rev.00 JN31136