

KitchenAid® 30" Freestanding and Slide-In Electric Range

PRODUCT MODEL NUMBERS

KERC601HBL	KESC307HBL
KERC601HBT	KESC307HBS
KERC601HWH	KESC307HBT
KERC607HBL	KESC307HWH
KERC607HBS	KESC307HWW
KERC607HBT	
KERC607HWH	
KERC607HWW	
KESC300HBL	
KESC300HBT	
KESC300HWH	

Electrical: Use 8-gauge solid copper wire. A four-wire or three-wire, single-phase, 120/240-volt, 60-Hz, AC-only, electrical supply is required on a 50-ampere maximum circuit, (or, if specified on the model/serial rating plate, a four-wire or three-wire, single-phase 120/208-volt, 60 Hz, AC-only electrical supply is available, a 40-ampere maximum circuit), fused on both sides of the line. A time-delay fuse or circuit breaker is recommended. The model/serial rating plate is located on the oven frame behind the drawer.

OVERALL DIMENSIONS

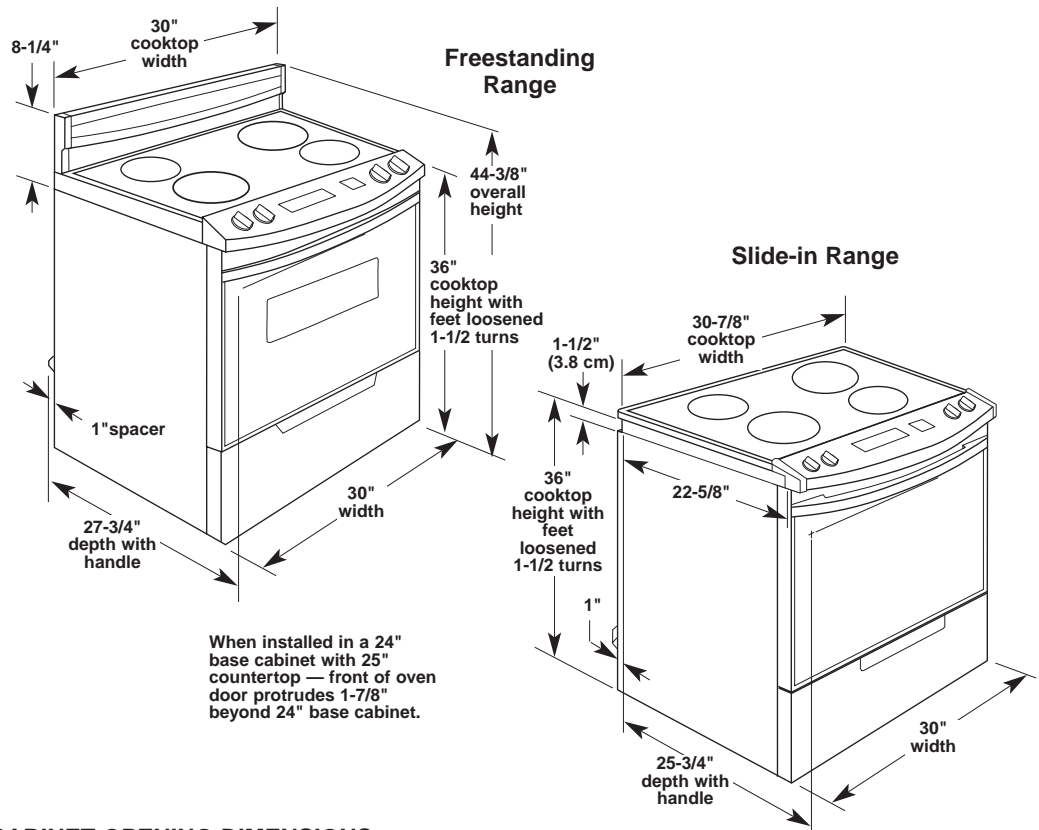

SLIDE-IN RANGE COUNTERTOP PREPARATION

The cooktop sides of the slide-in range fit over the cutout edge of your countertop.

If you have a square finish (flat) countertop and the opening width is 30", no countertop preparation is required.

Formed front-edged countertops: Must have molded edge shaved flat 1/2" from each front corner of opening.

Tile countertops may need trim cut back 1/2" from each front corner and/or rounded edge flattened.

If countertop opening width is greater than 30", adjust the 1/2" dimension.

Countertop must be level. Place level on countertop, first side to side; then front to back. If countertop is not level, range will not be level. Oven must be level for satisfactory baking conditions.

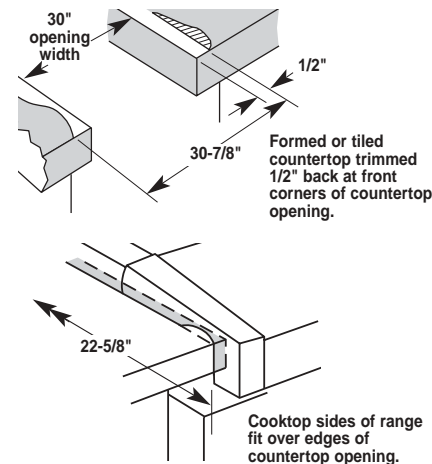

CABINET OPENING DIMENSIONS

25" countertop depth and 24" base cabinet depth, 36" countertop height

