

# downdraft ventilation

**INNOVATION AT ITS FINEST:** the uniquely-styled UCV Universal Cook 'n' Vent®, Thermador's space-saving solution to ventilation. Our ultra-quiet, smooth-movement, integrated downdraft ventilation systems rise to a full 15 inches when in use and then lower out of sight. At its full height, it is well above even the tallest pans and is 50 to 80 percent higher than previous models. The precise 3-speed control offers maximum versatility. Best of all, the powerful UCV Cook 'n' Vent quietly eliminates heat, odors, smoke and grease with its powerful integral or remote blower options. And when it's time to clean the filter, a 40-hour "time to clean filter" reminder appears. Downdraft ventilation has never been so innovative.



- UCV COOK 'N' VENT RAISES INTO POSITION 15 INCHES WHEN IN USE, THEN LOWERS OUT OF SIGHT
- REVERSES DIRECTION OF TRAVEL AND STOPS WHEN OBSTRUCTIONS ARE ENCOUNTERED
- RAISES AND LOWERS QUIETLY WITH SMOOTH, RELIABLE MOVEMENT
- MAXIMIZES GREASE CAPTURE CAPABILITY AND AIR FLOW
- 3 SPEED ELECTRONIC CONTROL PROVIDES VENTILATION POWER TO SUIT YOUR NEEDS
- DELAYED AUTO SHUT-OFF FOR CONTINUED AIR CLEANING
- 40 HOUR "TIME TO CLEAN FILTER" REMINDER
- "ALL IN ONE" INTEGRATED ASSEMBLY OF SPLATTER GUARD, GREASE TRAY AND FILTERS FOR EASY CLEAN-UP
- DISHWASHER-SAFE FILTERS

create.

**Thermador®**



## UCV Cut-Out Dimensions

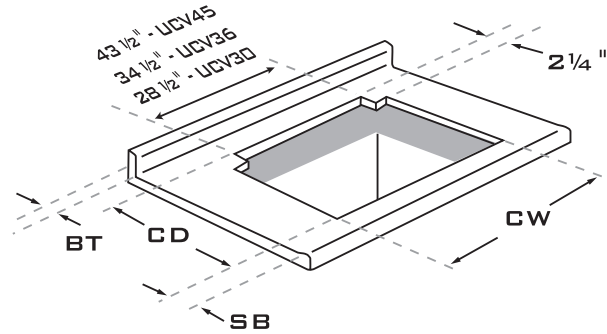

MODEL NUMBER	UCV30A_	UCV36A_	UCV45A_
APPEARANCE			
INSTALLATION TYPE	WALL/ISLAND	WALL/ISLAND	WALL/ISLAND
FINISH (TOP CAP): BLACK, WHITE OR STAINLESS STEEL	■	■	■
RETRACTABLE VENT HEIGHT	15"	15"	15"
PERFORMANCE			
INTEGRAL VENTILATOR OPTIONS (CFM)	VTN600CVA (600)	VTN600CVA (600)	VTN600CVA (600)
*REMOTE VENTILATOR OPTIONS (CFM)	VTR600R (600) VTR1000Q (1000)	VTR600R (600) VTR1000Q (1000)	VTR600R (600) VTR1000Q (1000)
CONVENIENCE			
UP/DOWN CONTROL	ONE TOUCH	ONE TOUCH	ONE TOUCH
VENT CONTROL	3 SPEED	3 SPEED	3 SPEED
DISHWASHER-SAFE FILTERS	■	■	■
DELAYED SHUT-OFF	■	■	■
TIME TO CLEAN FILTER	■	■	■
CUT-OUT DIMENSIONS	30" COOKTOPS	36" COOKTOPS	45" COOKTOPS
ELECTRIC (CET, CEP, CEM SERIES)			
CW	28 3/4"	34 3/4"	43 3/4"
CD	22 1/8"	22 1/8"	22 1/8"
SB	2 1/2"	2 1/2"	2 1/2"
BT	0	0	0
GAS (SGS & SGSX STAR SERIES)			
CW	28 15/16"	34 15/16"	43 15/16"
CD	22 1/4"	22 1/4"	22 1/4"
SB	1 1/2"	1 1/2"	1 1/2"
BT	3/4"	3/4"	3/4"
GENERAL INFORMATION			
DISCHARGE DIRECTION	DOWN/SIDE	DOWN/SIDE	DOWN/SIDE
120 VOLTS, 3 PRONG GROUNDING PLUG, 60HZ, SINGLE PHASE A.C.	■	■	■
TOTAL AMPS (MAX.)	10	10	10

Thermador reserves the right to change product specifications or design without notice. Consult installation instructions prior to beginning installation process.

\* Requires CVT7 or CVT 314 transition.

1-800-656-9226  
www.thermador.com

**Thermador**®