

Operating and Installation Instructions

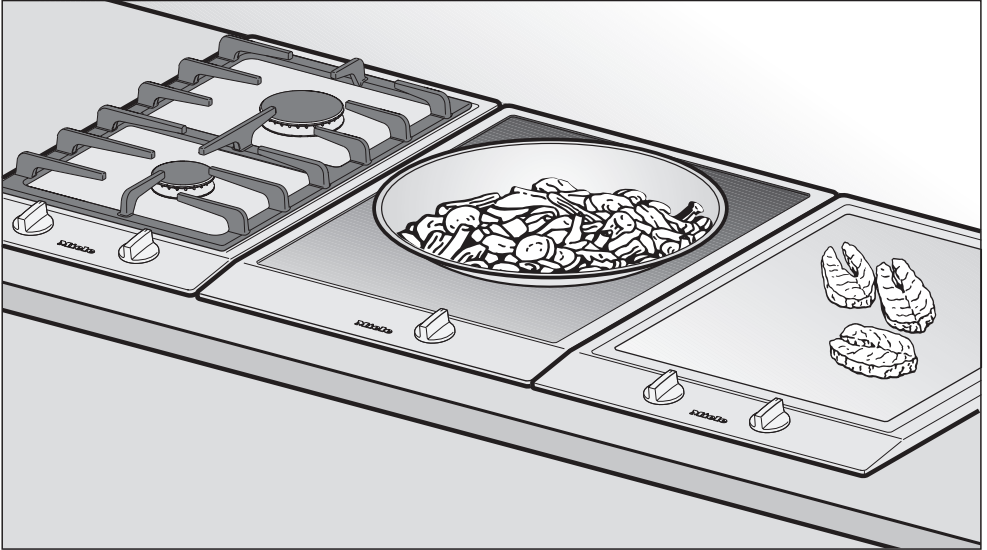

Ceramic Combiset CS 1112 CS 1122

To prevent accidents and
appliance damage,
read these instructions

before
installation or use.

en - US

M.-Nr. 07 346 400

Contents

IMPORTANT SAFETY INSTRUCTIONS	3
Description of the combiset	7
CS 1112	7
CS 1122	8
Before using for the first time	9
Clean the combiset	9
How the burners work	10
Use	11
Turning a burner On/Off	11
Turning on the second ring on a Variable/Extended burner	11
Residual Heat Indicator	12
Settings	13
Overheat protection	14
Selecting cookware	15
Cleaning and care	17
Frequently asked questions	19
Technical Service	20
IMPORTANT INSTALLATION SAFETY INSTRUCTIONS	24
Installation	27
Installation dimensions CS 1112	28
Installation dimensions CS 1122	29
Installation of multiple appliances	31
Attach the spring clips and support bars	34
Sealing	37
Tiled surfaces	37
Electrical connection	38
Help protect our environment	39

IMPORTANT SAFETY INSTRUCTIONS

WARNING- When using your appliance follow basic precautions, including the following:

Read all instructions before installation or use to prevent injury and appliance damage.

This appliance conforms to all uniform safety codes and regulations.

Keep these operating instructions in a safe place and pass them on to any future user.

SAVE THESE INSTRUCTIONS

Correct usage

▶ Only use the combiset for residential cooking, and for the purposes described in this manual.

Other uses are not permitted and can be dangerous.

▶ Persons who lack physical, sensory or mental abilities, or experience with the appliance should not use it without supervision or instruction by a responsible person.

Children

▶ Children should not be left unattended in an area where the appliance is in use. Never allow children to sit or stand on any part of the appliance.

Caution: Do not store items of interest to children in cabinets above the appliance. Children climbing on the appliance to reach these items could be injured.

▶ The appliance is hot during use and remains so for some time after being switched off. Keep children away from the appliance.

▶ Ensure that any packing material, is disposed of safely and kept out of the reach of children. Danger of suffocation!

▶ Keep all pots and pans out of the reach of children. Danger of burning or scalding.

IMPORTANT SAFETY INSTRUCTIONS

Technical safety

▶ Installation, repair and maintenance work should be performed by a Miele authorized service technician. Work by unqualified persons could be dangerous and may void the warranty.

▶ Be sure your appliance is properly installed and grounded by a qualified technician.

▶ Before installing the combiset, check for externally visible damage.

Do not operate a damaged appliance.

▶ To guarantee the electrical safety of this appliance, continuity must exist between the appliance and an effective grounding system. It is imperative that this basic safety requirement be met. If there is any doubt, have the electrical system of the house checked by a qualified electrician.

▶ Before installation, make sure that the voltage and frequency listed on the rating label correspond with the household electrical supply. This data must correspond to prevent injury and appliance damage. Consult a qualified electrician if in doubt.

▶ Do not use an extension cord to connect this appliance to electricity. Extension cords do not guarantee the required safety of the appliance.

▶ Install the appliance so that the power cord does not come into contact with any portion of the combiset which may become hot during use.

▶ Before servicing, disconnect the appliance from the main power supply.

▶ Do not operate any appliance with a damaged cord or plug, or if the appliance has been damaged in any manner. Contact Miele's Technical Service Department.

▶ Under no circumstances open the outer casing of the appliance.

▶ While the appliance is under warranty repairs should only be performed by an authorized service technician. Otherwise the warranty is void.

▶ In the event of any damage to the appliance, it must be turned off immediately and disconnected from the main power supply. Contact Miele's Technical Service Department. Do not use the appliance until it has been repaired. Ensure power is not supplied to the appliance until repair work is completed.

IMPORTANT SAFETY INSTRUCTIONS

▶ Defective components should be replaced by Miele original spare parts only. Only with these parts can the manufacturer guarantee the safety of the appliance.

▶ Do not cook on a broken combiset. Any breakages or cracks in the ceramic surface of the appliance are defects and must be treated as such. If the combiset should break, cleaning solutions and spills may penetrate the broken combiset and create a risk of electric shock. Do not use the appliance until it has been repaired.

▶ Be sure that the power cord does not come in contact with any "hot spots" after installation.

Safety

▶ The appliance is hot during use and remains so for some time after being switched off. Be careful not to touch the appliance if it may still be hot.

▶ Protect your hands with oven mitts or potholders when using the appliance. Use only dry, heat resistant potholders. Moist or damp potholders used on hot surfaces can result in steam burns. Do not let the potholder touch the hot heating elements. Do not use towels or other bulky items near the appliance.

▶ Do not heat unopened containers. Built-up pressure may cause the container to burst and result in injury.

▶ Do not flambé under an exhaust hood. Flames could be drawn up into the hood by the suction and the grease filters may ignite.

▶ Never use the appliance to heat a room. Due to the high temperatures radiated, objects left near the appliance could catch fire.

▶ Do not use the appliance until it has been properly installed in the countertop.

▶ Do not store items on the appliance when not in use. Items could melt or catch fire from residual heat or if the appliance is turned on inadvertently. Always switch the cooking zone(s) off after use.

▶ Never cover the appliance with a cloth. A fire may result.

▶ Be aware of loose fitting or hanging garments when operating the appliance, they may present a fire hazard.

▶ Never leave an appliance unattended at high settings or when cooking with oil or fat. Overheated oil could ignite. Always heat oil slowly, monitoring it as it heats.

▶ Do not store aerosols, combustibles or any other easily flammable materials underneath or adjacent to the appliance.

▶ Do not use water on grease fires. Smother or use a dry chemical or foam-type extinguisher on any fire or flame.

▶ Make certain that the power cords of small appliances do not come in contact with the appliance. The insulation of the cable could become damaged. Danger of electric shock!

IMPORTANT SAFETY INSTRUCTIONS

- ▶ Be careful not to drop anything on the ceramic surface of the combiset. Even lightweight objects may cause damage.
- ▶ Use the proper pan size. Select cookware with flat bottoms large enough to cover the heating element. Using undersized cookware will expose a portion of the heating element and may result in ignition of clothing or handles becoming hot. The proper size pot or pan will also improve efficiency.
- ▶ Pot and pan handles should be turned inward and not extend over the countertop to reduce the risk of burns, ignition of flammable materials, and spills.
- ▶ Do not use pots or pans with pronounced edges or ridges on the ceramic combiset. These could scratch the combiset permanently. See "Selecting cookware" for more information. Grains of salt and sand can cause scratches. Make sure that the bases of any pots and pans are clean, free of any fat or oils and are dry.
- ▶ To prevent damage to the combiset do not use pots and pans with thin bases on the combiset. Never heat an empty pan unless the pan manufacturer states that you can do so.
- ▶ Before using glass, glass/ceramic, ceramic, earthenware or other glazed cookware verify that they can be used on a cooking surface.
- ▶ To prevent burns and breathing difficulty, allow the combiset to cool before cleaning. Some cleaners may produce toxic fumes if applied to a hot surface.
- ▶ Keep the combiset clean. Salt, sugar, and grit can cause scratches.
- ▶ When wiping spills on a hot combiset with a wet sponge or cloth, be careful to avoid steam burns.
- ▶ Do not let flammable materials, i.e. cooking grease, accumulate on the appliance.
- ▶ Do not use a steam cleaner to clean this appliance. Steam could penetrate electrical components and cause a short circuit.
- ▶ Do not allow either solid or liquid sugar, pieces of plastic or foil to fall on the burners when they are hot. If these residues are allowed to cool on the ceramic surface pitting or even cracking may occur.
- ▶ Any spills should be removed as quickly as possible to prevent them from burning on and becoming difficult to remove.

**SAVE THESE INSTRUCTIONS
AND REVIEW THEM
PERIODICALLY**

Description of the combiset

CS 1112

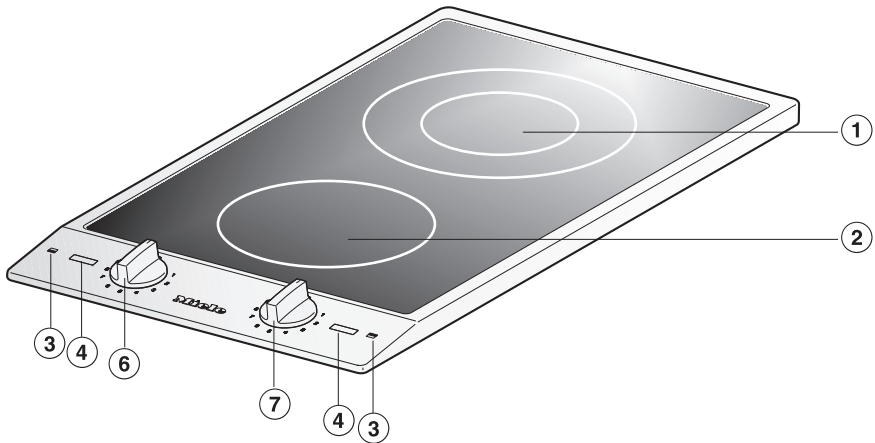

- ① Variable burner :
Ø 4" or 7" (100 mm or 180 mm) -
Power: 700 W or 1800 W
- ② Standard burner :
Ø 5 ¹¹/₁₆" (145 mm) -
Power: 1200 W
- ③ Burner indicators
- ④ Display

Control knobs for the burners:

- ⑥ Standard burner (front)
- ⑦ Variable burner (rear)

Indicators



- ⑪ On/Off indicator
- ⑫ Symbol for the outer-ring of the variable burner
- ⑬ "Residual Heat" indicator

Description of the combiset

CS 1122

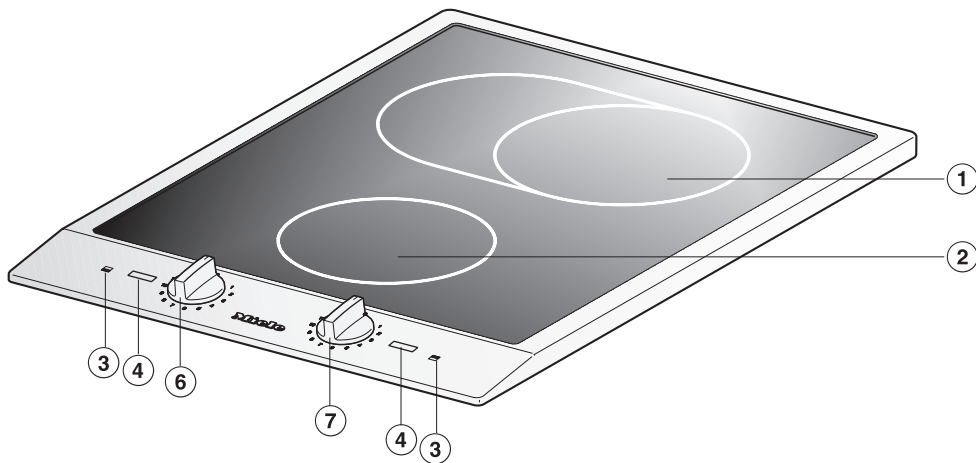

① Extended burner
Ø 7" or 7" x 10 ⁷/₁₆"
(180 mm or 180 mm x 265 mm) -
Power: 1500 W / 2400 W

② Standard burner
Ø 5 ¹¹/₁₆" (145 mm) -
Power: 1200 W

③ Burner indicators

④ Display

Control knobs for the burners:

⑥ Standard burner (front)

⑦ Extended burner (rear)

Indicators



⑪ ⑫ ⑬

⑪ On/Off indicator

⑫ Extended burner indicator

⑬ "Residual Heat" indicator

Before using for the first time

Clean the combiset

- Before using for the first time, clean the appliance with a damp cloth and dry with a soft cloth.

Do not use liquid dish soap to clean the combiset, this may cause permanent blue discolorations.

Heat the combiset

Metal components of the appliance have a protective coating which may give off a slight odor the first time the appliance is heated.

The smell will dissipate after a short time and does not indicate a faulty connection or appliance defect.

How the burners work

One-ring burners use one heating strip, and two-ring burners and grill zones use two heating strips. Depending on the model, the heating strips may be separated by a certain distance. See the illustrations.

Every burner is equipped with overheat protection (inside temperature limiter), to prevent the glass ceramic combiset from overheating (see the section on "Overheat protection").

When you select a power setting, the heating element switches on and you will see the heating strip through the combiset.

The power setting determines how hot the burner will get, and this is electronically regulated. This means that the burner will switch on and off as needed to maintain the selected power level.

One-ring burner

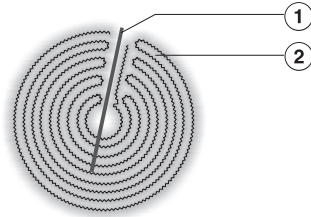

- ① Overheating protection
- ② Heating strip

Two-ring burner

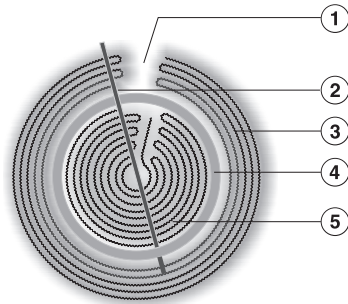

- ① Technical detail (not a defect)
- ② Overheating protection
- ③ Outside heating strip
- ④ Separation strip
- ⑤ Inside heating strip

Turning a burner On/Off

- To turn a burner **on**, press the control knob down and turn it **clockwise** ① to the desired setting.

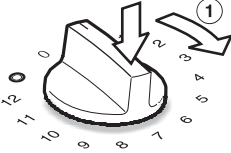

- To turn a burner **off**, turn the control knob **counterclockwise** ② to "0".

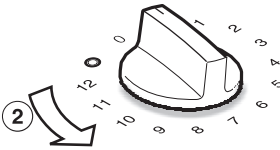

Turning on the second ring on a Variable/Extended burner

- Press the control knob down and turn it clockwise past "12" to the ☉ symbol.
- Then turn the control knob counterclockwise to the desired setting.

Turning off the burner will also turn off the second ring. When the cooking zone is turned back on again, only the inside ring will be active.

Do not turn a burner on without pressing the control knob down, and do not turn the knob past "12" or ☉ to reach "0". This will result in damage.

When selecting level "12", make sure that the control knob is set exactly to the "12" position.

Use

Residual Heat Indicator

When a cooking zone is switched on, the On/Off indicator will light followed by the residual heat indicator.

When the cooking zone is switched off, the On/Off indicator goes out. The residual heat indicator will turn off once the cooking zone is safe to the touch.

Do not touch the burner or rest any objects on the combiset when the residual heat indicator is on. Danger of burns!

Settings

Use for	Power level*
Melt butter, chocolate, etc. Dissolving gelatine Prepare yogurt	1 - 2
Warming small quantities of food/liquid Keeping delicate dishes warm Cooking rice, Thawing frozen vegetables	1 - 3
Warming liquid or half-set foods Thickening sauces, e.g., hollandaise sauce Cooking rice pudding	3 - 5
Defrosting frozen foods Steaming vegetables, fish, etc. Cooking pasta, soups, etc. Steaming grains	4 - 6
Boiling and continued cooking of large quantities of food	7
Gently sautéing fish, cutlets, sausages, fried eggs, etc. (without smoking the oil/fat)	8 - 9
Frying pancakes, crepes, etc.	9 - 11
Boiling large quantities of water Parboil	11 - 12
Symbol for the second heating ring	☉

* These settings are intended as guidelines only. When cooking with large pots, large quantities or without using a lid, a higher setting is needed. For smaller quantities select a lower setting.

Overheat protection

Each cooking zone is equipped with a temperature limiter. This feature automatically turns off the heating element before the glass ceramic becomes too hot. Once the ceramic surface has cooled to a safe temperature the heating element will automatically turn back on.

The overheat protection may be activated by:

- turning on a burner without putting a pan on it.
- heating an empty pan.
- an uneven pan not sitting evenly on the burner.
- the pan not conducting heat properly.

If the heating elements cycle on and off, even at the highest setting, the overheating protection has been activated.

Selecting cookware

Following these tips will allow you to make the most of your ceramic combiset.

The cooking surface

The ceramic combiset is made of an extremely hard and durable material. The surface is scratch resistant, not scratch proof. Avoid using cookware with ridged bottoms. Ridged pots with dirty or chipped enamel bottoms may scratch the combiset if they are pulled across the ceramic surface.

Make sure the combiset and pot bottoms are clean before cooking. Certain items, particularly sugar grains or crystallized liquids such as molasses or syrups are harder than ceramic and can scratch the surface if they are not cleaned off immediately. Small or light scratches will not affect the safety or performance of the combiset.

Pots and pans

Special cookware is not required, but as is true with all types of cooking appliances, the better the cookware, the better the performance.

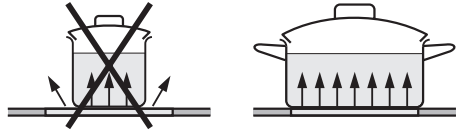

- For the most even and energy efficient cooking, the diameter of the pots/pans should match the diameter of the burners as closely as possible.

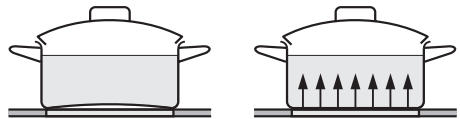

- Use cookware with thick, flat, smooth bottoms. Slightly concave bottoms will also work adequately. Pots with convex bottoms will not cook well.

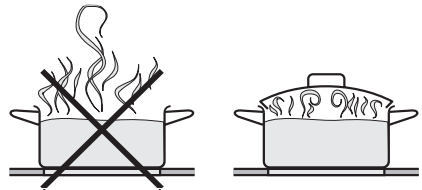

- Whenever possible, keep pots and pans closed while cooking. This helps keep in the most possible heat.
- For longer cooking periods, you can switch off the cooking zone 5 to 10 minutes before the total cooking time is completed. The residual heat will continue to cook the food.

Selecting cookware

Copper bottom and aluminum pans

may leave a residue on the combiset in the form of metallic lines. This is normal. These lines can be removed using a non-abrasive ceramic combiset cleaner or a shielded scraper blade.

Be sure to clean the combiset after each use. Each time this residue is allowed to melt it becomes harder to remove and may mar the appearance of the combiset. Let the combiset cool before cleaning.

Cast iron, glass or stoneware should not be used because they have poor heat transfer and may scratch the combiset surface.

Do not use a steam cleaner to clean this appliance. Steam could penetrate electrical components and cause a short circuit. Pressurized steam could cause permanent damage to the surface.

Do not use any sharp pointed objects which could damage the seal between the ceramic surface, the surrounding frame and the countertop.

Never use abrasive cleaners, caustic (oven) cleaners, dishwasher detergent, scouring pads, steel wool or hard brushes. They will damage the surface.

The ceramic surface can be cleaned using a cleaner for ceramic surfaces. Follow the manufacturer's instructions.

Make sure that no cleaner residue remains on the ceramic surface by carefully wiping the combiset with a damp cloth. They may damage the combiset or produce toxic fumes when heated.

Be sure that pot and pan bases are clean and dry.

After cleaning dry the ceramic surface with a soft cloth to prevent a build up of limescale deposits.

Clean any spills immediately before they become difficult to remove.

Clean the appliance regularly, preferably after each use. Allow the appliance to cool before cleaning.

Ceramic surfaces

- Wipe off any soiling using a damp cloth. Stubborn soiling is best removed with a shielded scraper blade.
- Apply a ceramic cleaner (available from Miele) using a soft cloth or paper towel.
- To remove any limescale deposits or metallic residue apply a ceramic cleaner using a soft cloth or use a shielded scraper blade if necessary.
- After cleaning wipe the ceramic surface with a damp cloth and dry.

A cleaner with a special additive to prevent water marks and smears on the ceramic surface may be used.

Any melted solids like **sugar, plastic or aluminum foil** should be removed as quickly as possible, while the burner is still warm. If they are allowed to harden the combiset may become pitted.

- Turn the burner off.
- Using a shielded scraper blade, scrape the melted item **immediately** off the burner while it is still hot.
Use caution: Danger of burns!
- Allow the combiset to cool and clean as previously described.

Cleaning and care

Stainless steel

Clean stainless steel surfaces with warm water and liquid dish soap applied with a non-abrasive sponge and then wipe dry with a soft cloth. Soak baked or hardened spills first to loosen them.

Stainless steel surfaces can be cleaned using a non-abrasive stainless steel cleaner (available from Miele).

To help prevent resoiling, a conditioner for stainless steel can also be used. Apply sparingly with even pressure.

Do not use stainless steel cleaner on or around the **printing**, it may rub off. Use only a soft sponge with a mild solution of warm water and liquid dish soap to clean this area.

Frequently asked questions

 Repairs should only be carried out by an authorized technician in accordance with local and national safety regulations. Unauthorized repairs could cause injury or appliance damage.

What if the appliance does not heat up after it is turned on?

Possible fault	Solution
The circuit breaker has tripped.	Check whether a fuse is blown. If the problem persists contact Miele.

What if a heating element turns off then on again?

Possible fault	Solution
The overheating protection has activated.	See "Overheating protection".

What if the food seems to take too long to boil?

Possible fault	Solution
The control knob may be set past level "12". When the knob is sitting between "12" and "0" the appliance operates at reduced power.	Turn the control knob exactly to "12".

Technical Service

In the event of a fault which you cannot easily fix yourself, please contact the Miele Technical Service Department at the address on the back of this booklet.

When contacting Technical Service please quote the serial number and model of the appliance.

Adhere rating label sticker supplied with the appliance below.

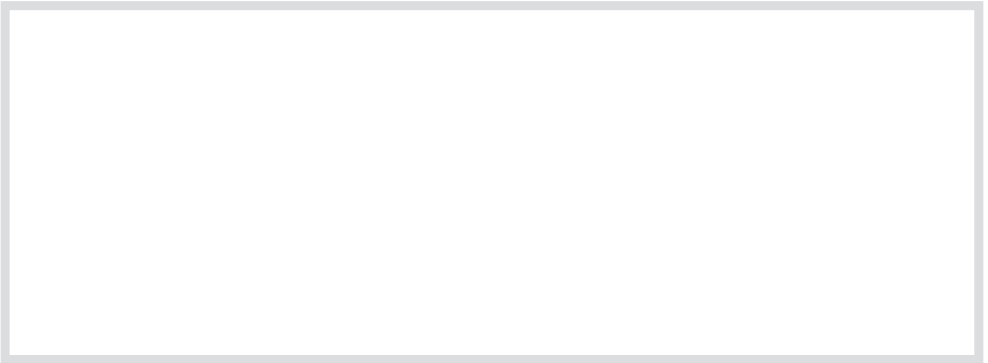

MieleCare

(USA only)

MieleCare, our Extended Service Contract program; gives you the assurance of knowing that your appliance investment is covered by 5 years of worry free ownership.

MieleCare is the only Extended Service Contract in the industry that guarantees repairs by a Miele Authorized Service Provider using genuine Miele parts. Only genuine Miele parts installed by factory trained professionals can guarantee the safety, reliability and longevity of your Miele appliance.

Please note that unless expressly approved in writing by the Miele Service department, Extended Service Contracts offered by other providers for Miele products will not be recognized by Miele. Our goal is to prevent unauthorized (and untrained) service personnel from working on your Miele products, possibly doing further damage to them, you and/or your home.

To learn more about **MieleCare** Extended Service Contracts, please contact your appliance dealer or visit us online at:

<http://miele.com/mielecare>

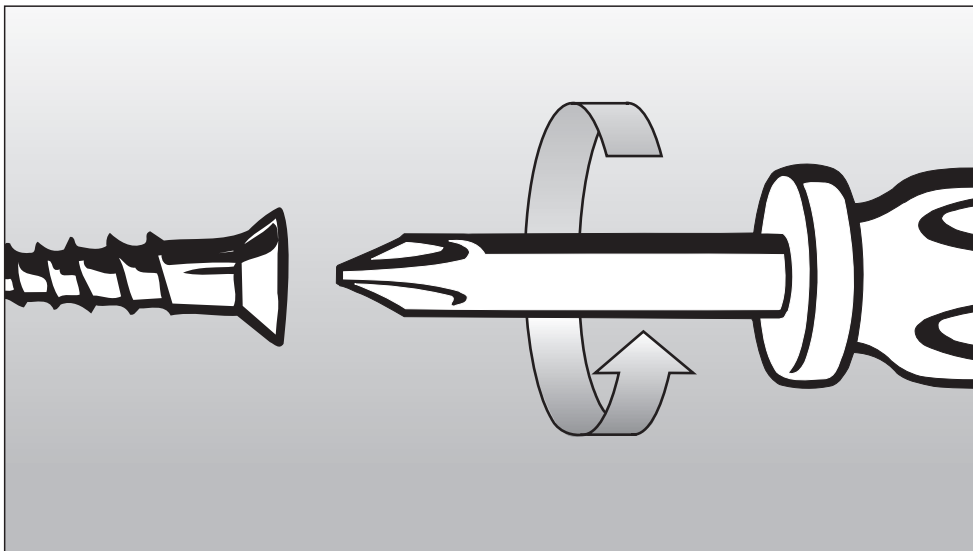

Installation Instructions

IMPORTANT: SAVE FOR THE LOCAL ELECTRICAL INSPECTOR'S USE

To prevent accidents
and appliance damage
read these instructions

before
installation or use.

IMPORTANT INSTALLATION SAFETY INSTRUCTIONS

Note to the installer:

Please leave this instruction book with the consumer for the local electrical inspector's use.

The minimum distances given in these Installation Instructions must be observed in order to ensure safe operation. Failure to do so increases the risk of fire.

The cabinetry and venting hood should be installed first to prevent damage to the combiset.

- ▶ The countertop must be bonded with heat resistant (212°F/100°C) adhesive to prevent distortion or dissolving. Any back splashes should be heat-resistant as well.
- ▶ The combiset must not be installed over a dishwasher, washer, dryer, refrigerator or freezer. Heat radiated by the combiset may damage them.
- ▶ To eliminate the risk of burns or fire by reaching over heated surfaces cabinet storage space above the appliance should be avoided. If cabinet storage is necessary, the risk can be reduced by installing a venting hood to project horizontally a minimum of 5" (127 mm) beyond the bottom of the cabinets.

▶ This appliance has not been designed for maritime use or for use in mobile installations such as recreational vehicles or aircraft. However, under certain conditions it may be possible for installation in these applications. Please contact the Miele Technical Service Department with specific requirements.

▶ Do not install this appliance above an oven unless the countertop is at least 1 ⁹/₁₆" (40 mm) thick.

▶ You must ensure the power cable for the appliance will not come into contact with the floor panel after installation, nor be subject to any mechanical strain.

▶ The appliance must not be permanently sealed into the countertop when installed. The sealing strip under the edge of the appliance provides a sufficient seal for the countertop. See "Sealing".

Keep this instruction book in a safe place for reference and pass it on to any future user.

IMPORTANT INSTALLATION SAFETY INSTRUCTIONS

Safety distances above the appliance

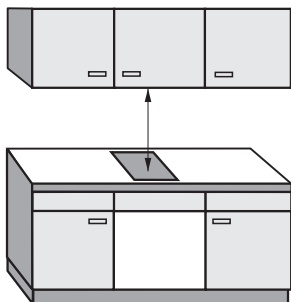

The minimum safety distance given by the hood manufacturer must be maintained between the combiset and the hood above it. See the installation instructions of the hood for these safety measurements.

If the hood manufacturers instructions are not available or if flammable objects are installed over the combiset (e.g. cabinets, utensil rail, etc.), a minimum safety distance of 30" (760 mm) must be maintained.

If there is more than one appliance beneath a hood (e.g. wok burner and electric combiset), and they have different minimum safety distances always observe the greater distance.

IMPORTANT INSTALLATION SAFETY INSTRUCTIONS

Safety distances to the sides of the appliance

The appliance should only be installed as shown in the illustrations, while maintaining the required safety distances shown. Do not install the appliance between two tall cabinets, this is a fire hazard.

A distance of at least 2" (50 mm) must be kept between the countertop cut-out and the rear wall because of the high temperatures radiated.

The minimum distance required from the countertop cut-out to the side wall ①:

2" (50 mm)	for	CS 1112 CS 1122 CS 1212 CS 1221 CS 1223 CS 1326 CS 1411
6" (150 mm)	for	CS 1312 CS 1322 CS 1421
10" (250 mm)	for	CS 1011 CS 1012 CS 1028

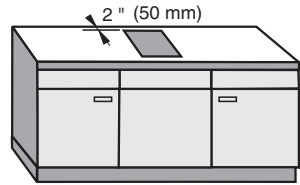
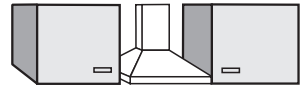

recommended

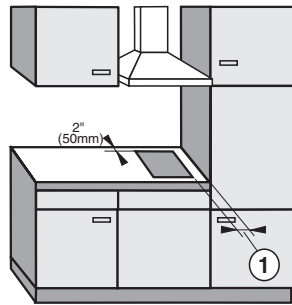

not recommended

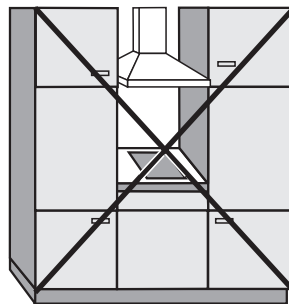

not allowed

Safety distance from the wall covering

If a wall covering is installed, a minimum safety distance must be maintained between the countertop cut-out and the covering, since high temperatures can damage these materials.

If the covering is made of a combustible material (such as wood), the distance between the countertop cut-out and the wall covering must be a minimum of 2" (50 mm).

For coverings made of non-combustible materials (such as metal, marble, granite or ceramic tiles) the minimum safety distance ⑤ between the countertop cut-out and the wall covering must be 2" (50 mm) minus the thickness of the covering.

For example: thickness of wall covering 9/16" (15 mm)

2" (50 mm) - 9/16" (15 mm) = minimum safety distance 1 3/8" (35 mm).

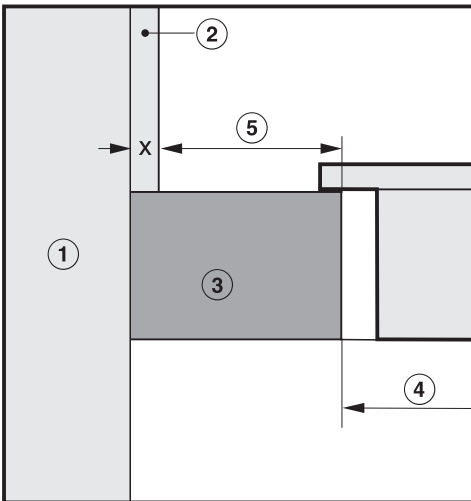

- ① Wall frame
- ② Wall covering
 x = thickness of the wall covering
- ③ Countertop
- ④ Countertop cut-out
- ⑤ Minimum safety distance
with flammable materials 2" (50 mm)
with non-flammable materials 2" (50 mm) minus x

Installation

Installation dimensions CS 1112

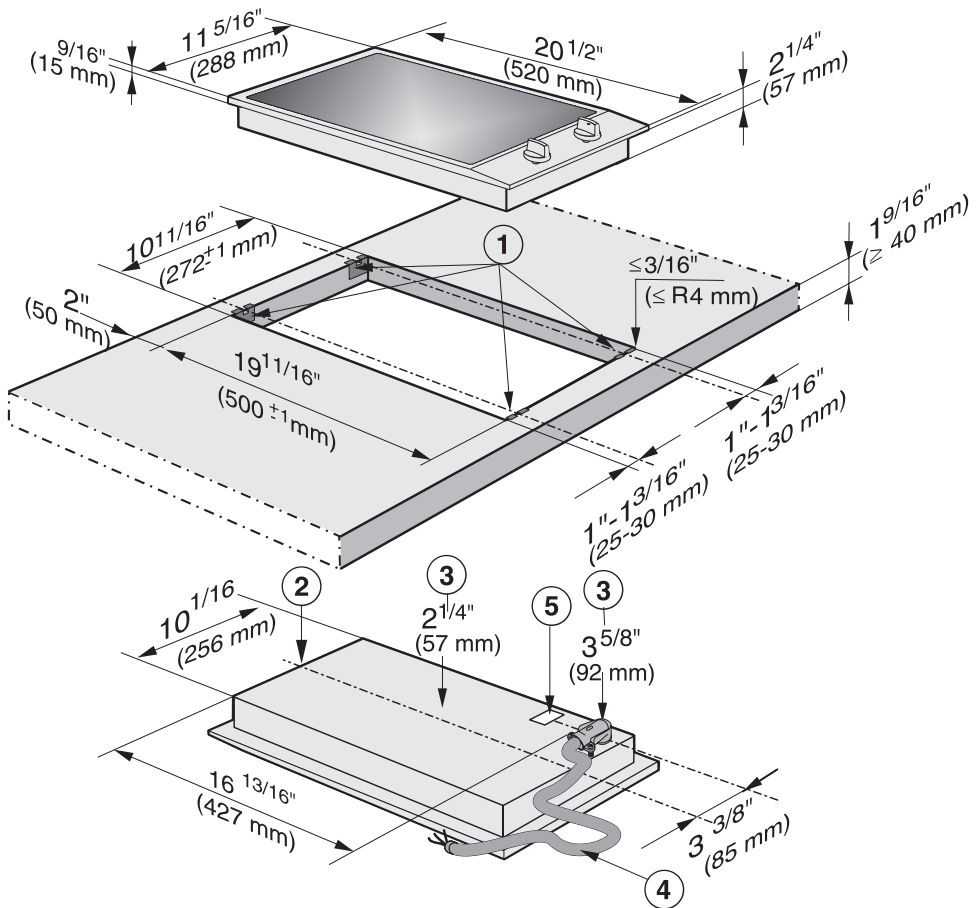

- ① Spring clips
- ② Appliance front
- ③ Installation height
- ④ Power supply box with connection cable, L = $78\frac{3}{4}''$ (2000 mm)
- ⑤ Rating label

Installation dimensions CS 1122

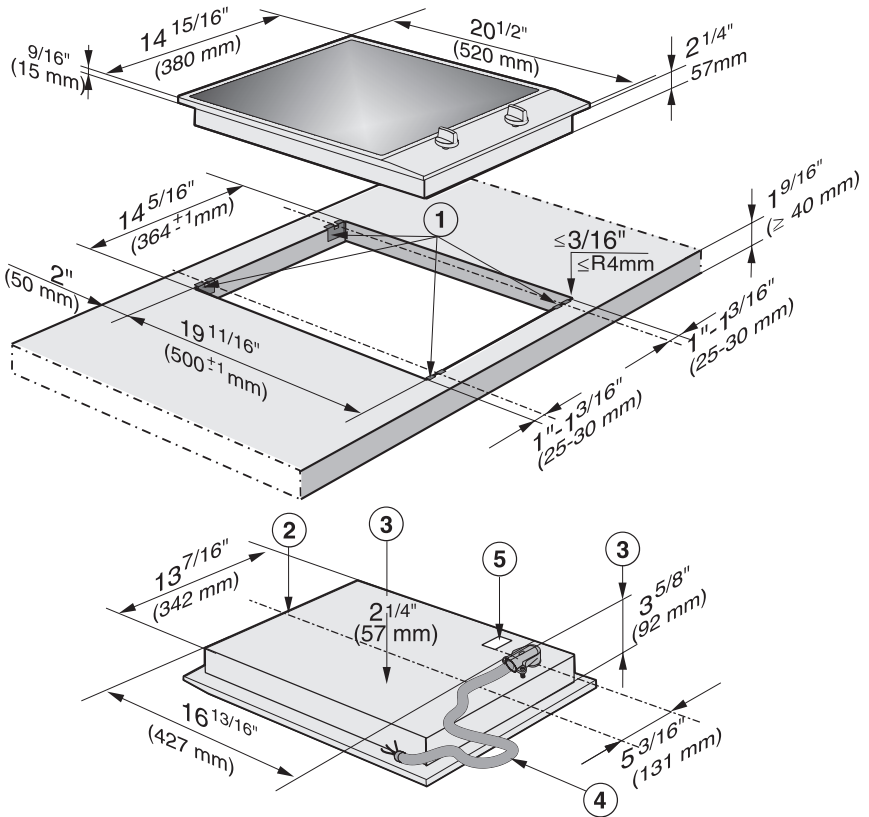

- ① Spring clips
- ② Appliance front
- ③ Installation height
- ④ Power supply box with connection cable, L = $78 \frac{3}{4}''$ (2000 mm)
- ⑤ Rating label

Installation

Cut out

- Make the countertop cut-out for the desired number of appliances. Remember to maintain a **minimum safety distance** from the **back wall**, as well as from any **tall unit or side wall** to the left or right of the combiset.
See also the "IMPORTANT INSTALLATION SAFETY INSTRUCTIONS".
- Seal the cut surfaces with a suitable sealant to avoid swelling caused by moisture. The materials used must be heat resistant.

If during installation the seal around the frame does not sit flush with the countertop in the corners, the corner radius, maximum $\frac{3}{16}$ " (4 mm), can be carefully filed down to fit.

Installation of multiple appliances

When installing more than one combiset appliance, a support bar ② must be installed between the appliances.

Countertop cut-out two appliances

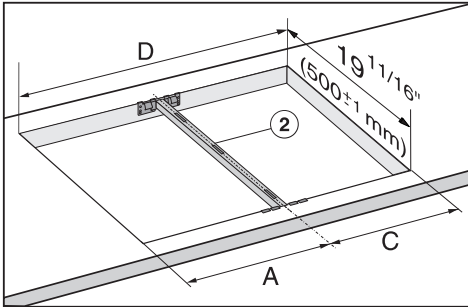

For the installation of **two appliances** the width of the countertop cut-out D is the sum of A and C.

A, B and C = appliance width
 11 5/16", 15" or 22 11/16"
 (288 mm, 380 mm or 576 mm)
minus 5/16" (8 mm) to allow for the overhang

D = width of the countertop cut-out

Countertop cut-out three appliances

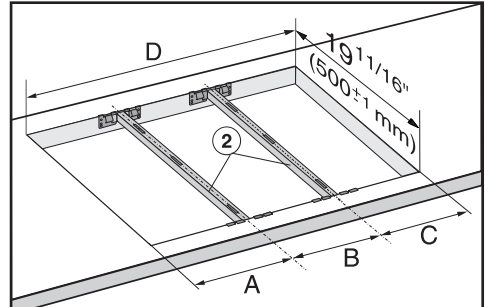

For the installation of **three appliances** the width of the countertop cut-out D is the sum of A and B and C.

If **more than three appliances** are being installed, you will need to add, A, B or C for each additional appliance.

Installation

Sample calculations for a countertop cut-out for three appliances

A appliance width minus 5/16" (8 mm)	B appliance width	C appliance width minus 5/16" (8 mm)	D Countertop cut-out
11" (280 mm)	11 5/16" (288 mm)	11" (280 mm)	33 3/8" (848 mm)
11" (280 mm)	15" (380 mm)	14 5/8" (372 mm)	40 5/8" (1032 mm)
11" (280 mm)	22 11/16" (576 mm)	22 3/8" (568 mm)	56 1/16" (1424 mm)
14 5/8" (372 mm)	11 5/16" (288 mm)	11" (280 mm)	37" (940 mm)
14 5/8" (372 mm)	15" (380 mm)	14 5/8" (372 mm)	44 1/4" (1124 mm)
14 5/8" (372 mm)	22 11/16" (576 mm)	22 3/8" (568 mm)	59 11/16" (1516 mm)
22 3/8" (568 mm)	11 5/16" (288 mm)	11" (280 mm)	44 3/4" (1136 mm)
22 3/8" (568 mm)	15" (380 mm)	14 5/8" (372 mm)	52" (1320 mm)
22 3/8" (568 mm)	-	22 3/8" (568 mm)	44 3/4" (1136 mm)

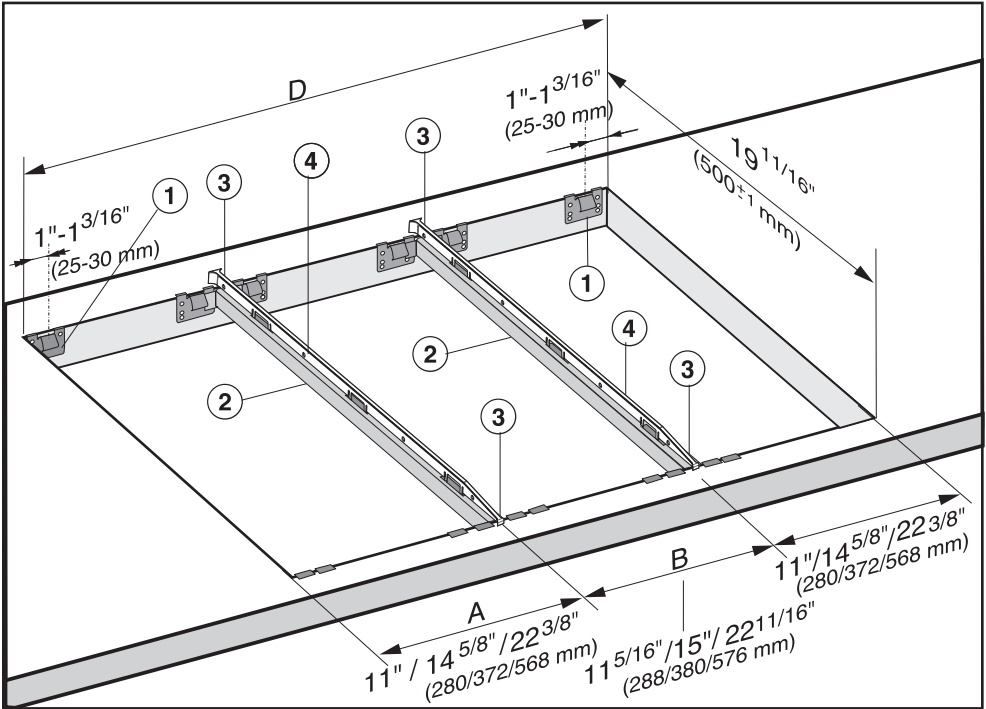

- ① Spring clips
- ② Support bars
- ③ Space between support bar and countertop
- ④ Sealing strip

The illustration represents the attachment of spring clips ① and support bars ② for 3 appliances.

An additional support bar is required for each additional appliance. The position for attachment of an additional support bar depends on the width of appliance **B**.

Installation

Attach the spring clips and support bars

Wood or solid surface countertops

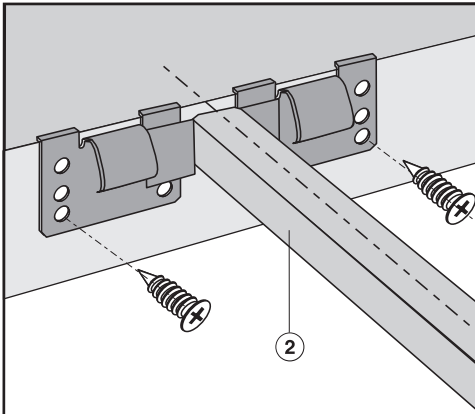
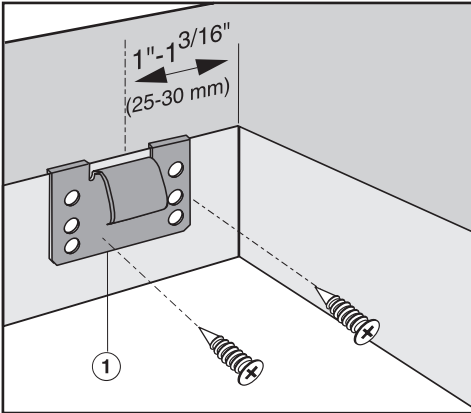

- Place the supplied spring clips ① and the support bars ② at the marked positions as shown above, by laying them on the upper edge of the cut-out and then securing them with the $\frac{1}{8}'' \times 1''$ (3.5 x 25 mm) screws (supplied).

Granite countertop

The screws are not needed for granite countertops.

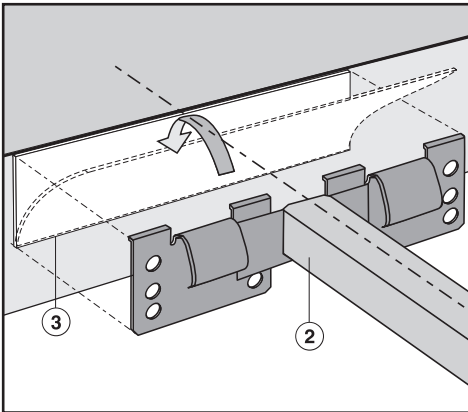
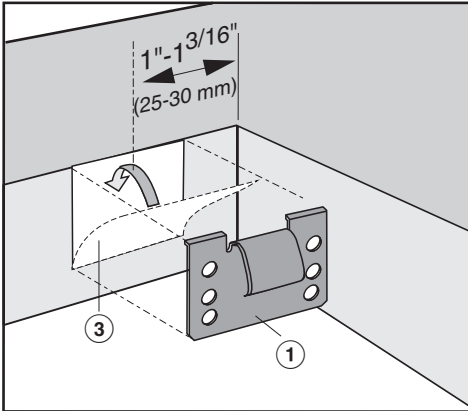

- Position and attach the spring clips ① and support bars ② with strong, double-sided tape ③.

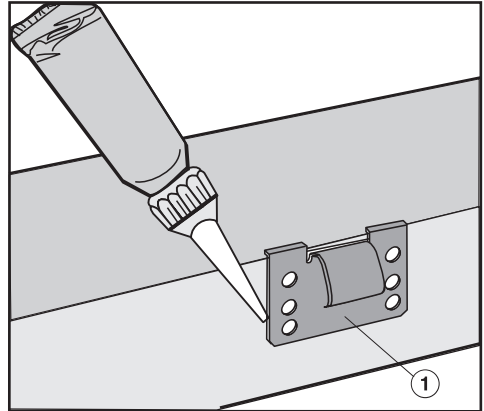

- Coat the edges of the spring clips ①,

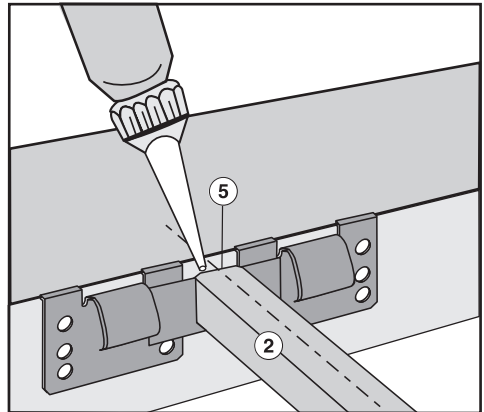

- and the space ⑤ between the support bars ② and the countertop with silicone (supplied).

Installation

Installing the appliance / appliances

- Feed the power cord down through the cut-out.
- Place the front edge of the appliance into the cut-out.
- With a hand on each side of the appliance press down evenly on the edges until it clicks into position. When doing so make sure that the appliance seal sits tightly on the countertop to ensure it is sealed correctly. This is important to ensure an effective seal. **Do not** permanently seal into the countertop.

When installing more than one appliance, a sealing strip must be inserted into the support bar.

- Push the installed appliance to the side until the slots in the support bar are visible.

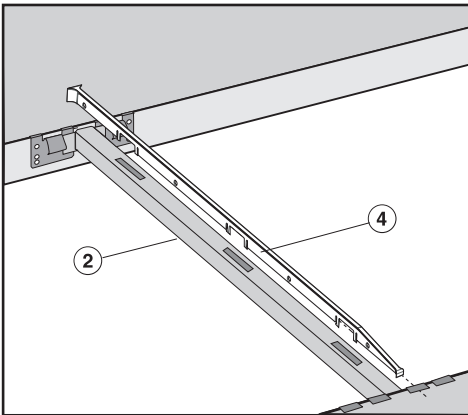

- Insert the sealing strip ④ into the slots in the support bar ②.

- Place the front edge of the next appliance into the cut-out.
- Connect the appliance / appliances to the main power supply (see "Electrical connection").
- Turn the appliance / appliances on and check the function.

The appliance may be lifted out using a special tool.
The appliance can also be pushed up and out from underneath.
Note: push the rear out first.

Sealing

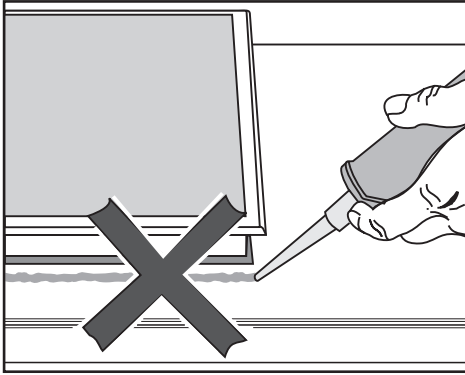

The appliance must not be permanently sealed into the countertop when installed. The sealing strip under the edge of the appliance provides a sufficient seal for the countertop.

If the appliance is sealed into position, the countertop or appliance could be damaged if it needs to be removed for maintenance or service.

Tiled surfaces

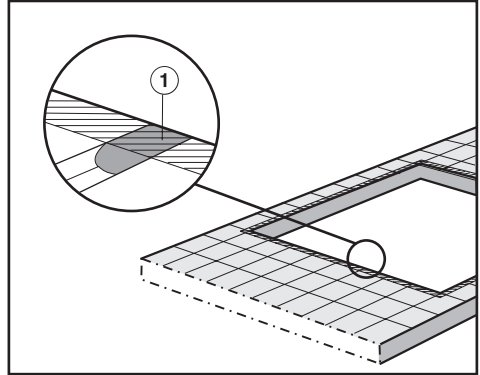

The grouting ① and shaded area under the appliance frame must be flat and even so that the frame will lie evenly and the sealing strip under the edge of the upper part of the appliance can provide an adequate seal against the countertop.

Electrical connection

 **CAUTION:** Before installation or servicing, disconnect the power supply by either removing the fuse, shutting off the main power or manually "tripping" the circuit breaker.

Installation work and repairs should only be performed by a qualified technician in accordance with all applicable codes and standards. Repairs and service by unqualified persons could be dangerous.

Before connecting the appliance to the power supply, make sure that the voltage and frequency listed on the rating label correspond with the household electrical supply. This data must correspond to prevent appliance damage. Consult an electrician if in doubt.

Only operate the appliance after it has been installed into the countertop.

Installer:
Please leave these instructions with the consumer.

Power supply

- Be sure your electrical supply matches the rating label.

The rating label is located on the underside of the appliance.

The combiset is equipped with a power cord encasing 3 wires ready for connection to a grounded power supply.

They must be connected to a dedicated line through the use of an approved junction box.

Black : connect to L1 (hot)

Red: connect to L2 (hot)

Green: connect to GND (ground):

208 V, 60 Hz, 20 A fuse rating

240 V, 60 Hz, 15 A fuse rating

Be sure the power outlet is accessible after installation.

For further information, see the wiring diagram provided with the appliance.

 **WARNING:**
THIS APPLIANCE MUST BE GROUNDED!

Help protect our environment

Disposal of packing materials

The cardboard box and packing materials are biodegradable and recyclable. Please recycle.

Ensure that any plastic wrappings, bags, etc. are disposed of safely and kept out of the reach of children.

Danger of suffocation!

Disposal of an old appliance

Old appliances contain materials that can be recycled. Please contact your local recycling authority about the possibility of recycling these materials.

Before discarding an old appliance disconnect it from the electrical supply and cut off the power cord to prevent it from becoming a hazard.

**Please have the model and serial number
of your appliance available before
contacting Technical Service.**



**U.S.A.
Miele, Inc.**

National Headquarters

9 Independence Way
Princeton, NJ 08540
Phone: 800-843-7231
609-419-9898
Fax: 609-419-4298
www.miele.com

**Technical Service & Support
Nationwide**

Phone: 800-999-1360
Fax: 888-586-8056
TechnicalService@mieleusa.com

**Canada
Miele Limited**

Headquarters and Showroom

161 Four Valley Drive
Vaughan, ON L4K 4V8
Phone: 800-643-5381
905-660-9936
Fax: 905-532-2290
www.miele.ca
professional@miele.ca
(commercial enquiries)

MieleCare National Service

Phone: 800-565-6435
905-532-2272
Fax: 905-532-2292
customercare@miele.ca
(general and technical enquiries)