



PERFECT HEAT.™

CS COOKTOP SERIES

Installation Guide



MODELS:

CS-366

CS-364GL

CS-364G

CS-484GG

CS-486GL

CS-486GD

CS-485GD



A MESSAGE TO OUR CUSTOMERS

Thank you for selecting this DCS CS Cooktop. Because of this appliance's unique features we have developed this Installation Guide. It contains valuable information on how to properly install your new appliance for years of safe and enjoyable cooking.

For your convenience, product questions can be answered by a DCS Customer Service Representative by phone: 1-888-281-5698, Fax: 714-372-7004, email: support@dcsappliances.com, or by mail:

DCS
Attention: Customer Service
800 Skylab Road
Huntington Beach, CA 92647
www.dcsappliances.com

WARNING

If the information in this manual is not followed exactly, a fire or explosion may result causing property damage, personal injury or death.

PRECAUTION

Do not store or use gasoline or other flammable vapors and liquids in the vicinity of this or any other appliance.

FOR YOUR SAFETY

IF YOU SMELL GAS:

- *Do not try to light any appliance.*
- *Do not touch any electrical switch; do not use any phone in your building.*
- *Immediately call your gas supplier from a neighbor's phone. Follow the gas supplier's instructions.*
- *If you cannot reach your gas supplier, call the fire department.*

- *Installation and service must be performed by a qualified installer, service agency or the gas supplier.*

PLEASE RETAIN THIS MANUAL FOR FUTURE REFERENCE.

TABLE OF CONTENTS

INTRODUCTION	3
MODELS	4
PLANNING THE INSTALLATION	5
UNPACKING AND HANDLING	6
VENTILATION REQUIREMENTS	7
CABINET PREPARATION	8-10
BACKGUARD INSTALLATION	11
ELECTRICAL / GAS CONNECTIONS	12
HOOK-UP TO GAS SUPPLY	13
TEST AND ADJUSTMENTS	14
INSTALLER FINAL CHECKLIST	15
WIRING DIAGRAMS / SCHEMATICS	16-19
CS Cooktop 36" / 48" Wiring Diagram	16
CS Cooktop 36" / 48" Wiring Schematic	17
CS Cooktop 485 Wiring Diagram	18
CS Cooktop 485 Wiring Schematic	19
HOW TO OBTAIN SERVICE	20
WARRANTY	21

INTRODUCTION

The DCS Professional CS Cooktops feature a large number of features varying with each model . All models feature a minimum of 4 surface burners, with the option of up to 6 surface burners on all models. All of the 48" and 36" Cooktops feature the possibility of various grill and griddle combinations. All cooktop models require the installation of one of the two offered backguards, if installed with less than 12" to combustible material. See page 10.

IMPORTANT INSTALLATION INFORMATION

The cooktops are tested in accordance with ANSI Z21.1 Standard for Household Cooking Gas Appliances. These cooktops must be installed in conjunction with a suitable overhead vent hood. (See Step 2 for ventilation requirements). Due to the professional high heat capacity of this unit, particular attention should be paid to the hood and duct work installation to ensure it meets local building codes. To eliminate risk of burns or fire by reaching over heated surface units, cabinet storage located above the surface units should be avoided. Check local building codes for the proper method of cooktop installation. Local codes vary. Installation, electrical connections, and grounding must comply with all applicable codes. In the absence of local codes, the cooktop should be installed accordance with the National Fuel Gas Code ANSI Z223.1-1988 and National Electrical Code ANSI / NFPA 70-1990. Be sure that the unit being installed is set up for the kind of gas being used. The gas cooktop is shipped from the factory set and adjusted for natural gas or LP (propane), depending on the specific model ordered. **Verify that the cooktop is compatible with gas supply at the installation site before proceeding further.** Return cooktop to dealer if unit is not set for site gas supply.

MODELS

48" CS COOKTOP MODELS

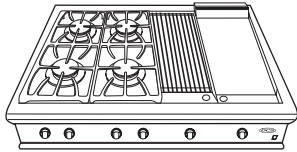

CS-484GG

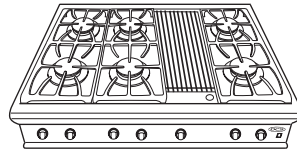

CS-486GL

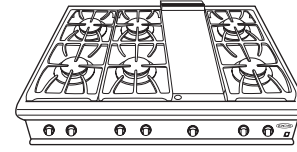

CS-486GD

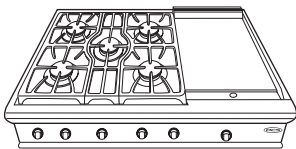

CS-485GD

36" CS COOKTOP MODELS

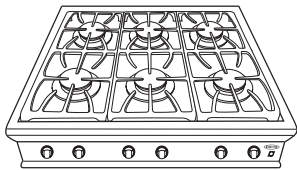

RGS-366

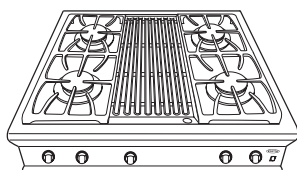

RGS-364GL

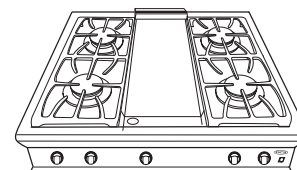

RGS-364GD

PLANNING THE INSTALLATION

RECOMMENDED INSTALLATION INSTRUCTION

(If installing a full backguard with the cooktop)

- A) Vent Hood
 - B) Backguard System
 - C) Cooktop
- 1) Locate cooktop according to cooktop installation instructions.
 - 2) Measure distance from counter surface to top of trim on cooktop adding 1/8" for backguard clearance.
 - 3) Transfer this measurement to the wall. This will mark the bottom of your backguard.
 - 4) From this line measure 30 1/16" up wall to mark top of 30" backguard. This is the minimum height that the bottom of your vent hood can be installed.
 - 6) Follow vent hood manufacturer's installation instructions to install vent hood.
 - 7) Follow backguard installation instructions to install backguard.
 - 8) Connect gas and electric connections and slide cooktop into position.

UNPACKING AND HANDLING

STEP 1: MOVING AND PLACING THE COOKTOP

NOTE: If a solid side cabinet wall exists on one or both sides, you will need to notch the front corner of the cabinet to match the counter top notch and to provide clearance for the cooktop front (see page 8).

CAUTION:

Proper equipment and adequate manpower must be used in moving the cooktop to avoid personal injury or damage to the unit

ANCHORING THE COOKTOP

The cooktops have a shipping weight of approximately 228 pounds (36" models) and 324 pounds (48" models). After removal of packing materials, it is recommended that the grates and drip pan (below knobs) be removed to facilitate handling. This will reduce the weight to about 150 pounds.

- DO NOT REMOVE THE GRILL OR GRIDDLE ASSEMBLIES.

It may be necessary to remove the cooktop knobs to pass through some doorways. With the knobs removed a 29-3/8" wide opening is required. Remove the outer carton and packing material from the shipping base. The cooktop is held to the skid by four straps. After removing the straps, the cooktop must be lifted and removed from the skid.

The professional cooktop should be moved close to its final location. Electric and gas connections should be made (steps 5 & 6 pgs. 12 & 13) and the backguard installed (as required, step 4 pg. 11) before the cooktop is placed in its final position. The grill and griddle sections are fastened in place at the front with screws. They are designed to be stationary and not meant to be removed for cleaning. The griddle has two leveling screws beneath the rear flue cover which can be used to adjust the griddle to the desired slope. The center screw is for shipping and should be removed.

- Due to the weight of the cooktop, along with a built-in side frame gasket that is meant to rest and create a seal on the counter top once installed, it is not necessary to anchor the unit to the counter.

VENTILATION REQUIREMENTS

STEP 2:

A suitable exhaust hood must be installed above the cooktop. The following chart indicates the minimum blower capacity recommended for hood ventilation.

VENTILATION UNIT	STANDARD COUNTER INSTALLATION RECOMMENDATIONS	ISLAND INSTALLATION RECOMMENDATIONS
HOOD	(24" Deep x Unit Width)	(30" Deep x 36" at Bottom)
BLOWER	*48" COOKTOP 800-1200 CFM	800-1200 CFM
	**36" COOKTOP 600-800 CFM	600-1200 CFM

* When installing a unit featuring a grill, select a blower on the high end of recommendation.

** For all 36" Cooktop GL models a 1200 CFM ventilation unit is required.

CAUTION:

Ventilation hoods and blowers are designed for use with single wall ducting. However, some local building codes or inspectors may require double wall ducting. Consult local building codes and/or local agencies, before starting, to ensure that hood and duct installation will meet local requirements.

Hood blower speeds should be variable to reduce noise and loss of heated or air conditioned household air when maximum ventilation is not required. Normally, the maximum blower speed is only required when using the grill. For best smoke elimination, the lower edge of the hood should be installed a minimum of 30" to a maximum of 36" above the cooktop cooking surface, (step 3 pg. 8). If the hood contains any combustible materials (i.e. a wood covering) it must be a minimum of 36" above the cooking surface. Due to a high volume of ventilation air, a source of outside replacement air is recommended. This is particularly important for tightly sealed and insulated homes. A reputable heating and ventilating contractor should be consulted.

CABINET PREPARATION

STEP 3:

- 1) To ensure professional results, the cabinet and countertop openings should be prepared by a qualified cabinet worker. We recommend having the cooktop available before cutting the opening for more precise dimension verification.
- 2) The clearances shown in Fig. 5 pg. 10 are required for all types of backguard installations.
- 3) The cooktop is designed to hang from the countertop from its side flanges. The countertop, however, must be strong enough to support this heavy cooktop. It may be necessary to add a supporting cleat along each side or other form of support such as a 2" x 4" corner brace on each side, or a deck to set the cooktop on. See Fig.1.
- 4) The cooktop can be installed in various positions with the front either flush or projecting, depending on the countertop depth. See Fig. 2 & Fig. 4 (cooktop side view).
- 5) Establish the centerline of the desired cooktop location. It should be the same as the center of the overhead ventilation hood.

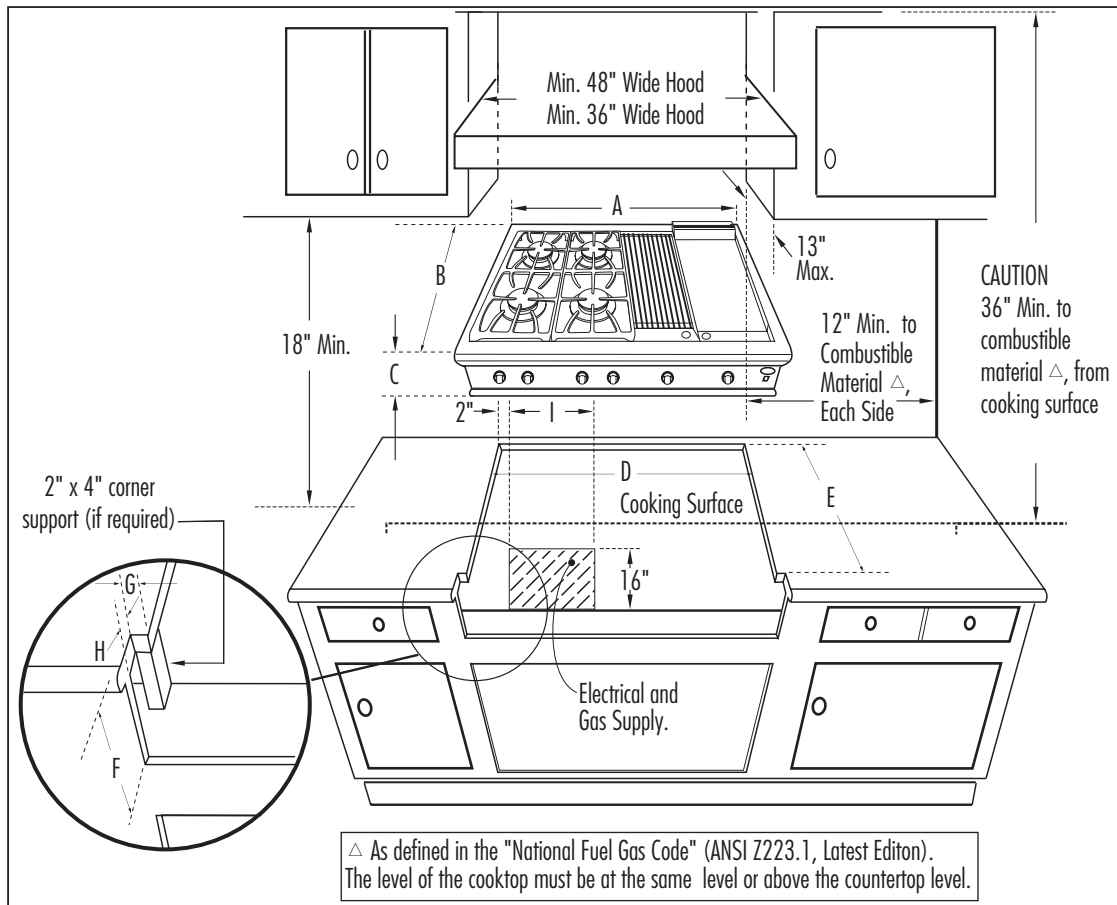

Fig. 1 CS Cooktop Models

	A	B	C	D	E	F	G	H
CS 48 Models	47-7/8"	26-1/2"	8-7/16"	46-5/16"	22-3/4"	8"	7/8"	0-2-1/2"
CS 36 Models	35-7/8"	26-1/2"	8-7/16"	34-15/16"	22-3/4"	8"	1/2"	0-2-1/2"

CABINET PREPARATION

STEP 3: (CONTINUED)

6) Cut the openings for the following installation:

- Standard counter top installation, see Fig. 5A
- Deep counter or island installation, see Fig. 5B

NOTE: *If the deck is used, the sides or bottom of the cutout may be solid combustible or non-combustible material. If the bottom is solid, provide a 6" x 6" cutout in the left rear corner for the gas inlet and power cord clearance.*

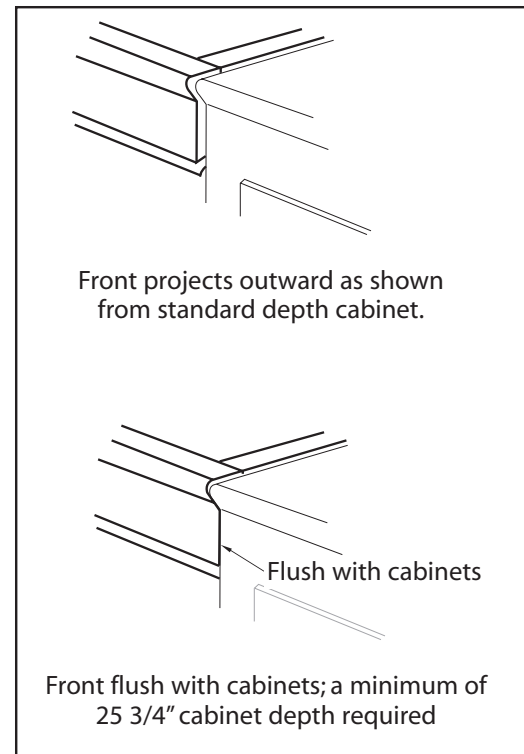

Fig. 2

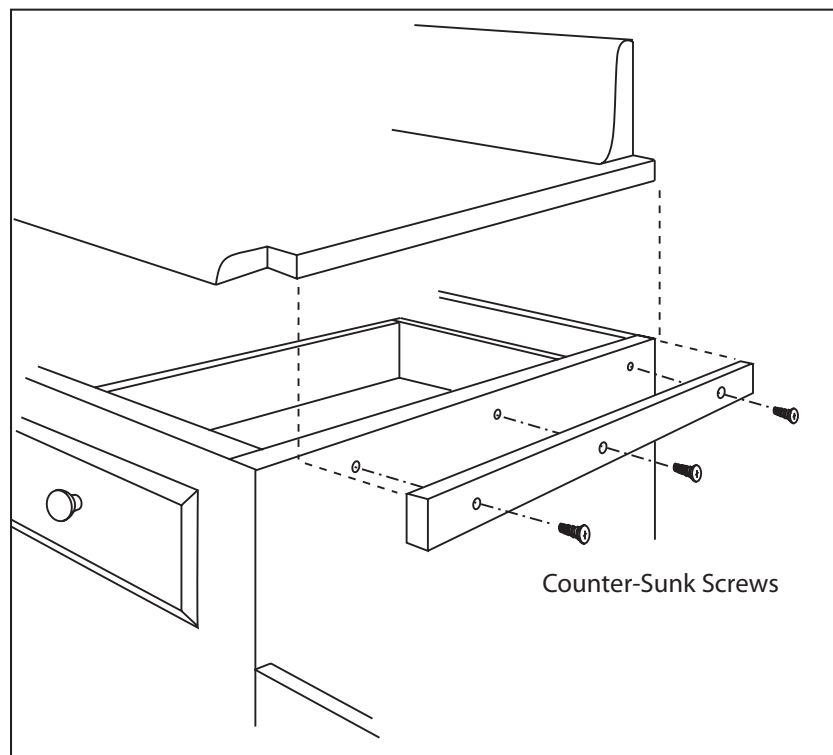

Fig. 3

CABINET PREPARATION

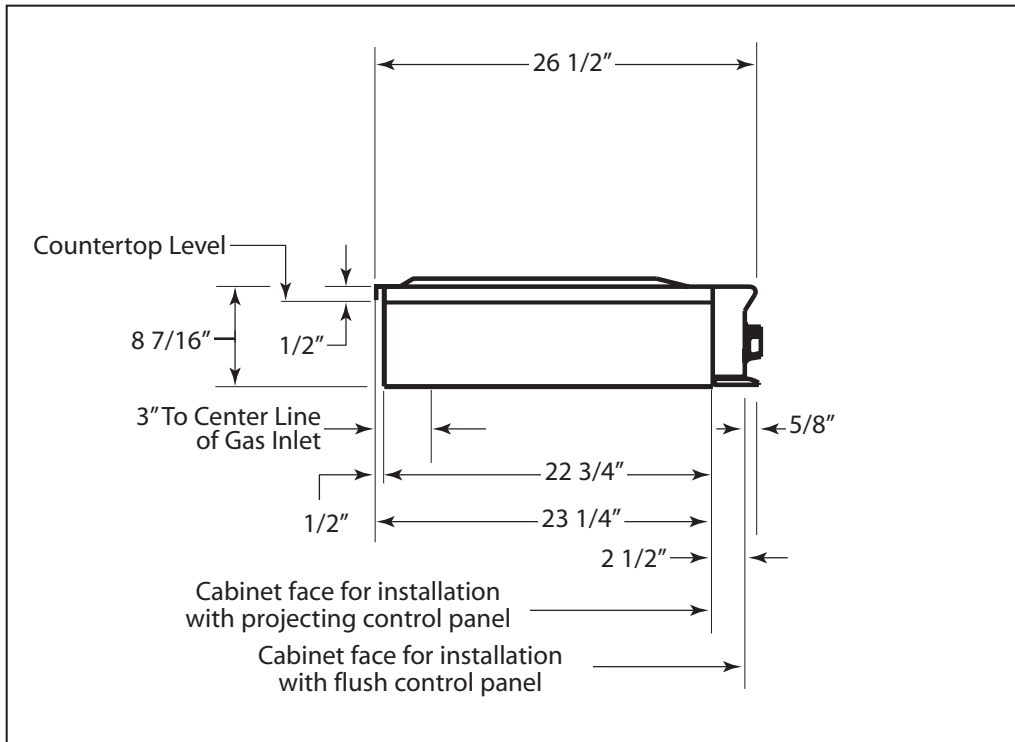

Fig. 4

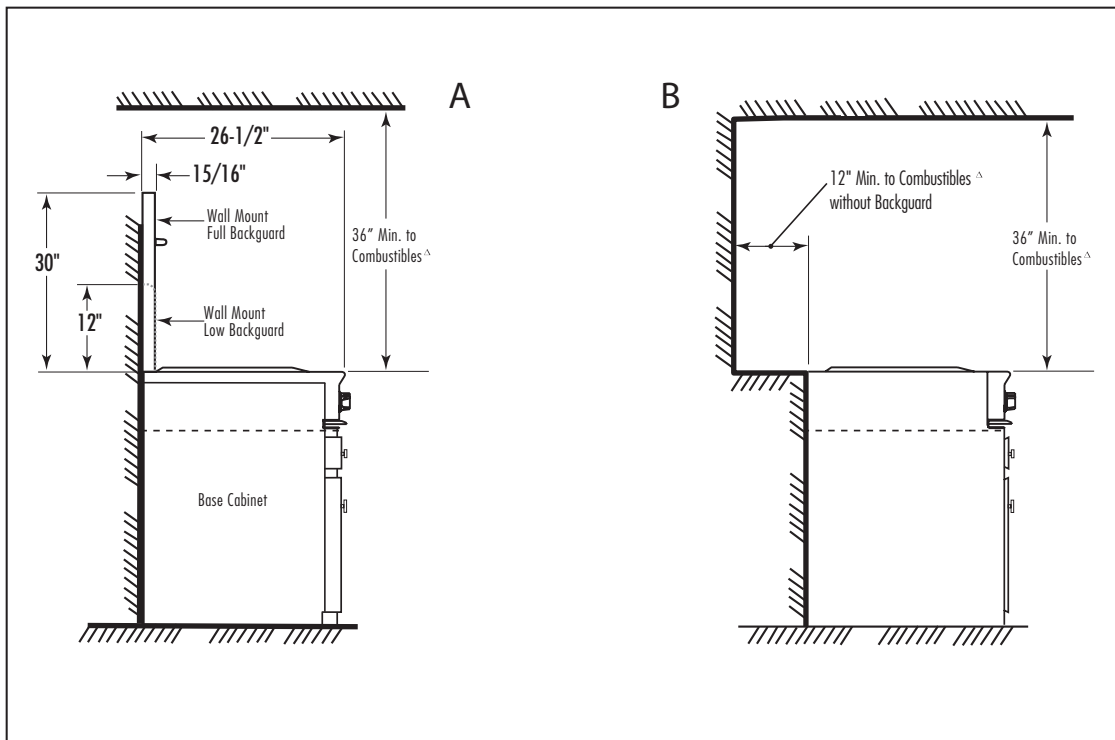

Fig. 5

BACKGUARD INSTALLATION

STEP 4:

BACKGUARD KITS:

The backguard is located as shown in Fig. 6. Secure the backguard to the wall behind the cooktop.

Specific instructions for installation of the full backguard or low backguard can be found packaged with the backguard. See also page 5.

The backguard must be installed when there is less than a 12" clearance between combustibles and the back of the cooktop (above the cooking surface, see Fig. 5, page10).

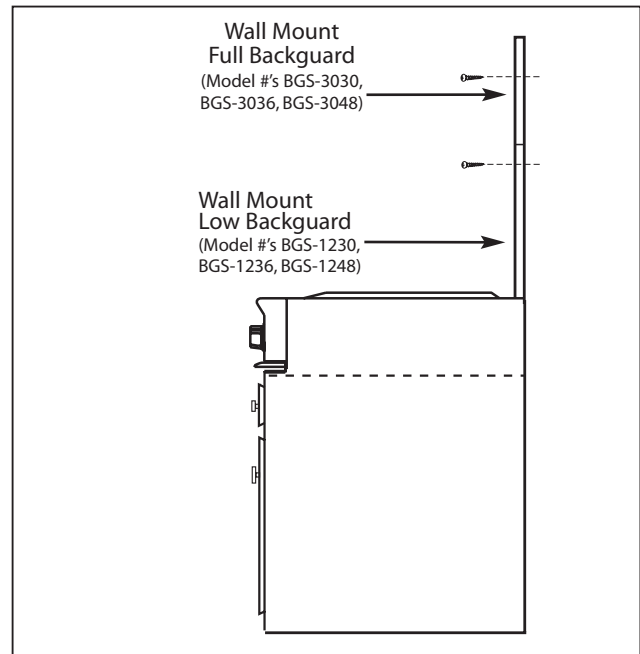

Fig. 6

ELECTRICAL / GAS CONNECTIONS

STEP 5: ELECTRICAL CONNECTIONS

Power requirements Cooktop:

- 120 VAC, 60 Hz., single phase 7 Amp.
- CS-48: 15 Amp. Max.
- CS-36: 15 Amp. Max. (use 15 Amp. circuit)

Always disconnect electric supply cord from the wall outlet or service disconnect before servicing this appliance. Observe all governing codes and ordinances when grounding, in absence of which, observe National Electrical Code ANSI / NFPA No. 70-1990.

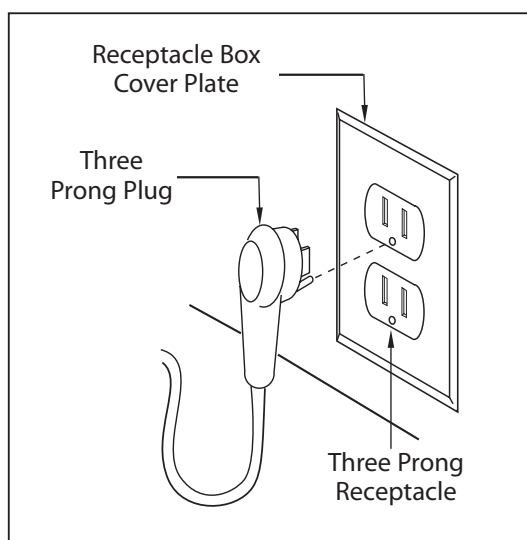

Fig. 7

RECOMMENDED GROUNDING METHOD

This appliance is factory equipped with a power supply cord with a three-prong grounding plug (with polarized parallel blades). It must be plugged into a mating grounding type receptacle, connected to a correctly polarized 120 Volt circuit. If the circuit does not have a grounding type receptacle, it is the responsibility and obligation of the installer to have the existing receptacle changed to a properly grounded and polarized receptacle in accordance with all applicable local codes and ordinances by a qualified electrician. In the absence of local codes and ordinances, the receptacle replacement shall be in accordance with the National Electrical Code.

- The third prong should not, under ANY circumstances, be cut or removed.

GAS REQUIREMENTS

Verify the type of gas supplied to the location. The cooktop are shipped from the factory set up and adjusted for natural gas or LP (propane), depending on specific model ordered. The unit cannot be converted.

NATURAL GAS

- Connection: 1/2" N.P.T., Minimum 5/8" dia. flex line. ■ Pressure: 6" to 14" W.C.

LP GAS

- Connection: 1/2" N.P.T., Minimum 5/8 dia. flex line. ■ Pressure: 11" to 14" W.C.
- A regulator is required at the LP source to provide a maximum of 14" W.C. to the cooktop regulator.

HOOK-UP TO GAS SUPPLY

STEP 6:

HOOK-UP

A manual valve must be installed external to the appliance, in an accessible location from the front for the purpose of shutting off the gas supply. Make sure the gas supply is turned off at the wall valve before connecting the appliance. The gas supply connections should be made by a qualified technician and in accordance with local codes or ordinances. In the absence of a local code, the installation must conform to the National Fuel Gas Code ANSI Z223.1-1988, latest edition.

To prepare the unit for connection to the gas supply, thread the supplied 1/2" pipe nipple into the elbow on the end of the manifold. The elbow is located inside the chassis of the unit, on the end of the manifold, facing down. See fig. 9. It is accessible through the square cutout in the left rear corner of the chassis bottom. Connect the outlet of the regulator to the exposed end of the nipple, connect the flex line from the gas supply to the inlet side of the regulator.

NOTE: *The arrow on the regulator indicating direction of gas flow should be pointing towards the unit. The flex line for the gas supply must be metal and be approved by an approved certifying agency (AGA, CGA, or UL.). Never use a hose made of rubber or other synthetic material, as the heat may cause the hose to melt and develop leaks.*

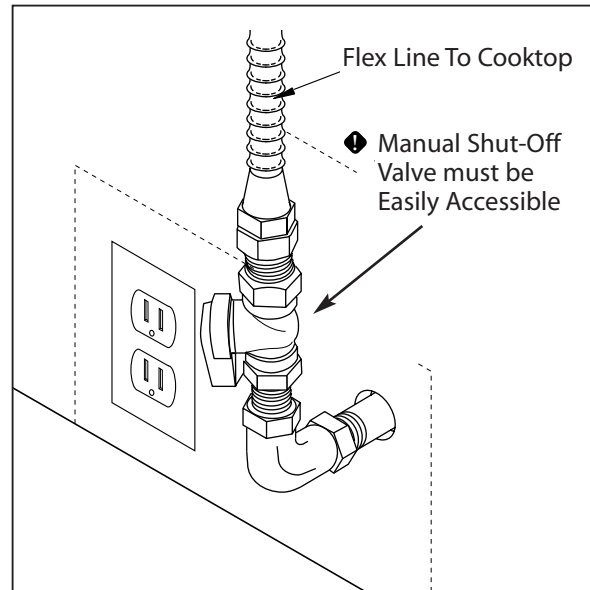

Fig. 8

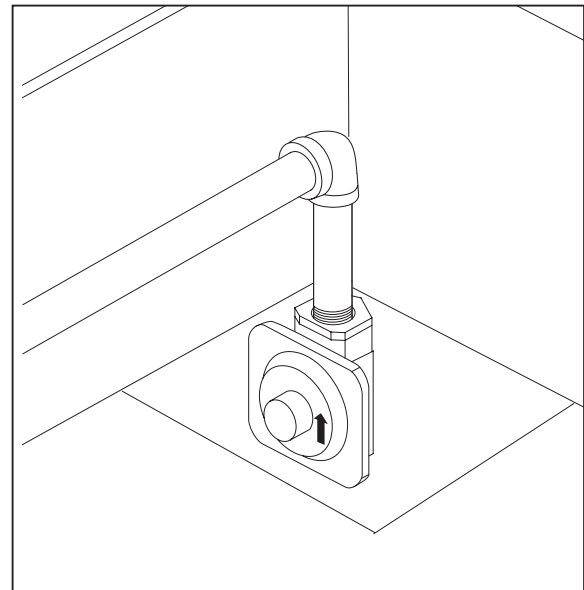

Fig. 9

CAUTION:

The appliance must be isolated from the building's gas supply piping system by closing its individual manual shut-off valve during any pressure testing of the gas supply piping system at test pressures equal to or less than 1/2 psig (3.5kPa.). The appliance and its individual shut-off valve must be disconnected from the gas supply piping system during any pressure testing of the system at the test pressures in excess of 1/2 psig (3.5kPa.). When checking the manifold gas pressure, the inlet pressure to the regulator should be at least 7.0" W.C. for natural gas or 12.0" for LP.

TEST AND ADJUSTMENTS

STEP 7:

CAUTION:

For warranty coverage, DCS requires that burner adjustments be made by a qualified technician at the time of installation. Extreme care should be used when adjustments are made after installation. Improper or lack of adjustments will void your warranty.

AIR SHUTTER ADJUSTMENT (Griddle or Grill only)

Check for the proper burner flame characteristics and adjust air shutters if necessary (fig. 10). Each air shutter is individually tested and adjusted prior to shipment. Normally adjustment is not required, however, vibration during transit, or variations in the local gas supply may make minor adjustments necessary. Burner flames should be blue and stable with no yellow tips, excessive noise or lifting of the flame from the burner. If any of these conditions exist, check that the air shutter or burner ports are not blocked. If this condition persists, adjust the air shutter as required. If the flame is too yellow, indicating insufficient air, adjust the shutter counterclockwise to increase air inlet. If the flame is noisy or tends to lift away from the burner, indicating too much air, turn the shutter clockwise to reduce air. The griddle flames should be 1-1/2" to 2". The grill burner flames should be 3/8" to 5/8" (fig. 10).

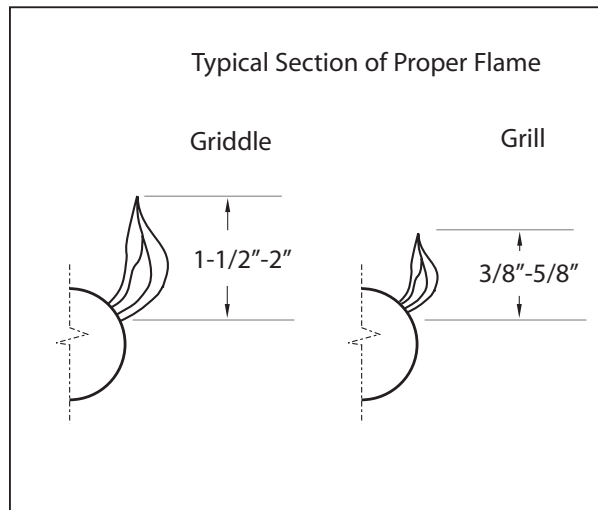

Fig. 10

SURFACE BURNERS

The surface burners are not adjustable. Proper operation is achieved when the correct orifices for gas supply are installed at the factory, based on model ordered.

- If the surface burner does not ignite, check the spark igniter by listening for a clicking sound. If you do not hear the igniter click, turn off the burner. Check for a tripped circuit breaker, blown fuse, or poor wire connection to the igniter.

TO CLEAN EXTERIOR SURFACES

The stainless steel surfaces may be cleaned by wiping with a damp soapy cloth. Any mild glass cleaner will remove fingerprints and smears. Do not use steel wool as it will scratch this surface. Small scratches may be removed by lightly sanding with the grain using 120 grit paper.

INSTALLER FINAL CHECKLIST

GENERAL

- Placement of unit.
- Specified clearance maintained to cabinet surfaces.
- Unit Level - front to back, side to side.
- All packaging material and tie straps removed, drip pans clean and empty.
- Backguard attached if there is less than 12" clearance above the cooking surface to combustibles behind unit.
- Radiant tray placed in grill unit (if equipped). The two grill racks in place.

ELECTRICAL

- Receptacle with 15 ampere over-current protection is provided for service cord connection.
- Adequate ground connection.

GAS SUPPLY

- Connection: 1/2 NPT with a minimum 5/8" diameter metal flex line.
- Site gas supply is compatible with cooktop model, & sufficient pressure is available (see gas requirements pg. 12).
- Manual gas shut-off valve installed in an accessible location.
- Unit tested and free of gas leaks.

OPERATION

- All internal packing materials removed. Check below grate, pans and drip drawers.
- Grill compartment seated and does not rock (not all models).
- Bezels centered on burner knobs and knobs turn freely.
- Each burner lights satisfactorily, both individually and with other burners.
- Flame adjustment made on air shutter of griddle, or grill burner, (figs. 10).
- Griddle is level and does not rock (not all models).
- Drip trays are properly in place and pull out freely (Not all models).
- Burner grates correctly positioned, level, and do not rock.

CS 36" / 48" WIRING DIAGRAM

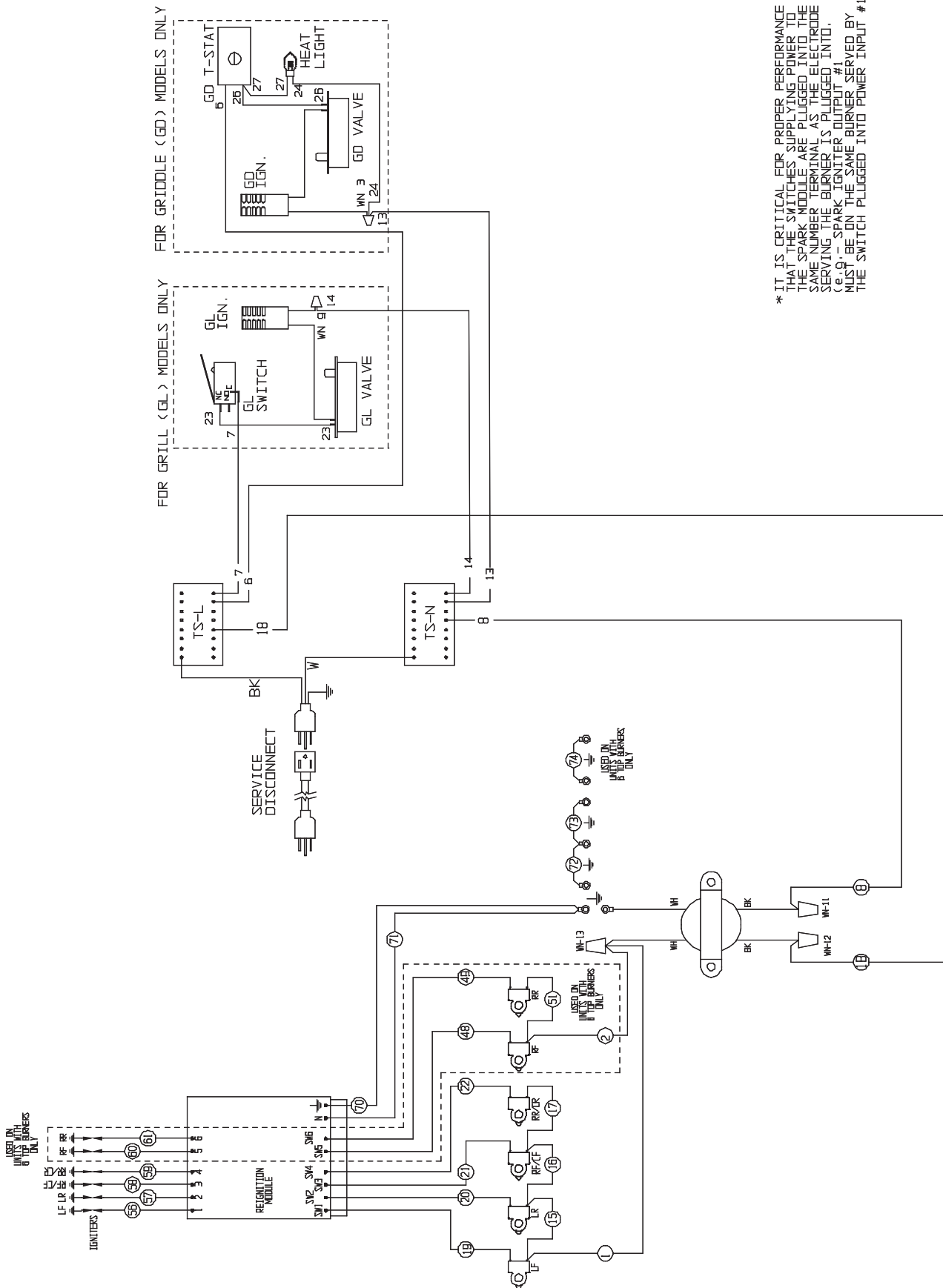

* IT IS CRITICAL FOR PROPER PERFORMANCE THAT THE SWITCHES SUPPLYING POWER TO THE SPARK MODULE ARE PLUGGED INTO THE SAME NUMBER TERMINAL AS THE ELECTRODE SERVING THE BURNER IS PLUGGED INTO. (e.g. - SPARK IGNITER OUTPUT #1 MUST BE ON THE SAME BURNER SERVED BY THE SWITCH PLUGGED INTO POWER INPUT #1).

CS 36" / 48" SCHEMATIC

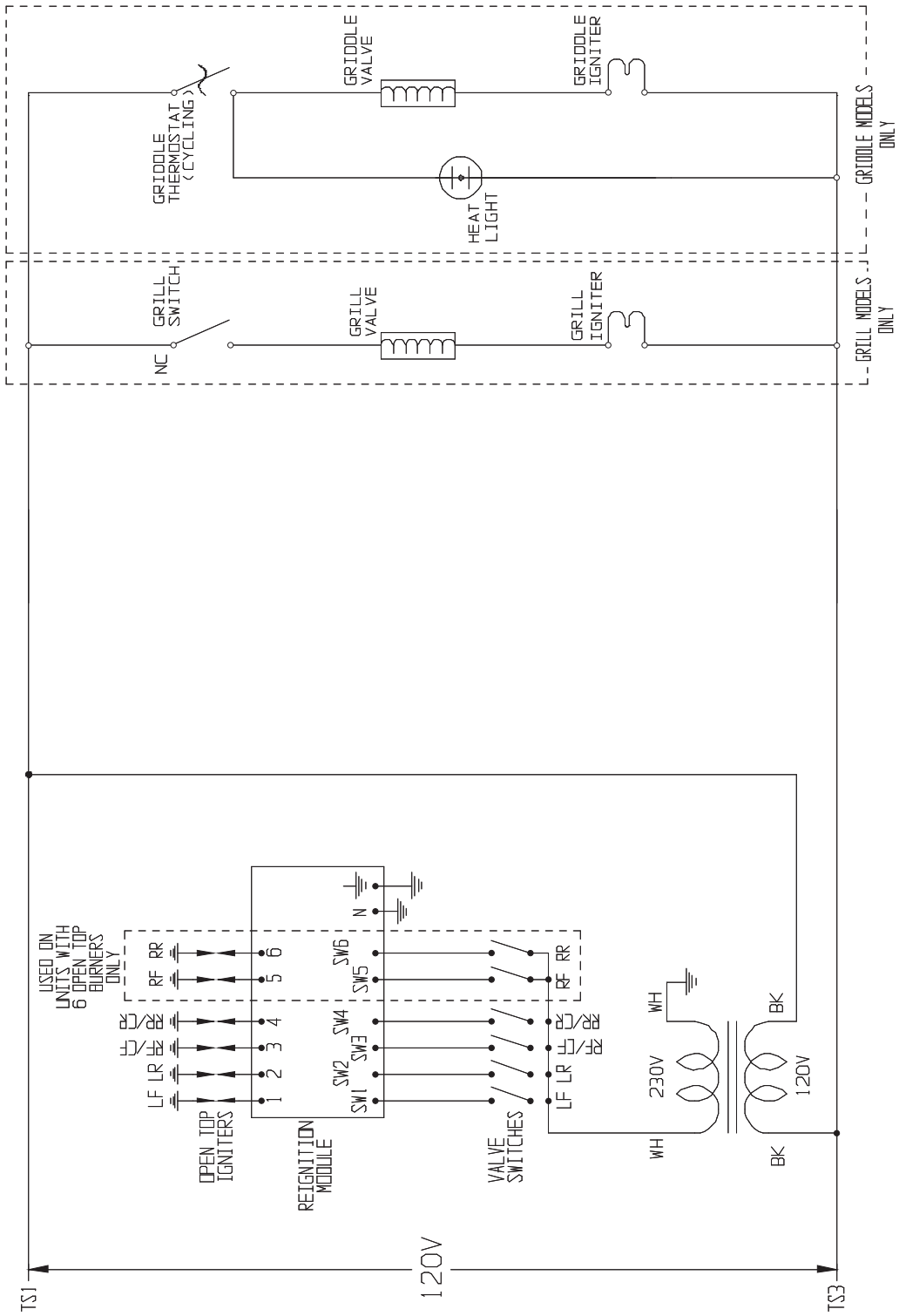

CS 485 WIRING DIAGRAM

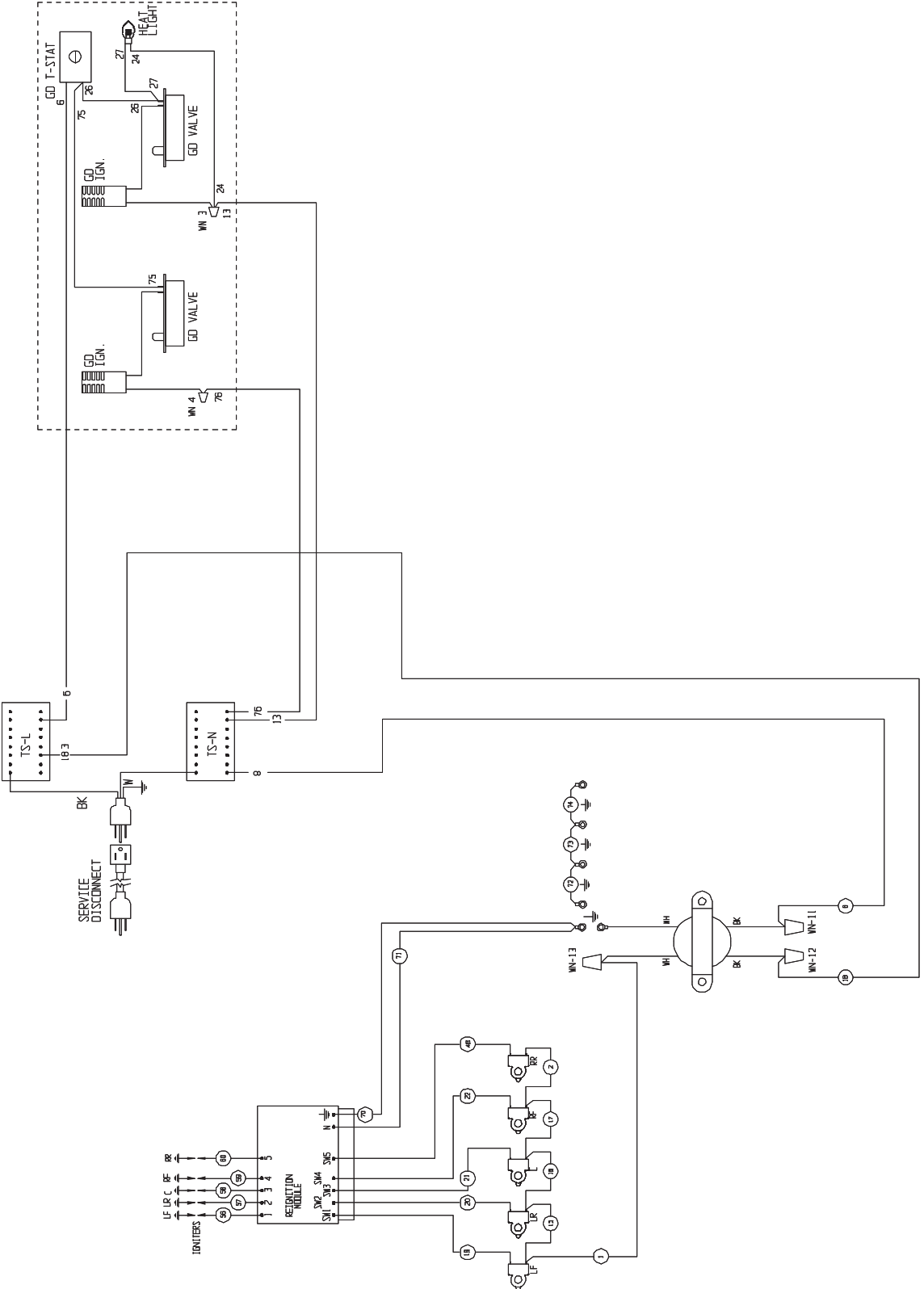

CS 485 WIRING SCHEMATIC

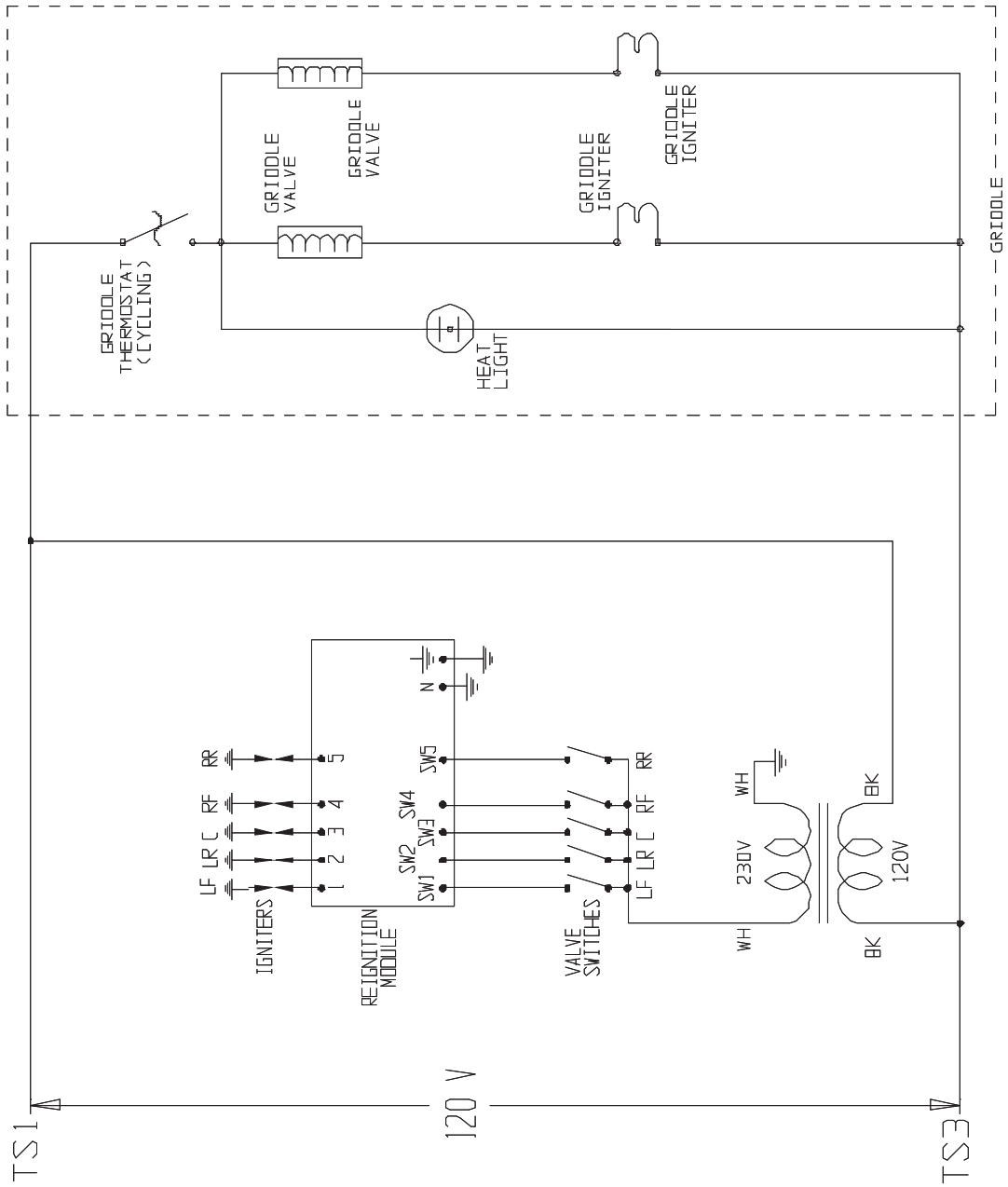

HOW TO OBTAIN SERVICE

For warranty service, contact DCS Customer Service at (888) 281-5698. Before you call, please have the following information ready:

- Model Number
- Serial Number
- Date of installation
- A brief description of the problem

Your satisfaction is of the utmost importance to us. If a problem cannot be resolved to your satisfaction, please write or fax us at:

Write:

DCS
Attention: Consumer Relations
5800 Skylab Road
Huntington Beach, CA 92647

Fax us at: (714) 372-7004

email: support@dcsappliances.com

BEFORE YOU CALL FOR SERVICE:

- 1) Is the circuit breaker tripped or the fuse blown?
- 2) Is there a power outage in the area?

WARRANTY

Length of Warranty:

One (1) Year Full parts and Labor Covers the entire product.

Five (5) Year Surface burners.

Ten (10) Year Limited Cooktop grates.

DCS Will Pay For

All repair labor and parts found to be defective due to materials or workmanship for one full year “IN HOME” warranty during the first year of ownership. This does not apply if the unit was subjected to other than normal household use. Service must be provided by Authorized Factory Agent during normal working hours. No charges will be made for repair or replacement at the location of initial installation or factory for parts returned pre-paid, through the dealer and claimed within the warranty period, and found by DCS to be defective.

Replacement will be F.O.B. DCS, and DCS will not be liable for any transportation costs, labor costs, or export duties. This warranty shall not apply, nor can we assume responsibility for damage that might result from failure to follow manufactures instructions or local codes, where the appliance has been tampered with or altered in anyway or which, in our judgement, has been subjected to misuse, negligence, or accident. Implied warranty shall not extend beyond the duration of this written warranty. This warranty is in lieu of all warranties expressed or implied and all other obligations or liability in connection with the sale of this appliance.

DCS Will Not Pay For

- Installation or start-up.
- Shipping damage.
- Service by an unauthorized agency.
- Damage or repairs due to service by an unauthorized agency or the use of unauthorized parts.
- Service during other than normal working hours.
- Improper installation, such as improper hook-up, etc.
- Service visits to teach you how to use the appliance; correct the installation; reset circuit breakers or replace home fuses.
- Repairs due to other than normal household use.
- Damage caused from accident, abuse, alteration, misuse, incorrect installation or installation not in accordance with local codes.
- Units installed in non-residential application such as day care centers, bed and breakfast centers, churches, nursing homes, restaurants, hotels, schools, etc.

This warranty applies to appliances used in residential applications; it does not cover their use in commercial situations. This warranty is for products purchased and retained in the 50 states of the U.S.A., the District of Columbia and Canada. This warranty applies even if you should move during the warranty period. Should the appliance be sold by the original purchaser during the warranty period, the new owner continues to be protected until the expiration date of the original purchaser’s warranty period. This warranty gives you specific legal rights. You may also have other rights which vary from state to state.

NOTES



PERFECT HEAT.™

5800 Skylab Road, Huntington Beach, CA 92647
Tel: 714.372.7000 • Fax: 714.372.7001
Customer Service: (888) 281-5698
www.dcsappliances.com

As product improvement is an ongoing process at DCS, we reserve the right to change specifications or design without notice.

P/N 17526 Rev. B
Litho in USA 08/2002