

Professional Sealed Side Burner Specs

Gas Requirements:

NATURAL

- 1/2" NPT male with 3/8" flare adapter
- Operating Pressure: 4" W.C.
- Supply Pressure: 5" to 14" W.C.

PROPANE

- 1/2" NPT male with 3/8" flare adapter
- Operating Pressure: 10" W.C.
- Supply Pressure: 11" to 14" W.C.

Side Burner Dimensions (Built-in)

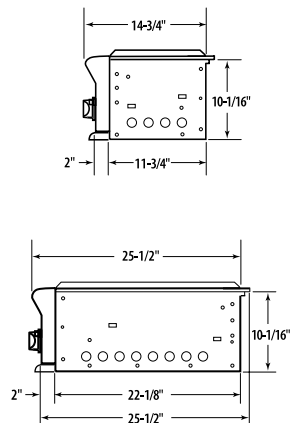

Side Burner Dimensions (30" Cart Mount)

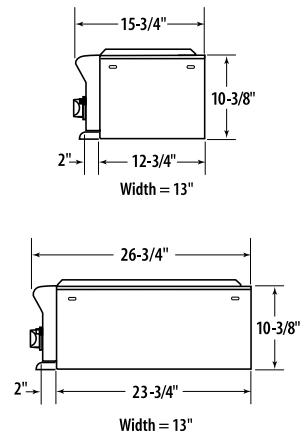

Professional Side Burner Island Preparation

MODEL	A
BGB131-BI	12"
BGB132-BI	22-3/8"

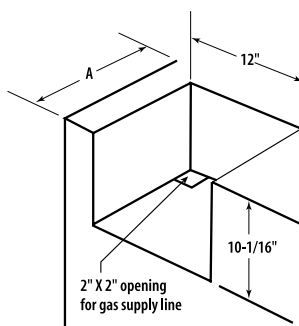

NOTE: Cart Mount Side Burners are not designed for built-in applications.

MODEL NUMBER	BGB131	BGB131-BI	BGB132	BGB132-BI
30" CART MOUNT	•		•	
BUILT-IN		•		•
SIDE BURNER(S)	1@17,000 BTU/HR	1@17,000 BTU/HR	2@17,000 BTU/HR	2@17,000 BTU/HR

Ordering Data: Please specify gas type (natural or propane) when ordering.

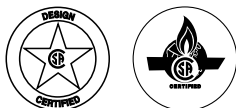

Because of continuing product improvement these specifications are subject to change without notice.



PERFECT HEAT.

For more information on our complete line of residential kitchen appliances or to find out more about our outdoor product line, please call 1.800.433.8466 or visit www.dcsappliances.com

©2004 DCS 5800 Skylab Road, Huntington Beach, CA 92647
Document revised 8/2004